

SONY®

TRINITRON® COLOR VIDEO MONITOR

BVM-1410P

BVM-1410PM

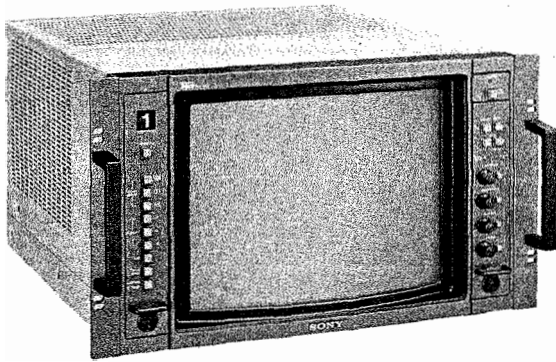

OPERATION AND MAINTENANCE MANUAL

4th Edition

Serial No. 2001066 and Higher (BVM-1410P)

(EBU N-10 LEVEL)

Serial No. 2000021 and Higher (BVM-1410PM)

Warning—This equipment generates, uses, and can radiate radio frequency energy and if not installed and used in accordance with the instructions manual, may cause interference to radio communications. It has been tested and found to comply with the limits for a Class A computing device pursuant to Subpart J of Part 15 of FCC Rules, which are designed to provide reasonable protection against such interference when operated in a commercial environment. Operation of this equipment in a residential area is likely to cause interference in which case the user at his own expense will be required to take whatever measures may be required to correct the interference.

Important—To insure that the complete system (including this peripheral) is capable of complying with the FCC requirements, it is recommended that the user make sure that the individual equipment of the complete system has a label with one of the following statements.

"This equipment has been tested with a Class A Computing Device and has been found to comply with Part 15 of FCC rules."

—or—

"This equipment complies with the requirements in Part 15 of FCC rules for a Class A Computing Device."

—or equivalent.

For the customers in Canada

This apparatus complies with the Class A limits for radio noise emissions set out in Radio Interference Regulations.

Pour les utilisateurs au Canada

Cet appareil est conforme aux normes Classe A pour bruits radioélectriques, spécifiés dans le Règlement sur le brouillage radioélectrique.

SAFETY-RELATED COMPONENT WARNING!!

COMPONENTS IDENTIFIED BY SHADING AND MARK  ON THE SCHEMATIC DIAGRAMS, EXPLODED VIEWS AND IN THE PARTS LIST ARE CRITICAL TO SAFE OPERATION. REPLACE THESE COMPONENTS WITH SONY PARTS WHOSE PART NUMBERS APPEAR AS SHOWN IN THIS MANUAL OR IN SUPPLEMENTS PUBLISHED BY SONY. CIRCUIT ADJUSTMENTS THAT ARE CRITICAL TO SAFE OPERATION ARE IDENTIFIED IN THIS MANUAL. FOLLOW THESE PROCEDURES WHENEVER CRITICAL COMPONENTS ARE REPLACED OR IMPROPER OPERATION IS SUSPECTED.

VORSICHT!!

Hinweis für den Benutzer

Das Gerät ist nicht für den Einsatz in Bildschirmarbeitsplätzen, vorgesehen.

CAUTION!!

DO NOT USE THE EXTERNAL DEGAUSSER TO DEMAGNETIZE THE SCREEN.
BE SURE TO USE THE DEGAUSS SWITCH ON THE FRONT PANEL.

CONFIDENTIAL

The material contained in this manual consists of information that is the property of Sony Corporation and is intended solely for use by the purchasers of the equipment described in this manual.

Sony Corporation expressly prohibits the duplication of any portion of this manual or the use thereof for any purpose other than the operation or maintenance of the equipment described in this manual without the express written permission of Sony Corporation.

CONFIDENTIEL

Le matériel contenu dans ce manuel consiste en informations qui sont la propriété de Sony Corporation et sont destinées exclusivement à l'usage des acquéreurs de l'équipement décrit dans ce manuel.

Sony Corporation interdit formellement la copie de quelque partie que ce soit de ce manuel ou son emploi pour tout autre but que des opérations ou entretiens de l'équipement à moins d'une permission écrite de Sony Corporation.

VERTRAULICH

Das in dieser Anleitung enthaltene Material besteht aus Informationen, die Eigentum der Sony Corporation sind, und ausschließlich zum Gebrauch durch den Käufer der in dieser Anleitung beschriebenen Ausrüstung bestimmt sind.

Die Sony Corporation untersagt ausdrücklich die Vervielfältigung jeglicher Teile dieser Anleitung oder den Gebrauch derselben für irgendeinen anderen Zweck als die Bedienung oder Wartung der in dieser Anleitung beschriebenen Ausrüstung ohne ausdrückliche schriftliche Erlaubnis der Sony Corporation.

ATTENTION AU COMPOSANT AYANT RAPPORT A LA SÉCURITÉ!!

LES COMPOSANTS IDENTIFIÉS PAR UN TRAMÉ ET UNE MARQUE  SUR LES DIAGRAMMES SCHEMATIQUES, LES VUES EXPLOSÉES ET LA LISTE DES PIÈCES SONT CRITIQUES POUR LA SÉCURITÉ DE FONCTIONNEMENT. NE REMPLACER CES COMPOSANTS QUE PAR DES PIÈCES SONY DONT LES NUMÉROS SONT DONNÉS DANS CE MANUEL OU DES SUPPLÉMENTS PUBLIÉS PAR SONY. LES RÉGLAGES DU CIRCUIT QUI SONT CRITIQUES POUR LA SÉCURITÉ DE FONCTIONNEMENT SONT IDENTIFIÉS DANS CE MANUEL. SUIVRE LES PROCÉDURES QUAND LES COMPOSANTS CRITIQUES SONT REMPLACÉS OU LE FONCTIONNEMENT IMPROPRE EST SUSPECTÉ.

ATTENTION!!

NE PAS UTILISER DE DÉMAGNÉTISEUR EXTÉRIEUR POUR DÉMAGNÉTISER L'ÉCRAN.
UTILISER LA TOUCH DE DÉMAGNÉTISATION (DEGAUSS) SUR LE PANNEAU FRONTAL.

TABLE OF CONTENTS

1. OPERATION

1-1.	Outline	1-1
1-1-1.	Features	1-1
1-1-2.	Options	1-2
1-2.	Voltage selection	1-3
1-3.	Location and function of controls	1-4
1-3-1.	Front panel	1-4
1-3-2.	Rear panel	1-6
1-3-3.	Sub control panels inside the drawers	1-8
1-3-4.	Switches inside the cabinet	1-12
1-4.	Convergence adjustment	1-13
1-5.	White balance adjustment	1-14
1-6.	Specifications	1-14
1-7.	Packing	1-16

2. DISASSEMBLY

2-1.	Cabinet Removal and the Side Panels	2-1
2-2.	Bezel Assembly Removal	2-1
2-3.	Bottom Cover Removal	2-2
2-4.	Check of C Board	2-2
2-5.	BK Block Removal	2-3
2-6.	Check of BK Board	2-3
2-7.	Check of BJ Board	2-4
2-8.	GC Board Removal	2-4
2-9.	QA, W and V Boards Removal	2-5
2-10.	Flyback Transformer and High Voltage Block Removal	2-5
2-11.	Picture Tube Removal	2-6
2-12.	Checking of PA Board	2-6
2-13.	Power Block Assembly Removal	2-7

3. CIRCUIT DESCRIPTIONS

3-1.	QA, QB, BA Boards	3-1
3-2.	BG Board	3-3
3-3.	BH Board	3-5
3-4.	BI Board	3-7
3-5.	Sync Processor, Pulse Generator (BJ Board)	3-9
3-6.	BK Board	3-13
3-7.	Beam Control Circuit (BI, BK Boards)	3-15
3-8.	PAL Demodulator, Y Trap Circuit (BD Board)	3-17
3-9.	PAL-M Demodulator, Y Trap Circuit (BM Board)	3-19
3-10.	Vertical Deflection Output Circuit Convergence Output Circuit (EB Board)	3-21
3-11.	Power Supply Circuit (GA, GB Boards)	3-23
3-12.	Convergence Circuit (DB, EB Boards, Hct Block)	3-25
3-13.	Deflection Circuit (DA Board)	3-29
3-14.	Horizontal Output (EA Board)	3-33
3-15.	High Voltage Regulator (PA Board)	3-35

4. ADJUSTMENTS

4-1.	Internal View	4-1
4-2.	Circuit Boards Location	4-2
4-3.	Quick Reference	4-3
4-4.	Sub Control Panel Location	4-4
4-5.	Setup Adjustment in Case of Picture Tube Replacement	4-5
4-6.	Safety Related Adjustments	4-11
4-7.	Circuit Adjustments	4-17

5. DIAGRAMS

5-1.	Block Diagram	5-1
5-2.	Frame Wiring Diagram	5-3
5-3.	Mounting and Schematic Diagrams	5-5
	BA Board	5-7
	BD or BM Board	5-12
	BG Board	5-17
	BH Board	5-22
	BI Board	5-27
	BJ Board	5-32
	BK Board	5-37
	DA Board	5-42
	DB Board	5-47
	EA and EB Boards	5-52
	GA and GB Boards	5-58
	C, PA and PB Boards	5-64
	HA, HB, HC, HD, HG, HH, XB, and Y Boards	5-69
	GC, QA, QB, V and W Boards	5-73
	TA Board	5-77
	TB Board	5-81
	Z Board	5-85
5-4.	Semiconductors	5-87

6. EXPLODED VIEWS

6-1.	Bezel	6-1
6-2.	Picture Tube	6-2
6-3.	Chassis	6-3
6-4.	Signal Block	6-4
6-5.	Drawer Block (Right)	6-5
6-6.	Drawer Block (Left)	6-6
6-7.	Power Block	6-7

7. ELECTRICAL PARTS LIST..... 7-1

SECTION 1 OPERATION

1-1. OUTLINE

1-1-1. Features

The BVM-1410P/PM is a color video monitor designed for critical evaluation of video signals in broadcasting stations and production houses.

High resolution picture

The Super Fine Pitch Trinitron picture tube (0.25 mm aperture grille) gives a high resolution, high contrast picture. Horizontal resolution is more than 700 TV lines at the center of the picture.

Stabilized color temperature

The newly-developed beam control circuit maintains the color temperature constant for a long period of time.

Split screen for precise picture confirmation

The lower half of the picture can be displayed in monochrome mode while the upper half is displayed in color mode. This facilitates confirmation of the luminance and chrominance channels, evaluation of the noise in chrominance or luminance channel, etc.

Blue only mode for precise evaluation of noise component

In blue only mode, an apparent monochrome display is obtained with all three control grids driven with a blue signal. This facilitates color saturation and phase adjustments and observation of VTR noise.

Easy and precise convergence adjustment

The convergence can be adjusted at 15 points of the screen. This system facilitates adjustment of the peripheral areas of the screen.

Other features

- Three color standards selectable using the optional plug-in type decoder boards
- Picture set-up function facilitating adjustment of the monitor reference black for the black level of an incoming video signal
- Pulse cross function for simultaneous checking of the horizontal and vertical sync signals or VITS (Vertical Interval Test Signal)
- Built-in crosshatch and 100% white signal generators facilitating monitor set-up
- VITC (Vertical Interval Time Code) display possible using the optional VITC reader board
- Two pull-out drawers containing convergence, white balance and preset controls, and other function selectors
- Auto and manual degaussing
- Three-position AFC switch
- Overdrive protection circuit to protect against picture tube damage
- EIA standard 19-inch rack mounting possible using the optional rack mount kit

1-1-2. Options

Model No.	Product name	Board name	Use
BKM-1410	NTSC ADAPTOR	BC	Decoder board for NTSC color system
BKM-1411	NTSC COMB ADAPTOR	BB	Comb filter board for NTSC color system
BKM-1412	NTSC COMB ADAPTOR	BT	Dynamic Comb filter board for NTSC color system
BKM-1420	PAL ADAPTOR	BD	Decoder board for PAL color system
BKM-1421	PAL-M ADAPTOR	BM	Decoder board for PAL-M color system
BKM-1422	PAL COMB ADAPTOR	BT	Comb filter board for PAL color system
BKM-1430	SECAM ADAPTOR	BE	Decoder board for SECAM color system
BKM-1440	RGB/COMPONENT ADAPTOR	BF	Decoder outputs of RGB or component signals
BKM-1460	VITC ADAPTOR	BL	Reader of Vertical Interval Time Code
BKM-1470	SAFE AREA DISPLAY	BQ	For displaying the safe area
BKM-1480	BLACK LEVEL SIGNAL GENERATOR	BS	For generating black level signals
BKM-1450	AUTO SET-UP ADAPTOR	BN BO	Auto chroma/phase adjustment, auto white balance adjustment, selection of color temperature
BKM-2085 -14	DIGITAL 4:2:2 SERIAL INPUT KIT	BA3 BV	For input of the component digital video signal
BKM-2090 -14	D-2 SERIAL INPUT KIT	BA3 BU	For input of the composite digital video signal
BKM-1400	RACK MOUNT KIT	—	For EIA standard 19 inch rack mounting

Combinations of the optional boards

The BVM-1410P is supplied with the BD circuit board (PAL color system decoder), while the BVM-1410PM is supplied with the BM circuit board (PAL-M color system decoder).

You can choose up to five optional B boards above including BD or BM. The combinations of the B boards are limited depending on which boards can be accepted for each board compartment.

You can choose up to five optional B boards above

Board name (Function)	Compartment name				
	B5	B4	B3	B2	B1
BB (NTSC COMB FILTER)	X	O	O	O	O
BT (NTSC COMB FILTER)	O	O	O	O	O
BT (PAL COMB FILTER)	O	O	O	O	O
BC (NTSC DECODER)	O	O	O	O	O
BD (PAL DECODER)	O	O	O	O	O
BE (SECAM DECODER)	O	O	O	O	O
BM (PAL-M DECODER)	O	O	O	O	O
BF (RGB/COMPONENT)	X	X	O	X	X
BL (VITC)	X	X	X	O	X
BQ (SAFE AREA DISPLAY)	X	△	X	O	X
BS (BLACK LEVEL SIGNAL GENERATOR)	O	O	O	O	O
BN (AUTO SET-UP BO ADAPTOR)	O	O	X	X	X
BV (Digital 4:2:2 serial interface)	X	X	X	X	O
BU (D-2 serial interface)	X	X	X	X	O

O: acceptable

X: not acceptable

△: acceptable but the switch or control settings on the sub control panels cannot control the display.

1-2. VOLTAGE SELECTION

Notes

- Insert BA, BG, BH, BI and BJ boards into their respective compartments of the same name.
- Do not leave B5 compartment blank. Insert one of the boards specified in the above table. If no board is inserted, the luminance/chrominance or luminance channel will not be activated in composite signal mode.
- Do not insert BD (PAL DECODER) and BM (PAL-M DECODER) boards simultaneously. This causes malfunction of the monitor.
- Do not insert BB (NTSC COMB FILTER) and BT (NTSC COMB FILTER) boards simultaneously. This causes malfunction of the monitor.

For details on installation, refer to the operation and maintenance manual of the optional board.

The monitor operates on either 220 – 240 or 100 – 120V AC. Before connecting the unit to an AC outlet, make sure the voltage selector at the rear of the unit is set to the local power line voltage. Change the position of the selector if necessary.

The factory preset operating voltage of each model is as follows.

BVM-1315, 1415PM	100—120V
BVM-1415P	220—240V

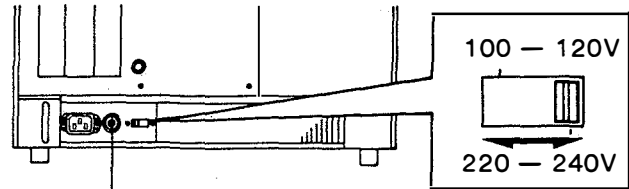

Fuse holder

Right view (with the cabinet removed)

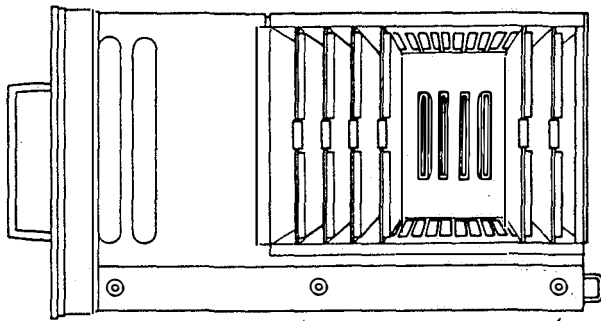

Board compartments

Note

Use a T2A/250V fuse for 220 – 240V AC operation, and a 4A/125V fuse for 100 – 120V AC operation. The appropriate fuse is installed at the factory in accordance with the voltage presetting. If you change the voltage selector setting, replace the fuse with an appropriate one.

1-3. LOCATION AND FUNCTION OF CONTROLS

1-3-1. Front Panel

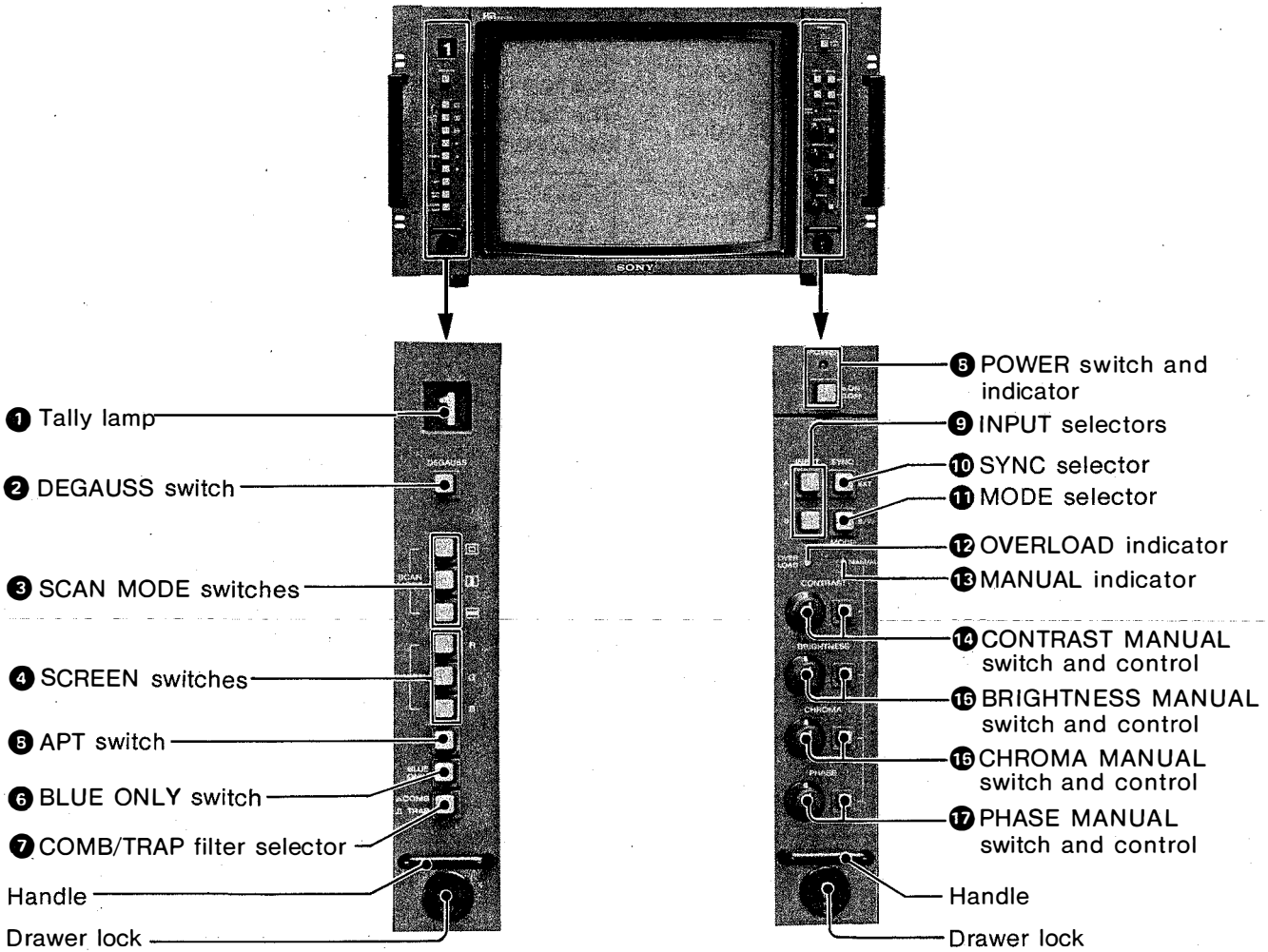

1 Tally lamp

Insert one of the tally number plates 1 to 5 (supplied) when the drawer is open. The lamp lights when No. 3 and No.8 pins of the REMOTE connector on the rear panel are short-circuited.

2 DEGAUSS switch

When the power is turned on, automatic degaussing is activated. To demagnetize the screen manually, press this switch momentarily with the power turned on. Wait for 5 minutes or more before activating degaussing again.

3 SCAN MODE switches

- (underscan): Depress this switch for under-scanning. The display size is reduced by approximately 3% so that four corners of the raster are visible.
- (horizontal delay): Depress this switch to observe the horizontal sync signal. The picture is shifted horizontally and the horizontal sync signal is displayed in the left quarter of the screen. Picture brightness is automatically increased for easy observation.
- (vertical delay): Depress this switch to observe the vertical sync signal. The picture is shifted vertically and the vertical sync signal is displayed near the center of the screen. Picture brightness is automatically increased for easy observation.
- A pulse cross is displayed by depressing both the and switches.
- To resume normal scanning, press to release the depressed switches.

4 SCREEN switches

The R, G and B switches turn the red, green and blue beams respectively on and off. To turn off the beam, depress the switch. To turn it on again, press to release it.

5 APT (aperture) switch

Normally keep this switch released. A flat frequency response is obtained.

For aperture correction, depress this switch and adjust the APT control **22**. The boost frequency, 4.5 MHz or 6.5 MHz, can be selected with the S1 switch on the BG board.

At the 4.5 MHz position, the frequency response can be adjusted continuously with up to 6 dB boost at 4.5 MHz for subjective enhancement of the displayed picture.

At the 6.5 MHz position, the frequency response can be adjusted continuously with up to 6 dB boost at 6.5 MHz for compensation of the aperture loss of the CRT.

6 BLUE ONLY switch

Normally keep this switch released. Depress this switch to turn off the red and green signals. A blue signal is displayed as an apparent monochrome picture on the screen. This facilitates CHROMA and PHASE control adjustments and observation of VTR noise.

7 COMB/TRAP filter selector

This selector is effective for the NTSC color system only, with the BKM-1410 NTSC adaptor and the BKM-1411 or BKM-1412, NTSC comb adaptor installed.

Depress the selector to activate the comb filter (\square COMB). Press to release it for the trap filter (\square TRAP).

When the BKM-1411 or BKM-1412, NTSC comb adaptor is not installed, or when a color system other than NTSC is selected, the trap filter is always activated regardless of this selector setting.

8 POWER switch and indicator

Depress this switch to turn on the power. The POWER indicator will light. To turn the power off, press the switch again.

9 INPUT selectors

Select the input signal.

A: To monitor the signals connected to the VIDEO A INPUT connector, depress this selector.

B: To monitor the signals connected to the VIDEO B INPUT connector, depress this selector and press the INPUT SELECT "B" button inside the right drawer.

For details on input selection, refer to "INPUT SELECT buttons" on page 1-11.

10 SYNC selector

Normally keep this selector released (INT). The monitor operates on the sync signal from the displayed composite video signal. To operate the monitor on an external sync signal supplied from the EXT SYNC connector on the rear panel, depress the selector (EXT).

11 MODE selector

Normally keep this selector released (AUTO). Color or monochrome mode is automatically selected according to the presence or absence of color burst. Depress the selector (MONO) to display the monochrome picture.

12 OVERLOAD indicator

This indicator lights to warn of overdrive of the CRT.

13 MANUAL indicator

This indicator lights when any of the MANUAL switches **14** through **17** is depressed.

14 CONTRAST MANUAL switch and control

When this switch is in the released position, the contrast preset with the PRESET CONTRAST control inside the right drawer is obtained. To adjust the contrast manually, depress this switch and turn this control.

15 BRIGHTNESS MANUAL switch and control

When this switch is in the released position, the brightness preset with the PRESET BRIGHTNESS control inside the right drawer is obtained. To adjust the brightness manually, depress this switch and turn this control.

16 CHROMA MANUAL switch and control

When this switch is in the released position, the color saturation preset with the PRESET CHROMA control inside the right drawer is obtained. To adjust the color saturation manually, depress this switch and turn this control.

17 PHASE MANUAL switch and control

When this switch is in the released position, the subcarrier phase preset with the PRESET PHASE control inside the right drawer is obtained. To adjust the subcarrier phase manually, depress this switch and turn this control.

(This control is not effective when the COLOR STANDARD PAL button is pressed and the PAL D/S selector is set to D, or when the COLOR STANDARD SECAM button is pressed.)

1-3-2. Rear Panel

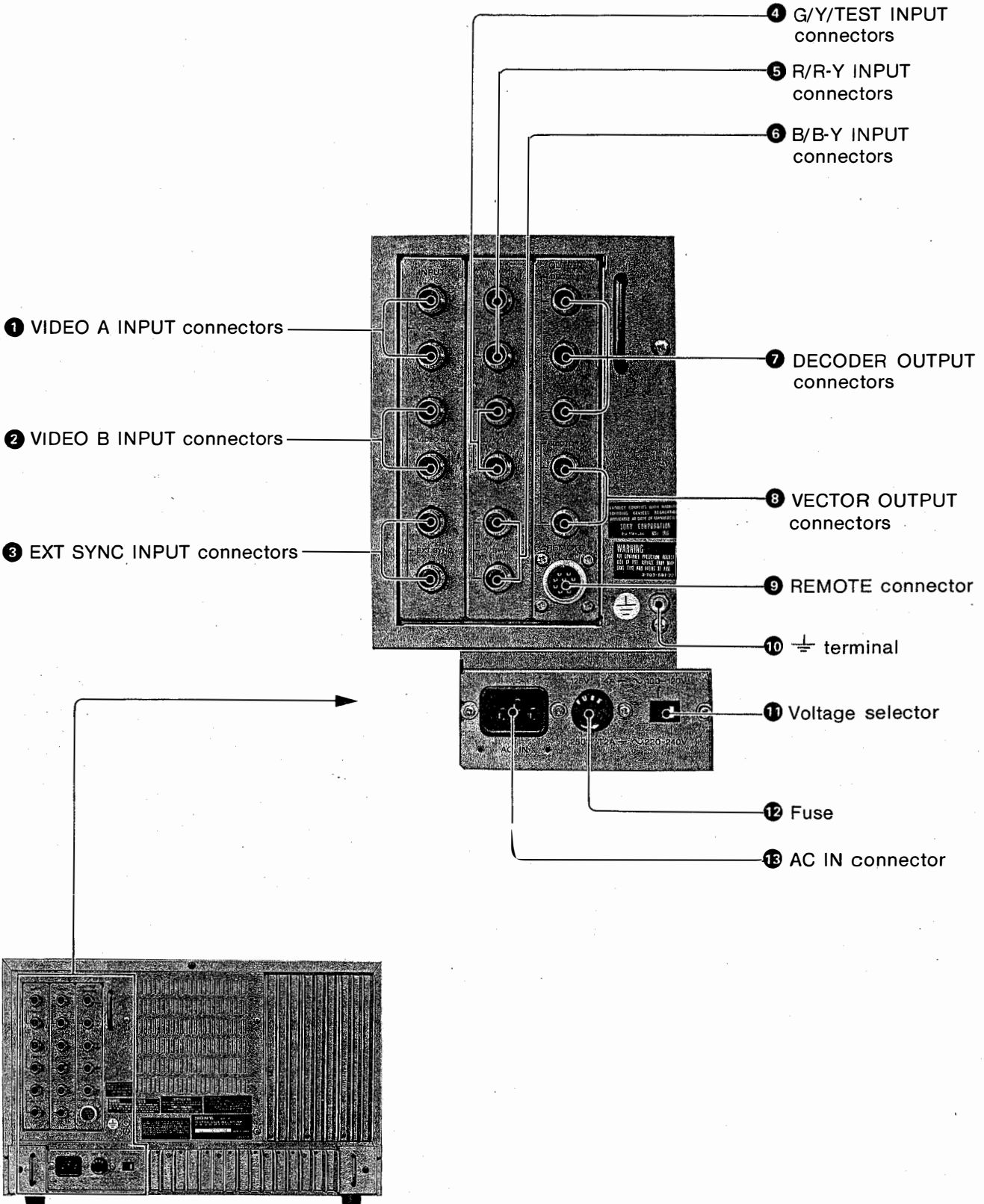

1 VIDEO A INPUT connectors (BNC)

2 VIDEO B INPUT connectors (BNC)

Accept video signals. Use one connector for input and the other for loop-through output.

When the loop-through output is not used, attach a 75-ohm terminator.

3 EXT SYNC INPUT (external sync input) connectors (BNC)

Accept sync signals.

Use one connector for input and the other for loop-through output.

When the loop-through output is not used, attach a 75-ohm terminator.

4 G/Y/TEST INPUT connectors (BNC)

5 R/R-Y INPUT connectors (BNC)

6 B/B-Y INPUT connectors (BNC)

Input an RGB, component (Y, R-Y, B-Y) or test signal. The input signal can be selected with the INPUT SELECT buttons on the sub control panel. Use one connector for input and the other for loop-through output. When the loop-through output is not used, attach a 75-ohm terminator.

7 DECODER OUTPUT connectors (BNC)

These connectors provide RGB or component (Y, R-Y, B-Y) outputs decoded from the signals displayed on the screen, only when the BKM-1440 RGB/component adaptor is installed.

The RGB or component outputs are selected with the S1 selector on the BF board of the BKM-1440 kit.

Quick reference for output selection

Output signal Operation	Component	RGB
S1 selector on BF board	Lower position	Upper position
Input signal	Encoded VIDEO A, VIDEO B, TEST or component	
Output connectors	DECODER OUTPUT (R/R-Y, G/Y, B/B-Y)	

Notes

- The DECODER OUTPUT connectors do not provide the correct RGB outputs from the displayed RGB signals. For RGB outputs, use the loop-through outputs of the R/G/B input connectors.
- The outputs from non-composite signals are also non-composite. Supply sync signals from the EXT SYNC INPUT connector if required.
- The output signals are affected by the CHROMA, PHASE and APERTURE controls and MATRIX switch.
- The color killer is not activated for output signals.

8 VECTOR OUTPUT connectors (BNC)

Provide R-Y and B-Y demodulated chroma outputs. Connect the Tektronix 1424 display unit or equivalent to provide vector displays. Connect the R-Y connector to the Y input of the display unit, and the B-Y connector to the X input.

9 REMOTE connector (10-pin)

Use the supplied 10-pin connector.

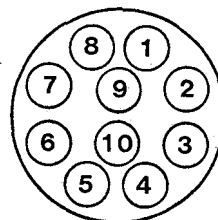

To enter remote control mode, short-circuit pin No. 5 with pin No. 8.

The relationship between the function and pin connections in remote control mode are shown below.

Function			Pin No.						
INPUT*	SYNC*	MODE*	1	2	3	4	5	6	7
VIDEO A	INT	AUTO	O	O	—	O	S	—	—
		MONO	S	O	—	O	S	—	—
	EXT	AUTO	O	O	—	S	S	—	—
		MONO	S	O	—	S	S	—	—
VIDEO B	INT	AUTO	O	S	—	O	S	—	—
		MONO	S	S	—	O	S	—	—
	EXT	AUTO	O	S	—	S	S	—	—
		MONO	S	S	—	S	S	—	—
VITC OFF**			—	—	—	—	—	S	—
VITC HOLD**			—	—	—	—	—	O	S
TALLY ON			—	—	S	—	—	—	—

S: Short-circuit with pin No. 8.

O: Open

—: Either S or O.

* Remote control operations have priority over the MODE, INPUT and SYNC selectors on the front panel.

** To remotely control the VITC display, first set the VITC switch inside the right drawer to ON and then short-circuit pin 6 or 7 with pin 8. (For VITC display, the optional BKM-1460 is required.)

Note

For remote control operations, be sure to depress the INPUT SELECT "B" button inside the right drawer.

10 Ground (⊥) terminal

Connect to the system ground, if necessary.

11 Voltage selector

Set to the local power line voltage, 220 – 240V AC or 100 – 120V AC.

12 Fuse

Use a T2A fuse for operation on 220 – 240V AC, or a 4A fuse for operation on 100 – 120V AC.

13 AC IN connector

Connect the supplied AC power cord here and secure it with the supplied cord stopper, if required.

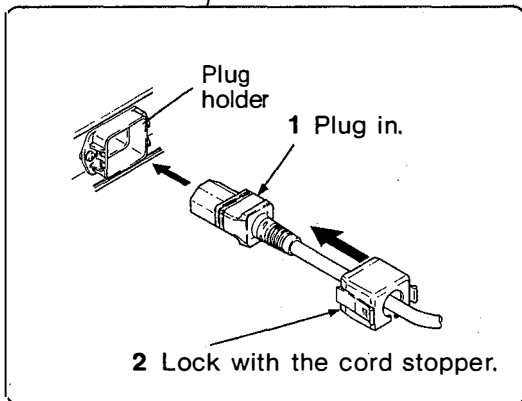
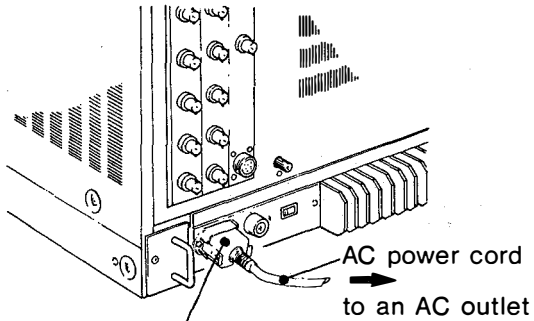

1-3-3. Sub Control Panels inside the Drawers

Insert the supplied key into the keyhole of the drawer lock, turn it 90° clockwise and pull the drawer out.

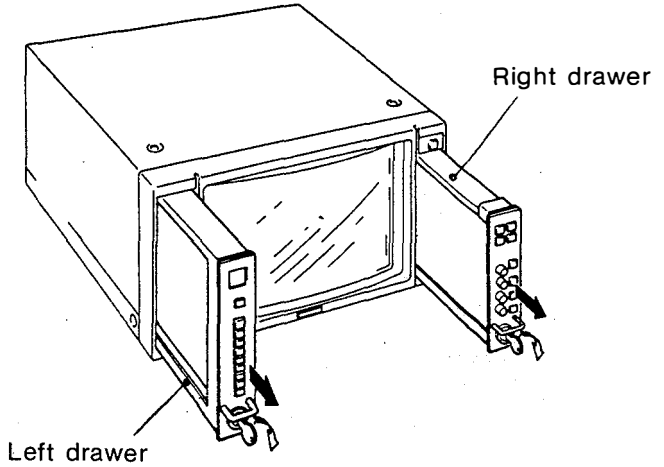

- Adjust the controls on the sub control panels when the monitor is fully warmed up. Warm-up time will be at least 30 minutes after the power has been turned on.
- Adjust the control using the supplied screwdriver.

Inside the right drawer

HB board (Function selection and white balance adjustment section)

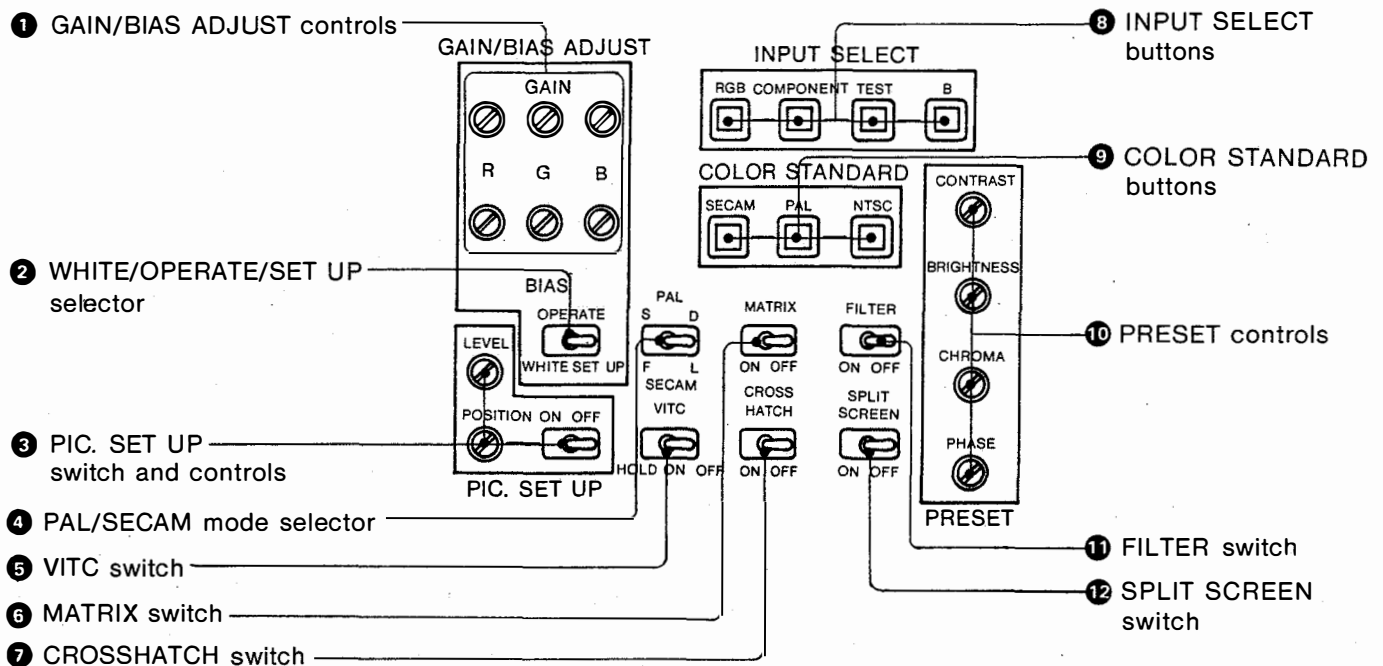

1 GAIN/BIAS ADJUST controls

Used for white balance adjustment.

GAIN and BIAS controls are provided for the R (red), G (green) and B (blue) screens.

BIAS: Set the WHITE/OPERATE/SET UP selector to SET UP and adjust the white balance and brightness of the screen at the lowlight with these controls.

GAIN: Set the WHITE/OPERATE/SET UP selector to WHITE and adjust the white balance and contrast of the screen at the highlight with these controls. For details on the white balance adjustment, refer to "1-5. WHITE BALANCE ADJUSTMENT" on page 1-15.

2 WHITE/OPERATE/SET UP selector

OPERATE: Normally set to this position for normal monitoring.

WHITE: When adjusting the white balance at the highlight, set to this position. Internal 100% white signal is displayed on the screen.

SET UP: When adjusting the white balance at the lowlight, set to this position. A horizontal white bar of approximately 1/3 the screen height is displayed.

3 PIC. SET UP (picture set up) switch and controls

Used to match the black reference of the monitor with the black level of the input signal.

ON/OFF switch: When this switch is set to ON, a vertical picture band and the black reference of the monitor are displayed on the screen for easy level comparison.

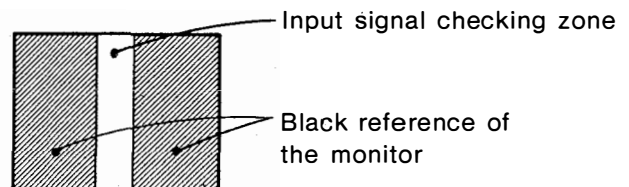

POSITION control: Move the position of the picture band horizontally so that the black signal of the picture is located next to the black reference area.

LEVEL control: Adjust this control to match the brightness of the black reference area with that of the input black signal.

4 PAL/SECAM mode selector

This selector functions as the PAL D/S selector for PAL color system, and as the SECAM F/L selector for SECAM color system.

PAL D/S selector: Selects the demodulation mode of the PAL system, D (deluxe) or S (simple). Normally set to D.

SECAM F/L selector: Selects the ID signal of the SECAM system, L (line) or F (field). Normally set to L.

5 VITC (Vertical Interval Time Code) switch

This switch functions only when the optional BKM-1460 VITC adaptor is installed.

ON: Set to this position to display the VITC.

OFF: To turn off the VITC display.

HOLD: To hold the VITC figure, press the switch momentarily to this position. To run the VITC again, press the switch to this position again.

6 MATRIX switch

Normally set this switch to OFF. Set to ON to activate the matrix circuit so that the chromaticity of the displayed picture more closely approximates to that of "true" NTSC phosphors.

7 CROSSHATCH switch

Set to ON to display the internal crosshatch pattern for adjusting convergence, etc.

The crosshatch pattern is synchronized to the selected composite sync signal.

8 INPUT SELECT buttons

To monitor one of the following four input signals, depress the INPUT B selector on the front panel and press the appropriate button.

RGB: To monitor the R/G/B signals connected to the R/R-Y, G/Y/TEST and B/B-Y connectors

COMPONENT: To monitor the component (R-Y, Y and B-Y) signals connected to the R/R-Y, G/Y/TEST and B/B-Y connectors

TEST: To monitor the composite video signals connected to the G/Y/TEST connector

B: To monitor the composite video signals connected to the VIDEO B INPUT connector

Quick reference for input selection

Input signal Operation	Encoded video			Component	RGB
	VIDEO A	VIDEO B	TEST		
INPUT selectors (front panel)	A	B	B	B	B
INPUT SELECT buttons (right drawer)		B	TEST	COMPONENT	RGB
INPUT connectors	VIDEO A	VIDEO B	G/Y/TEST	R/R-Y, G/Y/TEST, B/B-Y	R/R-Y, G/Y/TEST, B/B-Y

9 COLOR STANDARD buttons

Select the color standard of the input picture.

For displaying the picture of each color standard, the appropriate decoder board (optional) should be installed. See page 1-2.

SECAM: For SECAM standard

PAL: For PAL or PAL-M standard

NTSC: For NTSC standard

Note

If the decoder board for the selected color system is not installed:

- The picture does not appear on the screen when the FILTER switch 11 is set to ON.
- The picture is displayed in monochrome mode when the FILTER switch is set to OFF.

10 PRESET controls

Adjust the preset levels.

CONTRAST: Preset the picture contrast level.

BRIGHTNESS: Preset the picture brightness level.

CHROMA: Preset the color saturation level.

PHASE: Preset the subcarrier phase.

11 FILTER switch

This switch functions only when the MODE selector on the front panel is set to MONO.

Normally set to ON to activate the comb or trap filter. Set to OFF to deactivate the filter for a wider frequency range.

- When the MODE selector is set to AUTO, the filter is always activated for color signals regardless of this switch setting.

12 SPLIT SCREEN switch

Normally set to OFF. When this switch is set to ON, the lower half of the picture is displayed in monochrome mode.

Inside the left drawer

DB board (Convergence adjustment section)

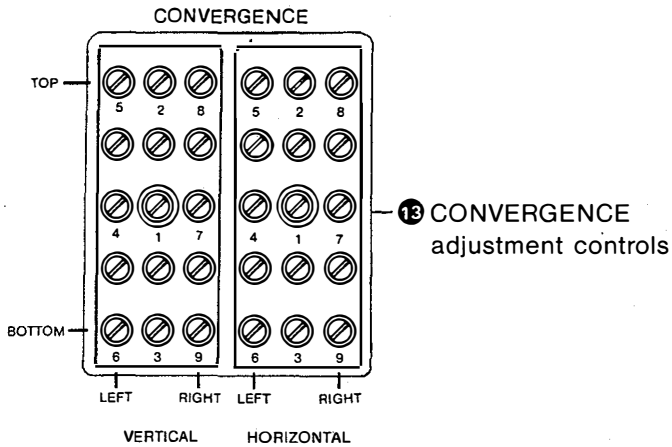

13 CONVERGENCE adjustment controls

Used to adjust the convergence of the picture. The VERTICAL controls adjust the convergence vertically; the HORIZONTAL controls adjust it horizontally. 15 controls cover the entire screen so that each control adjusts the corresponding portion of the screen. Refer to "1-4. CONVERGENCE ADJUSTMENT" on page 1-14.

DA board (H.V. oscillator section)

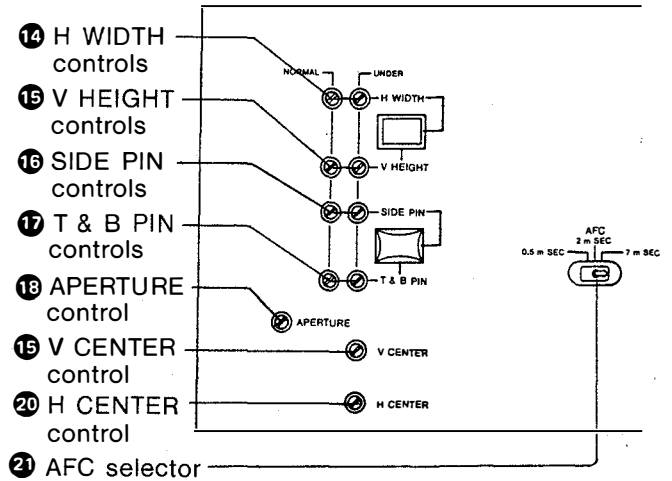

14 H WIDTH (horizontal width) controls

Adjust the width of the picture. Use the NORMAL control for the normal picture, and the UNDER control for the underscanned picture.

15 V HEIGHT (vertical height) controls

Adjust the height of the picture. Use the NORMAL control for the normal picture, and the UNDER control for the underscanned picture.

16 SIDE PIN (pincushion) controls

Correct the side pincushion distortion. Use the NORMAL control for the normal picture, and the UNDER control for the underscanned picture.

17 T & B PIN (top and bottom pincushion) distortion

Correct the top and bottom pincushion distortion. Use the NORMAL control for the normal picture, and the UNDER control for the underscanned picture.

18 APERTURE control

Adjusts the frequency response when the APT switch on the front panel is depressed.

15 V CENTER (vertical centering) control

Adjusts the vertical position of the picture.

20 H CENTER (horizontal centering) control

Adjusts the horizontal position of the picture.

21 AFC (automatic frequency control) selector

Selects the AFC time constant.
0.5 mSEC (fast): This mode is fast enough to correct for VTR jitter. Set to this position to obtain a stable playback picture from a VTR.
2 mSEC (normal): Normally set to this position.
7 mSEC (slow): This mode is slow enough to display the time base instability introduced by mechanical jitter, in the VTR playback signal.

1-3-4. Switches inside the Cabinet

Remove the cabinet, referring to Section 2.

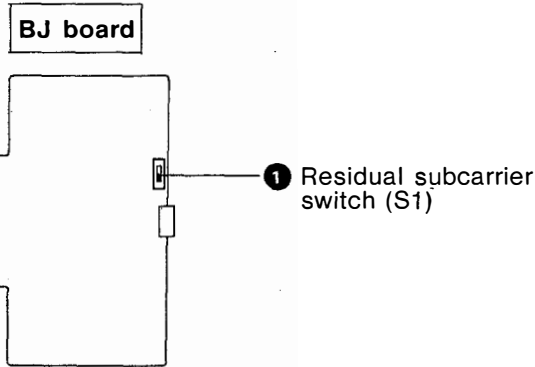

1 Residual subcarrier switch (S1)
 This switch is factory-preset to the lower position (OFF).
 Normally there will be no residual subcarrier in input video signals. However, if a residual subcarrier is present, this may affect the display.
 Set this switch to the upper position (ON) to check if a residual subcarrier is present. If it is present in the incoming signal, color shift appears in the picture.

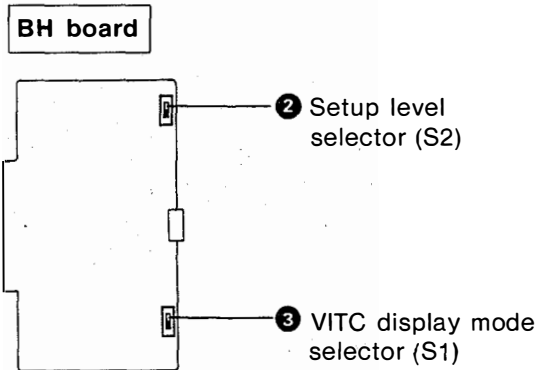

2 Setup level selector (S2)
 Select the setup level.
0 IRE: Setup level is 0%.
AUTO: Factory-preset position. Setup level is 0% when the field frequency of the input signal is 50 Hz, and 7.5% when the field frequency is 60 Hz.
7.5 IRE: Setup level is 7.5%.
 The setup level can be adjusted with the controls on the BH board: 0% level with the RV1 control, and 7.5% level with the RV2 control in the range from -2.5% through +12.5%.

3 VITC display mode selector (S1)
 Used to invert the character and background colors.
Upper position: Factory-preset position. The VITC is displayed in white characters with black background.
Lower position: The VITC is displayed in black characters with white background.
 For details, refer to the operation and maintenance manual of the BKM-1460 VITC adaptor.

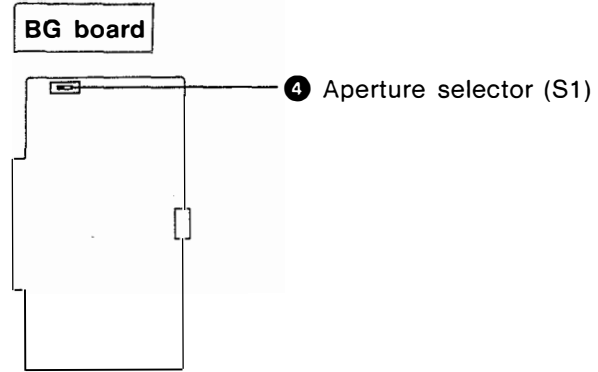

4 Aperture selector (S1)
 Selects the boost frequency, 4.5 MHz or 6.5 MHz, for aperture correction. This selector is factory-preset to 4.5 MHz.

QA and QB boards
 The QA and QB boards are located behind the INPUT connector panels.
 Remove the INPUT connector panels, referring to Section 2.

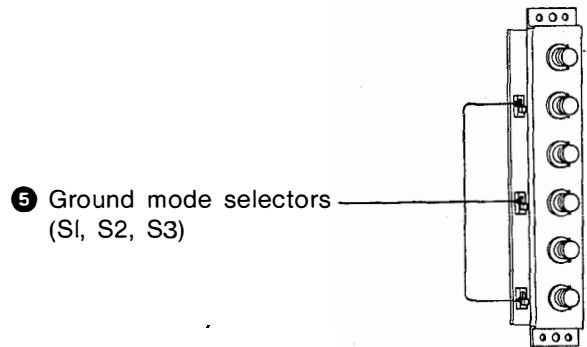

5 Ground mode selectors (S1, S2, S3)
 Three selectors are provided for each VIDEO A, VIDEO B and EXT SYNC connectors (QA board), or for each R/R-Y, G/Y/TEST and B/B-Y connectors (QB board).
S (non-floating): Factory-preset position. Normally keep the selectors at this position.
F (floating): When there is hum in the input signal, set to this position. Common mode noises will be rejected.

1-4. CONVERGENCE ADJUSTMENT

Use the CONVERGENCE controls inside the left drawer.

Adjust the convergence of corresponding portion of the screen as follows:

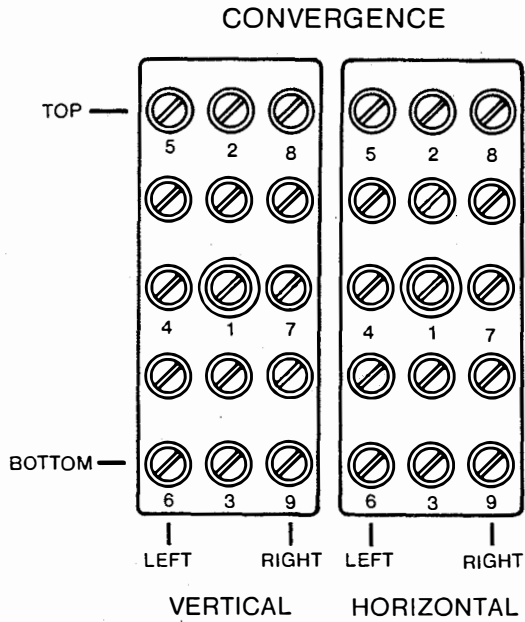

- Numbers 1 to 9 in the illustration above refer to the sequence of operations.
- The HORIZONTAL controls adjust the convergence horizontally, and the VERTICAL controls adjust the convergence vertically.
- When adjusting the convergence, observe the portion of the screen indicated by the ↓ or → mark in the illustrations. The red and blue beams move symmetrically to the green beam.

	VERTICAL	HORIZONTAL
1 At center		
2 At center top		
3 At center bottom		
4 At left center		
5 At top left		
6 At bottom left		
7 At right center		

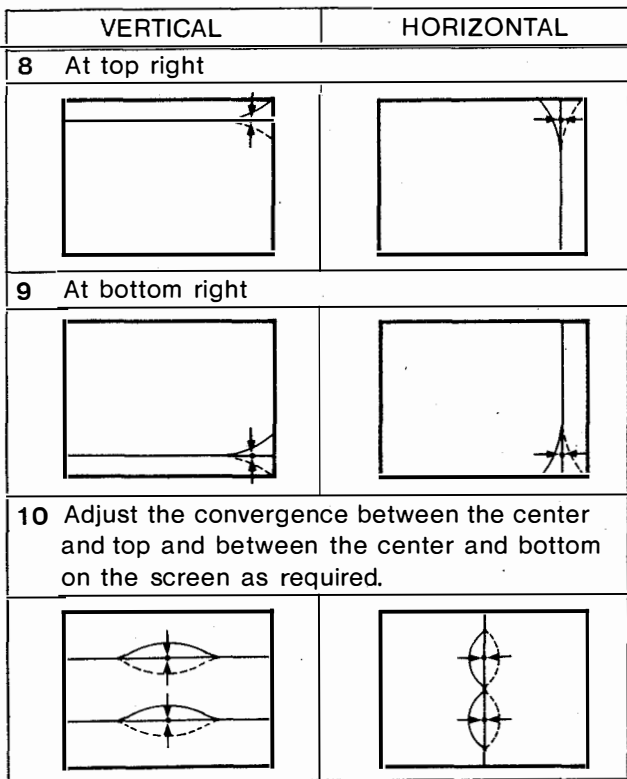

1-5. WHITE BALANCE ADJUSTMENT

Use the WHITE/OPERATE/SET UP selector and GAIN/BIAS ADJUST controls inside the right drawer. During adjustment, turn the red, green and blue beams on and off with the SCREEN switches on the front panel, as required.

GAIN/BIAS ADJUST

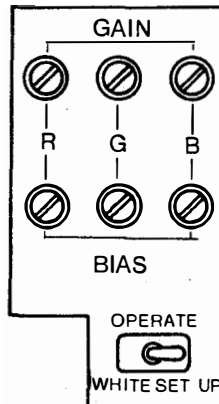

- 1 Display a test signal on the screen.
- 2 Set the WHITE/OPERATE/SET UP selector to SET UP.
- 3 Adjust the white balance at the lowlight with the BIAS controls.
- 4 Set the WHITE/OPERATE/SET UP selector to WHITE.
- 5 Adjust the white balance at the highlight with the GAIN controls.
- 6 After adjustment, set the WHITE/OPERATE/SET UP selector to OPERATE.

Note

For white balance adjustment using a color analyzer or equivalent, see Section 2.

1-6. SPECIFICATIONS

System	<p>BVM-1410P 625 lines per picture, 50 fields per second interlaced, PAL</p> <p>BVM-1410PM 525 lines per picture, 60 fields per second interlaced, PAL-M</p>	<p>Video signal Luminance channel (RGB and composite signals) Differential gain Within 2% for a luminance from 0 to 40 fL Differential phase Within 2° for a luminance from 0 to 40 fL</p> <p>Frequency response Monochrome mode: 100 Hz to 8 MHz ±1 dB (aperture correction at 0) Color mode: Trap filter removes frequency in 4.43 MHz region (BVM- 1410P) or 3.58 MHz region (BVM-1410PM).</p>
CRT	<p>Super Fine Pitch Trinitron 0.25 mm aperture grille, 90-degree deflection, φ36 mm in-line gun Effective picture size: 200.3 × 267.2 mm (h/w) (8 × 10⁵/₈ inches) 330.8 mm (13 inch) picture measured diagonally</p>	<p>Chrominance channel Demodulation axis R-Y, B-Y Bandpass 1.3 MHz equiband Subcarrier regeneration ±1 (standard input signal) Phase control range More than ±15 (standard input signal) Chroma gain control range More than ±6 dB</p>
Input		
Connectors	BNC type (12)	
Video	<p>VIDEO A/B, TEST, R/G/B 0.7 Vp-p, non-composite or 1 Vp-p, composite, video signal ±6 dB positive, high impedance, with loop- through output Y/R-Y/B-Y Y: Composite, 1.0 Vp-p ±6 dB, high impedance, loop-through R-Y/B-Y: 0.7 Vp-p±6 dB, high impedance, loop- through</p>	<p>Chrominance/luminance Time error Less than 30 nsec Gain error Less than 5% Aperture correction Adjustable continuously up to 6 dB boost at 4.5 MHz or 6.5 MHz (selectable)</p> <p>DC restoration (RGB and composite signals) Back porch type Back porch level: Within 1% of peak luminance, 10% to 90% APL (average picture level)</p>
Sync	<p>EXT SYNC 1 - 8 Vp-p negative, high impedance, with loop-through output</p>	
Return loss	More than 46 dB (7 MHz with 75-ohm termination)	
Hum rejection	<p>Reduced by more than 50 dB Maximum hum: Less than 4 Vrms, where hum is applied to the monitor in floating ground mode</p>	
Output		
Connectors	<p>VECTOR OUT: BNC type (2) DECODER OUT: BNC type (3) REMOTE: 10-pin connector (1)</p>	<p>Synchronization AFC time constant 0.5 msec: FAST 2 msec: NORMAL 7 msec: SLOW Line pull range/line hold range More than ±500 Hz at 0.5 msec time constant Vertical blanking time Normal: Within 1 msec. Underscan: Within 0.8 msec. Horizontal retrace time Within 10 μsec.</p>
		<p>Picture performance Normal scan 5% overscan of CRT effective screen area (adjustable range more than ±15%) Underscan 3% underscan of CRT effective screen area (adjustable range more than ±15%)</p>

* The input level of a component signal conforms to the EBU "N-10" standard. (BVM-1410P only)

Linearity Within a central area bounded by a circle whose diameter equals the picture height, within 0.5% of the picture height, out of area 1%

Color temperature D6500, adjustable to other color temperatures

Nominal chromaticity coordinates

EBU standard phosphor

	x	y
Red	0.64	0.33
Green	0.29	0.60
Blue	0.15	0.06

Convergence error Error: Less than ± 0.005
Central area: Less than 0.3 mm
Periphery: Less than 0.6 mm

Calibrated constant 40 fL at peak white of standard 1 Vp-p signal

Raster size stability Less than 1% picture height, 0% to 100% APL at 40 fL peak luminance

Scan delay Horizontal: Approx. $\frac{1}{4}$ line
Vertical: Approx. $\frac{1}{2}$ field

Resolution More than 700 TV lines (center, at 40 fL luminance)

Environment

Operating temperature 0 to 40°C (32 to 104°F)

Optimum temperature range 20 to 30°C (68 to 86°F)

Humidity 0 to 90%

Altitude Approx. 3,050 m (10,000 feet)

General

Picture tube protection EHT (Extremely High Tension) is shut off in the event of scan failure.

Warm up 30 minutes to meet specifications

Anode voltage Properly adjusted HV 25 kV at zero beam current

Power consumption Typical: 142W
Maximum: 160W
100 - 120V AC 2.7 A
220 - 240V AC 1.4 A

Power requirements 220 - 240 or 100 - 120V AC $\pm 10\%$, adjustable, 50/60 Hz

Dimensions 426 x 281.5 x 489 mm (w/h/d)
(16 $\frac{7}{8}$ x 11 $\frac{1}{8}$ x 19 $\frac{3}{8}$ inches) incl. projecting parts and controls

Weight 32 kg (70 lb 9 oz)

Supplied accessories AC power cord (1)
Cord stopper (1)
Screwdriver (1)
Drawer keys (2)
Extension board (1)
10-pin connector (1)
Fuses (3)
Tally number plates (1 set)
Operation and maintenance manual (1)

Design and specifications subject to change without notice.

1-7. PACKING

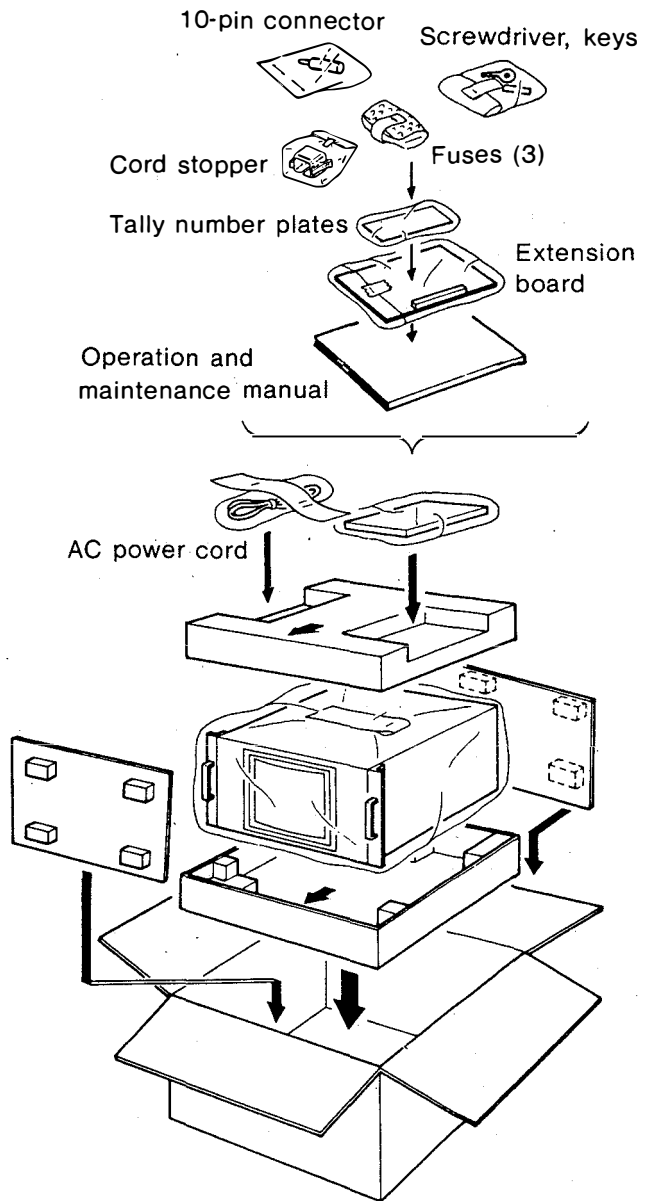

SECTION 2 DISASSEMBLY

2-1. CABINET REMOVAL AND THE SIDE PANELS

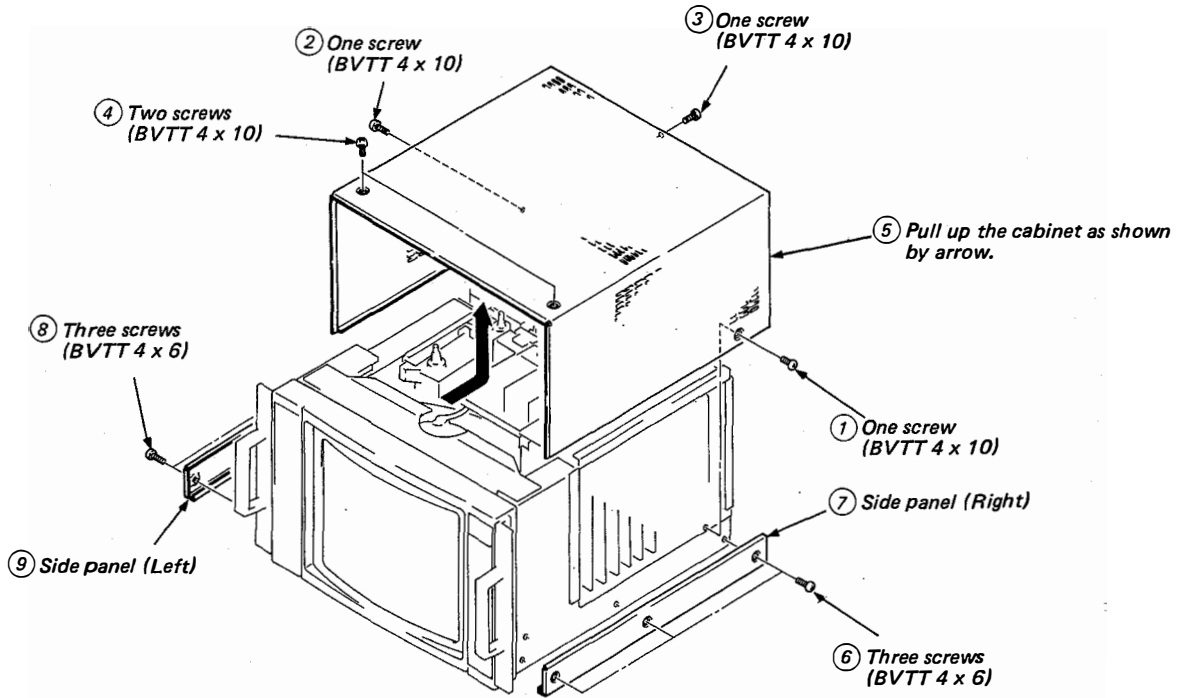

2-2. BEZEL ASSEMBLY REMOVAL

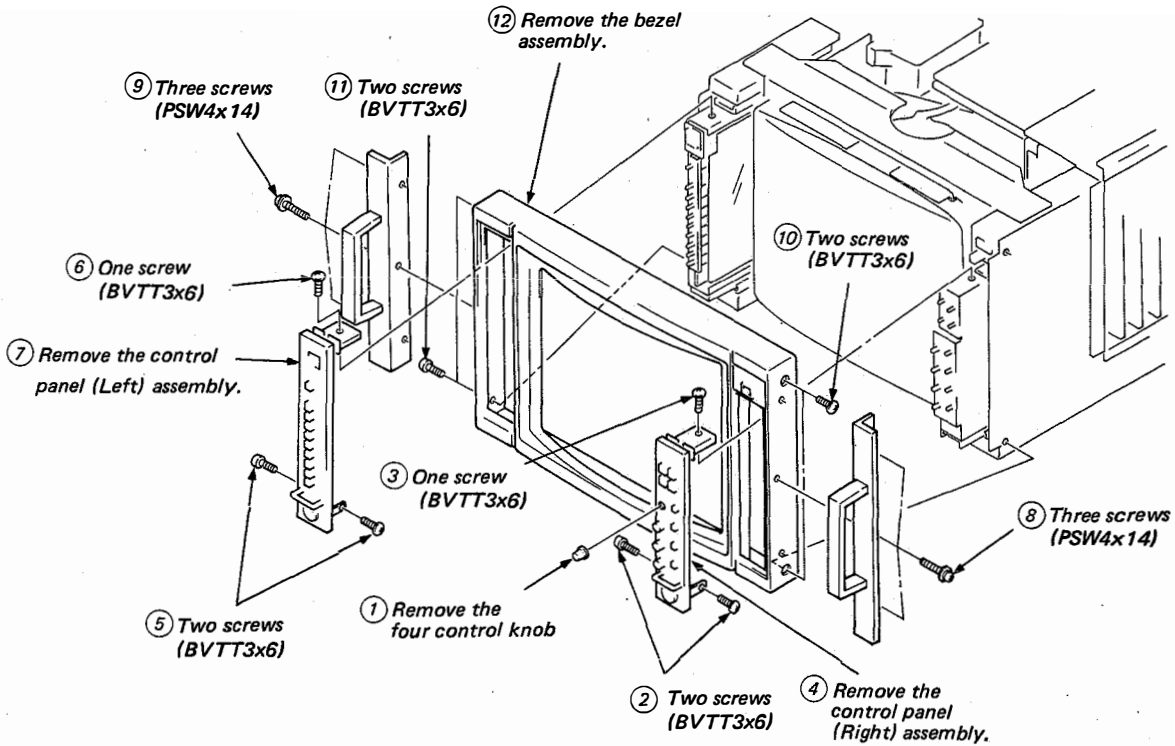

2-3. BOTTOM COVER REMOVAL

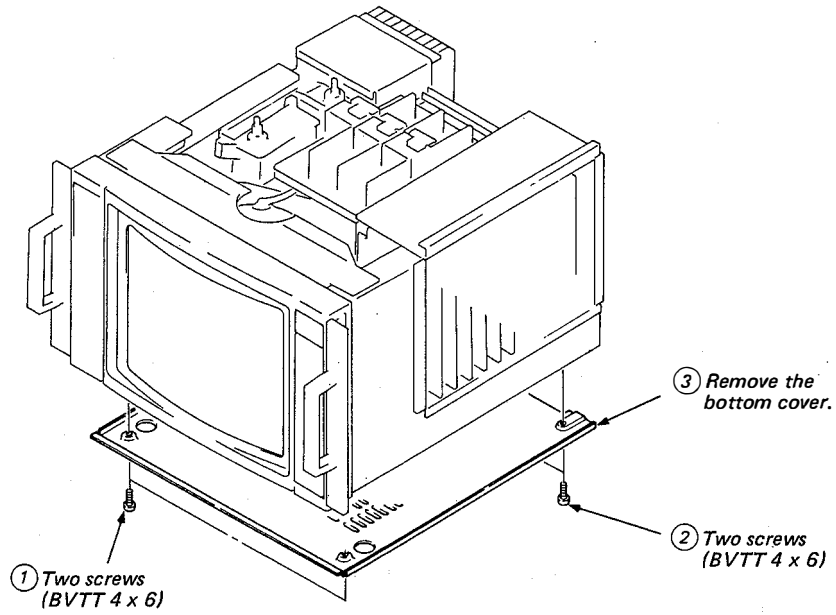

2-4. CHECK OF C BOARD

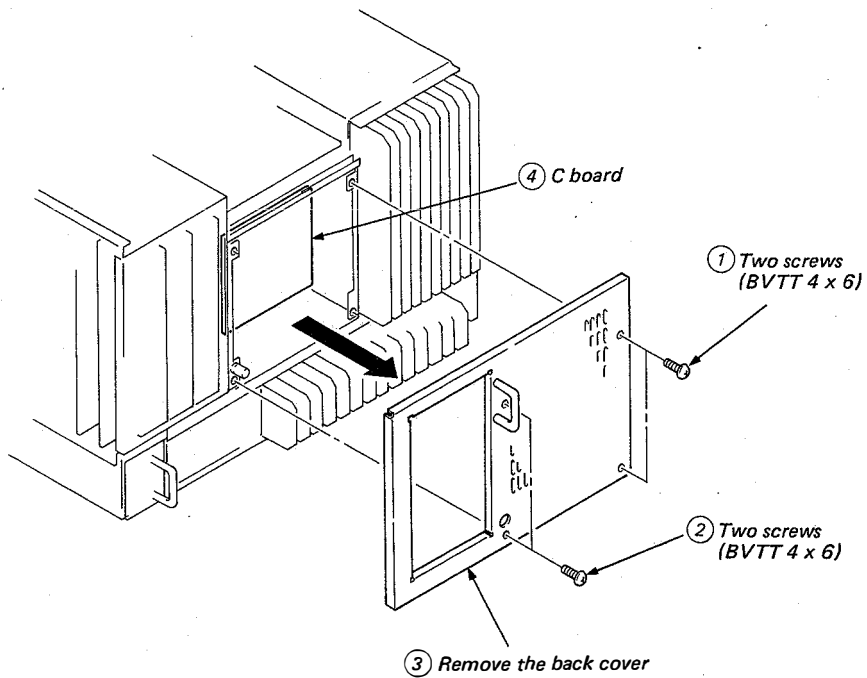

2-5. BK BLOCK REMOVAL

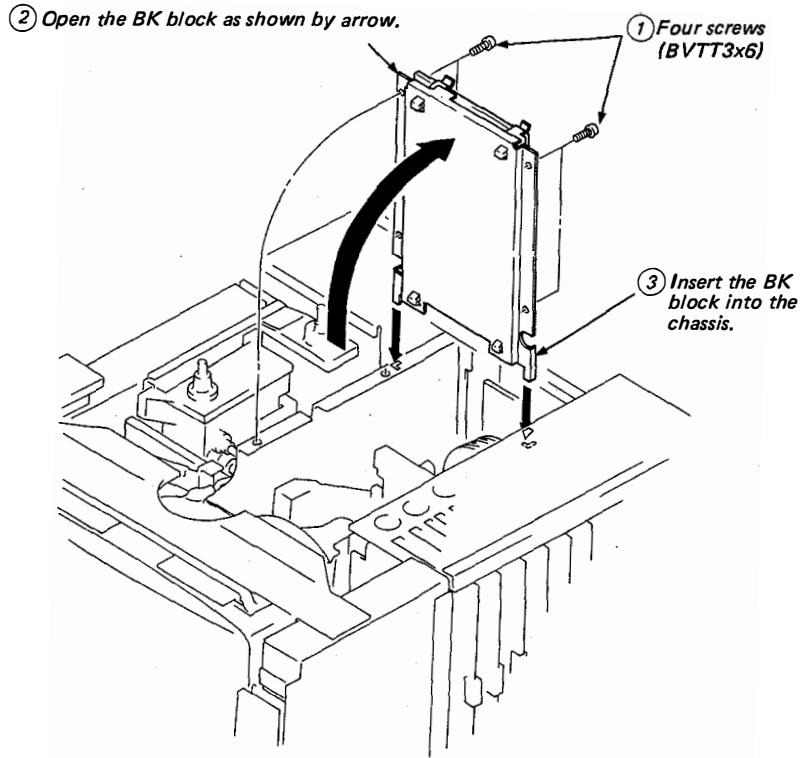

2-6. CHECK OF BK BOARD

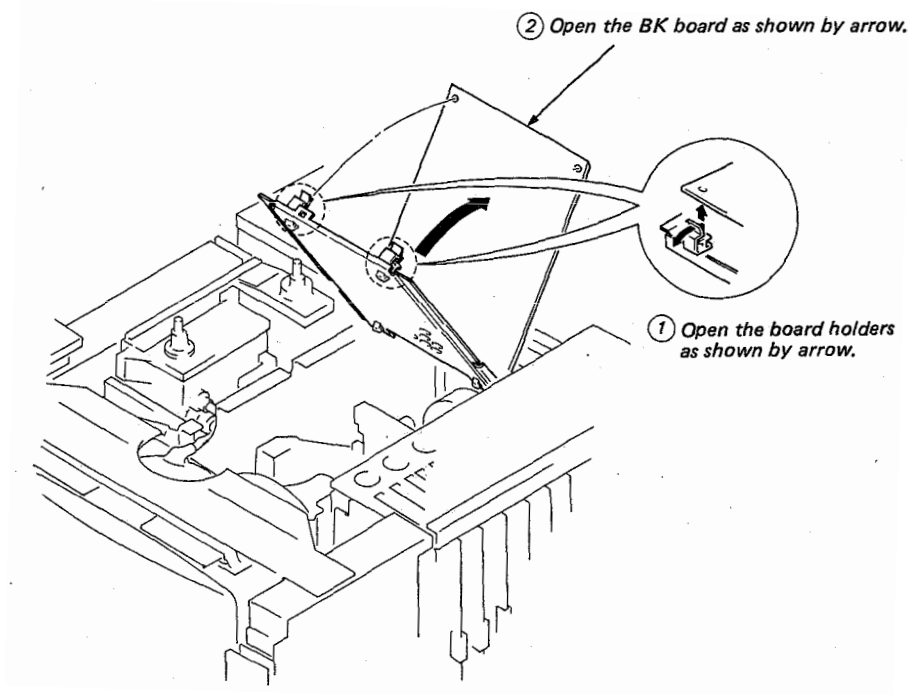

2-7. CHECK OF BJ BOARD

Note: The BA, BD or BM, BG, BH and BI boards can be checked in the same way of the BJ board.

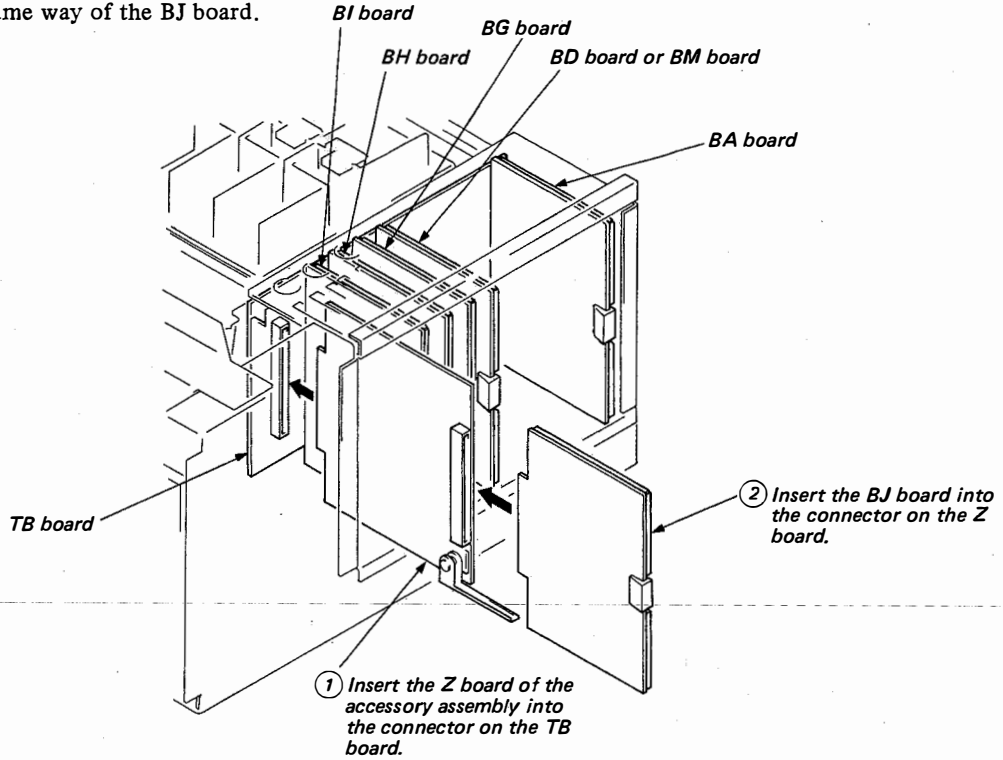

2-8. GC BOARD REMOVAL

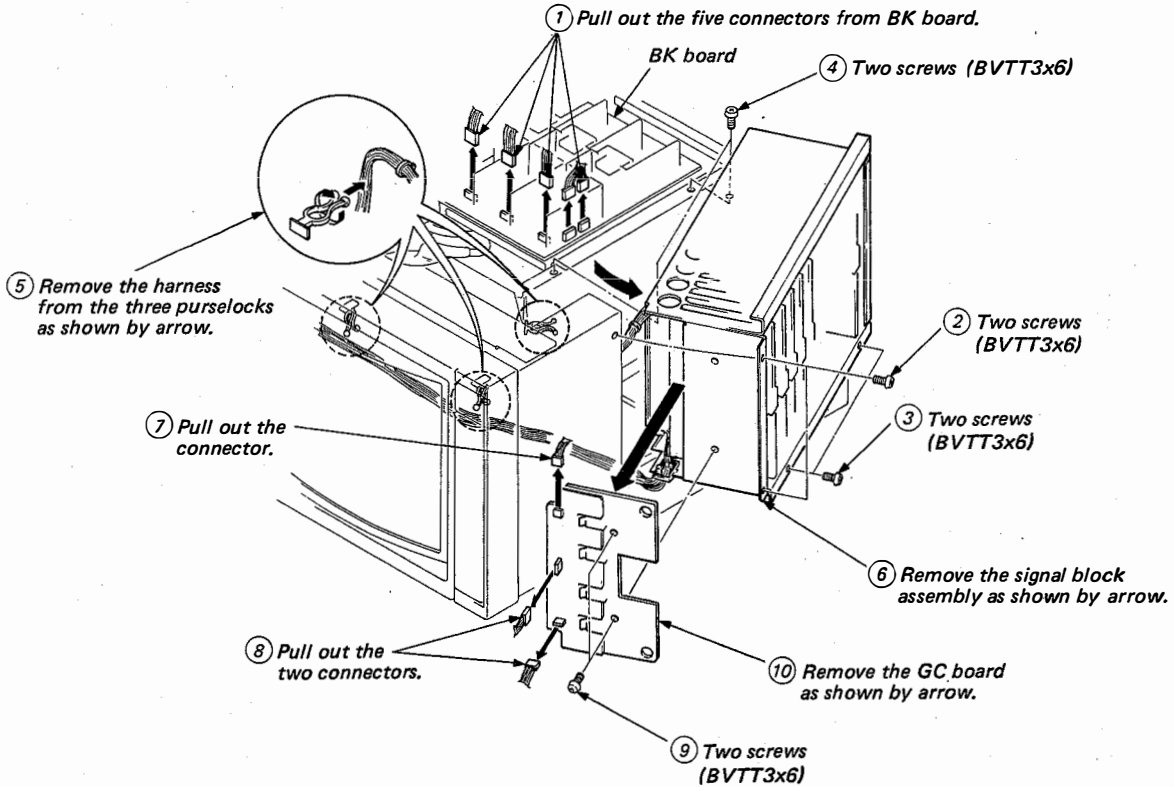

2-9. QA, W AND V BOARDS REMOVAL

Note: Connector panel (B) assembly can be removed in the same way.

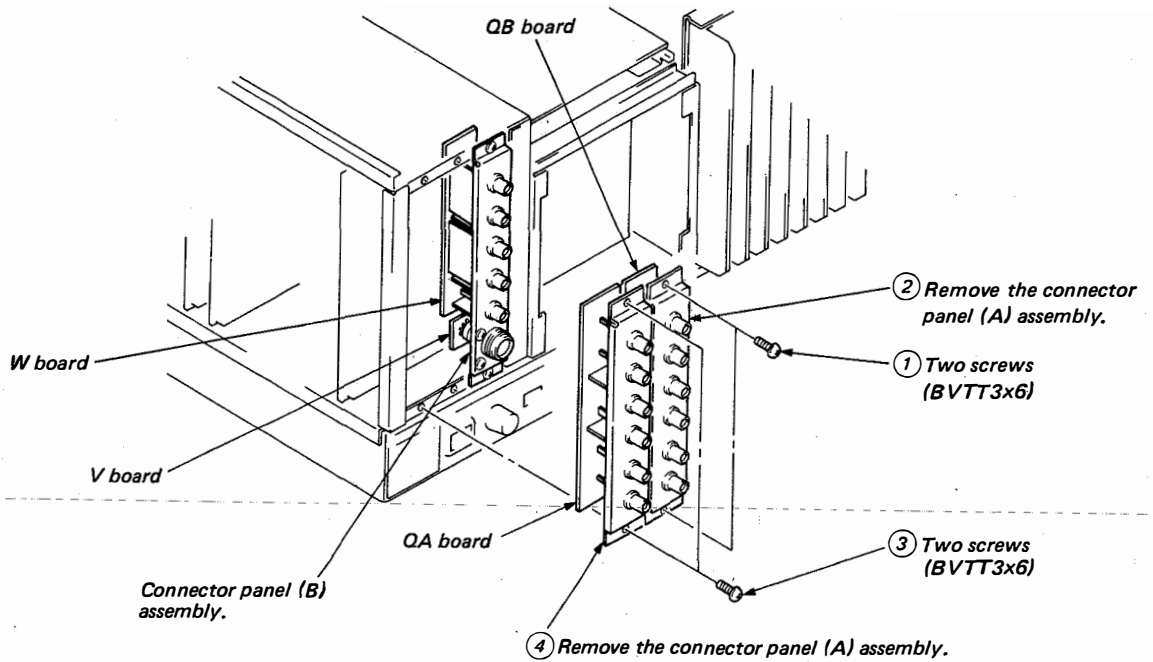

2-10. FLYBACK TRANSFORMER AND HIGH VOLTAGE BLOCK REMOVAL

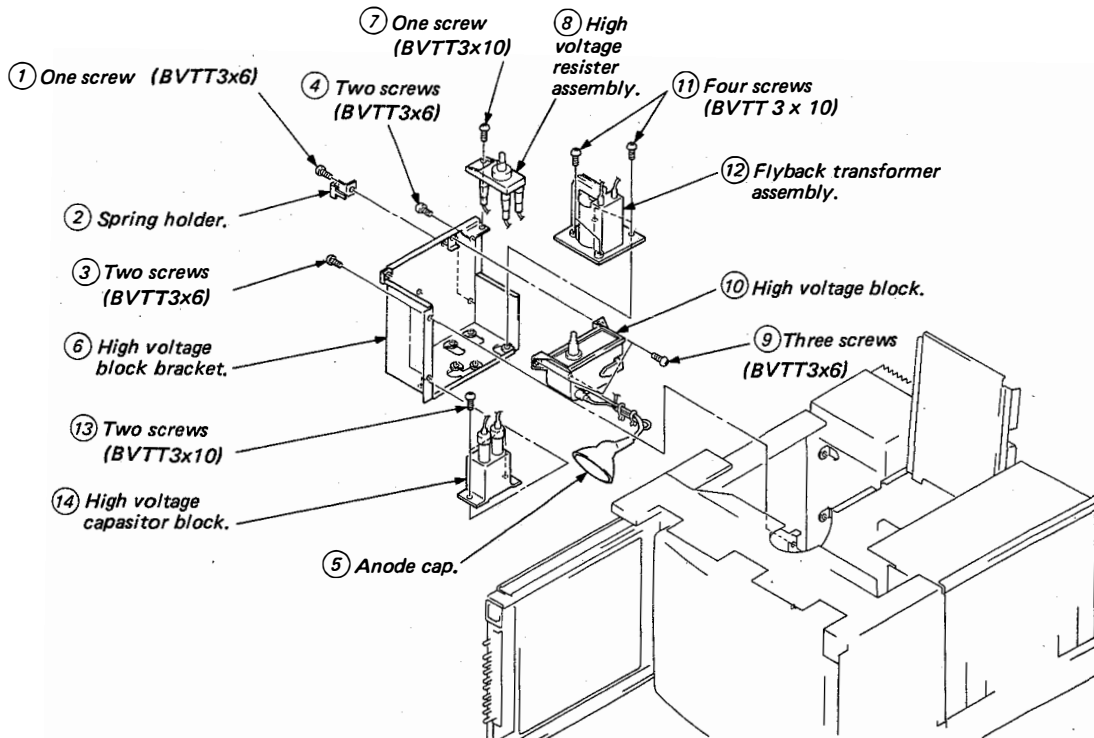

2-11. PICTURE TUBE REMOVAL

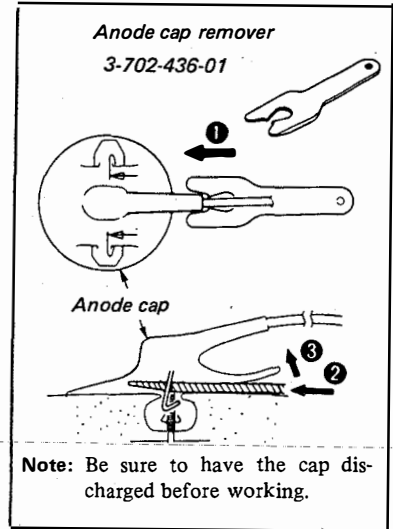
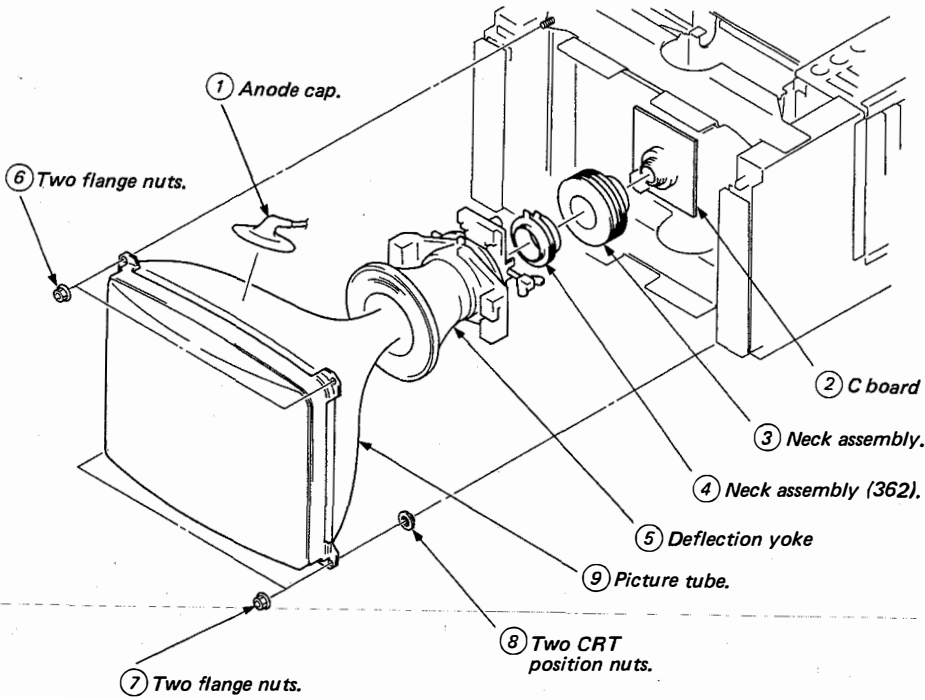

2-12. CHECKING OF PA BOARD

Note: The EA, EB boards can be checked in the same way.

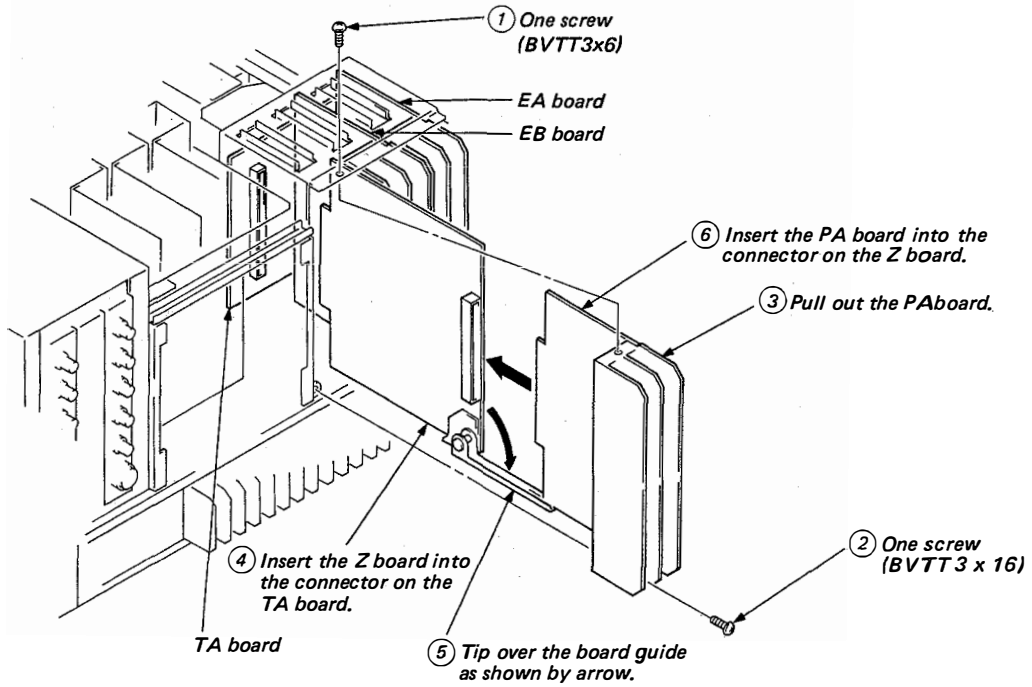

2-13. POWER BLOCK ASSEMBLY REMOVAL

Note: Remove the bottom cover before the follow operations.

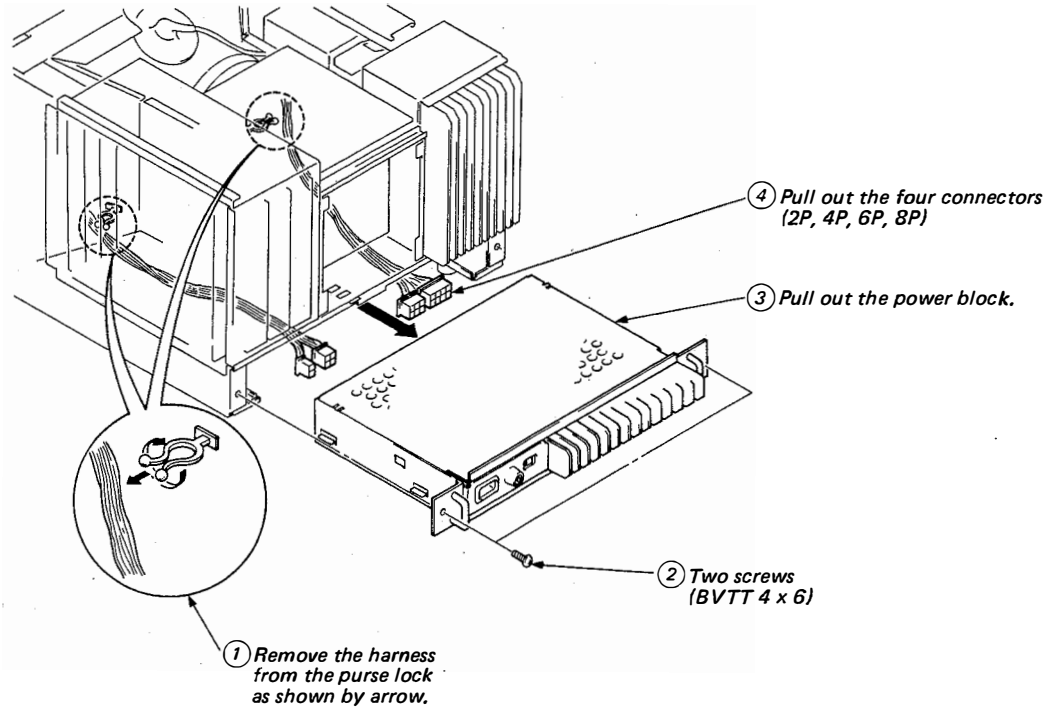

SECTION 3 CIRCUIT DESCRIPTIONS

3-1. QA, QB, BA BOARDS

3-1-1. Input Circuit

Cable Compensation (QA, QB)

CABLE COMPENSATION is composed of inductance L and capacitor C1 (Figure 1) in QA board and performs return loss compensation.

Grounding or floating in input terminal can be selected by switch S1.

On floating mode, common mode rejection can be performed. QB board also has same function.

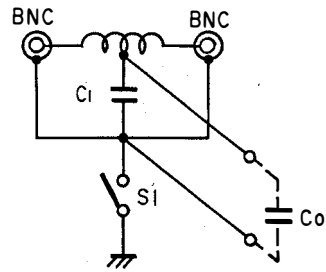

Figure 1

Hook Up Circuit (BA)

This circuit is composed of transistors Q101-105 and performs common mode rejection when SW S1 is selected to the floating mode.

In Figure 2, Gains of amplifier for input A and B are derived as follows.

$$A = \frac{R_c}{R_i} : \text{Gain of amplifier for input A}$$

$$B = -\frac{R_c}{R_i} : \text{Gain of amplifier for input B}$$

When input (ec + ei) is applied to input A and input (ec - ei) to input B, then output eo is

$$e_o = \frac{R_c}{R_i}(e_c + e_i) + (-\frac{R_c}{R_i})(e_c - e_i) = 2\frac{R_c}{R_i}e_i$$

This equation indicates that ec is eliminated and there is no common mode signal in output signal.

On hook up circuit, NF Amplifier (Negative Feedback) is used to get frequency response flat.

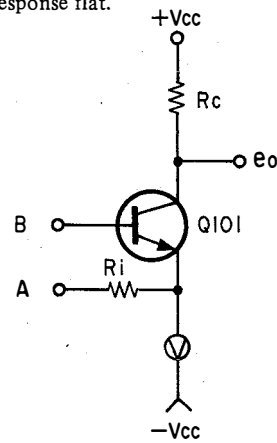

Figure 2

Input Select Sw, Sync Select SW (BA)

For composite video signal, VIDEO A/B/TEST mode is selected by INPUT SELECT SW (IC1). For sync signal, INT SYNC/EXT SYNC is selected by SYNC SELECT SW IC2.

3-1-2. Sync AGC Circuit

This circuit is composed of following components; LPF (Low Pass Filter) (Q701), variable gain amplifier (Q702-Q705), bias control circuit (Q708-Q710), gain control circuit (Q711, 712) and amplifier (Q706, 707), Figure 3 shows block diagram of this circuit.

An inverted composite video signal or composite sync signal (eo) is derived at the collector of transistor Q707.

The bias control circuit compares maximum value of eo with base voltage of Q708 (E1) and controls bias of amplifier so that they match.

Also the gain control circuit compares pedestal level of eo with base voltage of Q711 (E2), and controls variable gain amplifier so that they match.

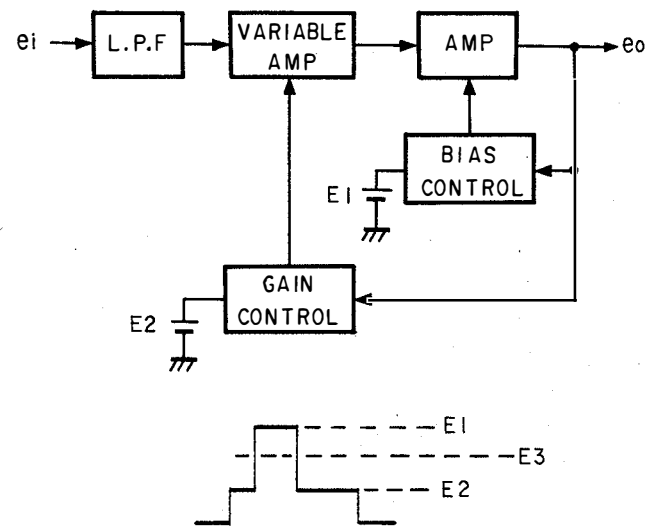

Figure 3

Composite Sync Separation, Vertical Sync Separation

Composite sync is separated from composite video signal or composite sync by comparing voltage eo with the base voltage of transistor Q713 (E3).

Horizontal component in composite video signal or composite sync signal is removed by LPF (Low Pass Filter, Q716) and Vertical sync is separated by transistor Q717.

BLOCK DIAGRAM OF QA, QB, BA BOARDS

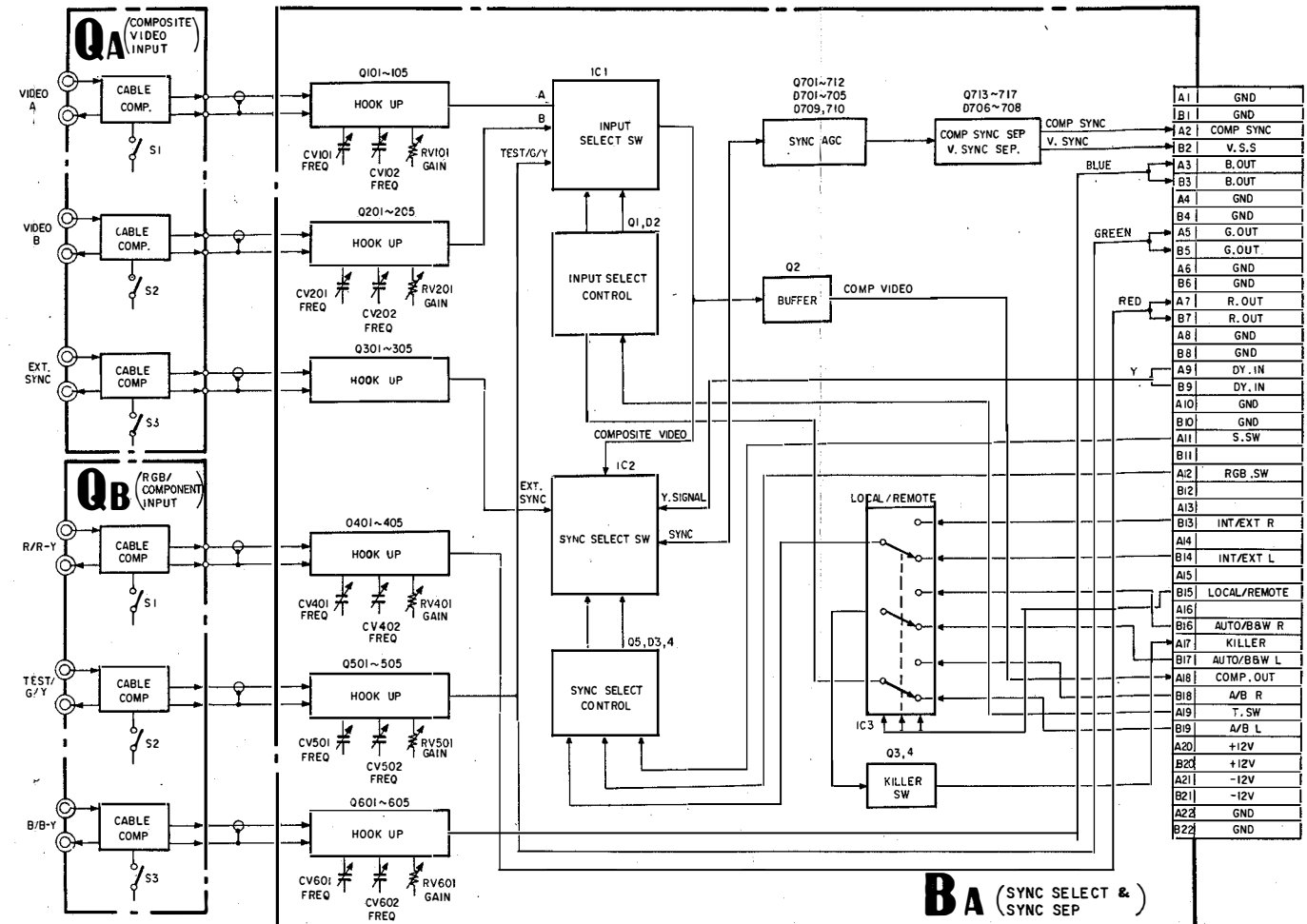

3-2. BG BOARD

3-2-1. Luminance Signal Circuit

Filter SW

IC1 works as a selector switch of composite video signal or luminance signal derived from Y/C separation circuit. This IC activates by either FILTER-SW in right side drawer or killer signal.

Aperture Control

Aperture control circuit is composed of DL1(delay line), transistors Q5, 7, 8 and IC2. IC2 operates as a variable resistor. Resistance value between Pin ① and ③ is controlled by the potential between pin ③ and pin ④, also pin ① and pin ⑥.

Input signal: e_{r0} ,
Delayed signal by delay line: e_{r1}
Second delayed signal: e_{r2}

See Figure 4
 e_1 (at base of transistor Q5) is obtained as below due to the combination of direct wave and reflected wave by DL1

$$e_1 = (e_{r0} + e_{r2})/2$$

Therefore e_0 is

$$e_0 = -(e_{r1} + \frac{1}{K}(e_{r1} - \frac{1}{2}(e_{r0} + e_{r2})))$$

K: variable constant

In the above equation, 1st term shows waveform A in Figure 5 and 2nd term shows waveform B. When K is variable, amount of pre-shoot and overshoot can be varied.
Switch S1 is used for selection of boost frequency.

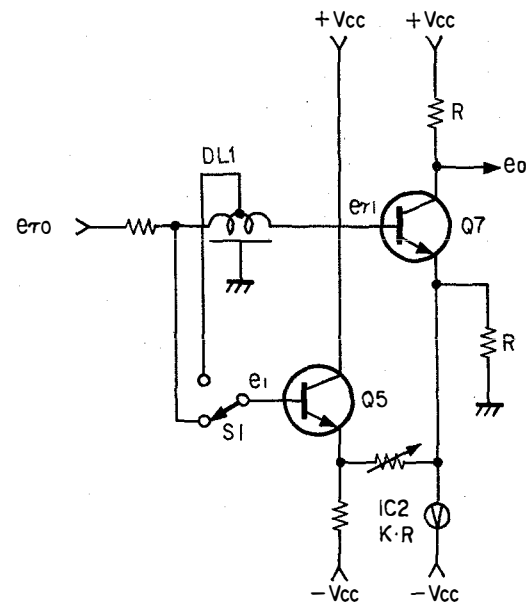

Figure 4

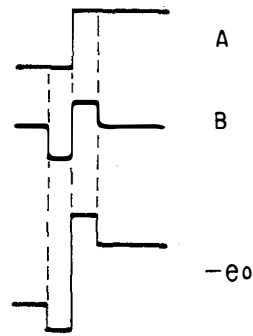

Figure 5

Y Delay, Y Buffer Amplifier

Y/C delay time can be matched by delay line DL2 and Y signal is amplified and fed to the next stage.

3-2-2. Color Gain Control Circuit

In this section (R-Y) signal processing is described as below, but (B-Y) signal is processed by the same way as (R-Y) signal.

R-Y Amplifier and Clamping

The R-Y color difference signal from the decoder board is amplified at the amplifier composed of transistors Q21 and Q22 and clamped at the Horizontal Sync by transistors Q23 and IC3.

R-Y Gain Control Amplifier

This is a variable gain control amplifier composed of variable resistor element of IC4 and transistors Q25-Q27. Gain of this amplifier can be controlled by the color gain control voltage at the pin ⑫ of IC4.

AGC Pulse Generator

Generates the reference pulse for AGC (Automatic Gain Control) of color gain control circuit.

Gain Control Amplifier for AGC Pulse

Circuit is the same as R-Y GAIN CONTROL AMPLIFIER. Gain of this amplifier is controlled by the voltage at pin ⑧ of IC4.

Color Gain Control

AGC pulse, which is output signal of Gain control amplifier for AGC pulse, is clamped by IC6 (2/3) and is made sampling by IC6 (3/3). Amplitude of AGC pulse and DC voltage supplied from CHROMA control on the front panel are compared and matched by IC7 (1/2) with controlling the above gain control amplifier. This control voltage is supplied to the control terminals of R-Y and B-Y gain control amplifiers and controls color gain.

3-2-3. G-Y MATRIX amplifier

G-Y signal is obtained by matrixing R-Y signal and B-Y signal with the amplifier composed of transistors Q44 and Q45.

3-2-4. NTSC MATRIX SW

NTSC MATRIX mode operation is obtained by the matrix circuit composed of resistor networks CP14-CP19, transistor Q29, Q30, Q39, Q40, Q49, Q50 and IC5.
IC5 works as a switch

3-2-5. Vector Output Circuit

R-Y Vector Output Gain Switcher

Vector output levels are compensated for each color standards, NTSC, PAL and SECAM.

R-Y Vector Output Amplifier and Clamping

Vector output signal is amplified by IC9 (2/2) and transistor Q54 and clamped by IC8 and transistor Q55 for the suitable operation.

3-2-6. COMPONENT R-Y Amplifier and Delay Circuit

R-Y signal of COMPONENT signal is compensated with amplitude, polarity and delay time to match the R-Y signal of decoder output.

BLOCK DIAGRAM OF BG BOARD

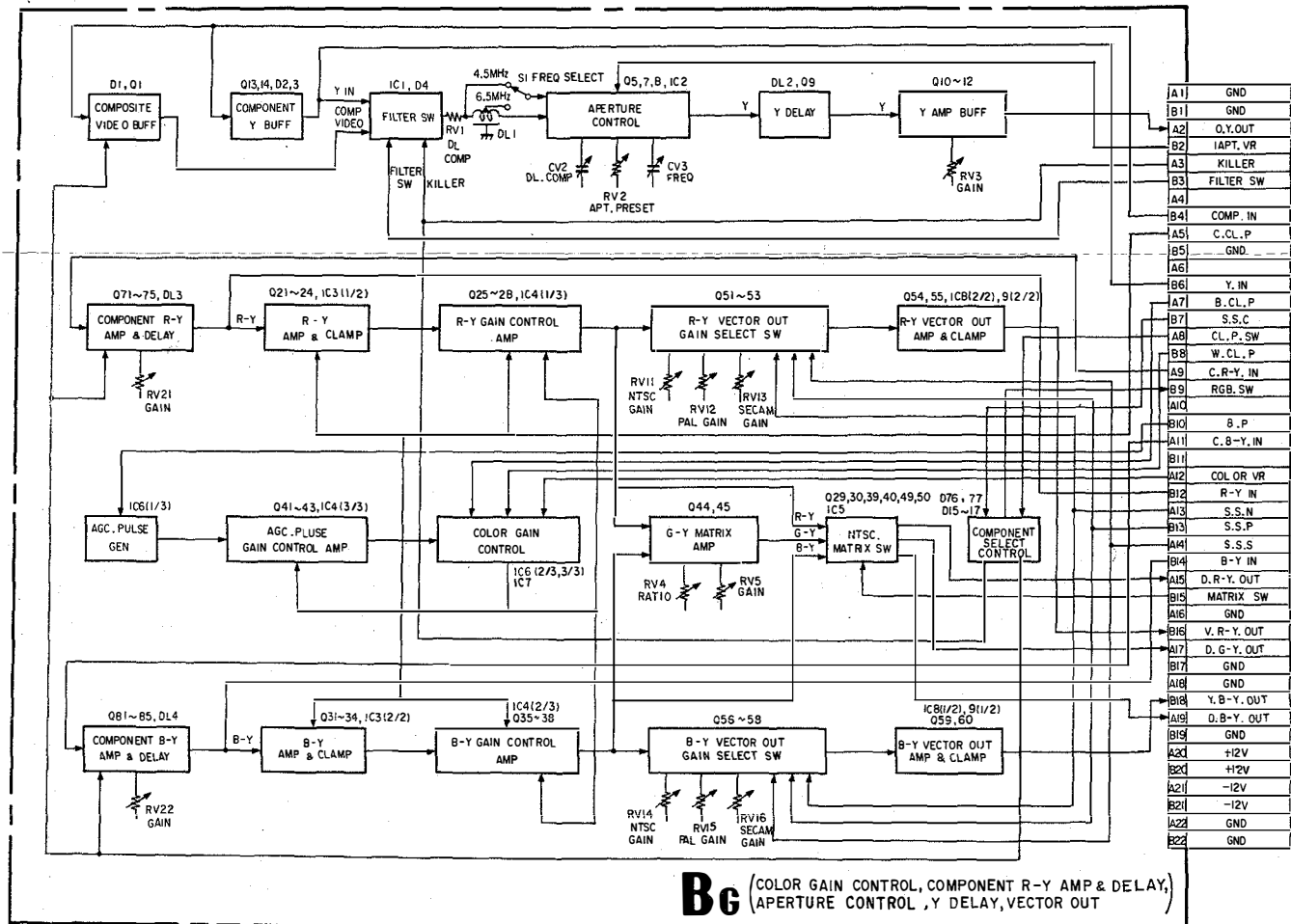

BLOCK DIAGRAM OF BH BOARD

3-3. BH BOARD

3-3-1. Switching Circuit Between Y (Luminance) Signal, Color Difference Signal and RGB Signal, AGC Pulse Insertion, Y-C Matrix

Switching Circuit of Y Signal, Crosshatch Signal and SET UP Signal, Buffer

Y signal, crosshatch signal and SET UP signal are selected by the switcher (IC1 (1/3) (2/3)) and selected signal is output via buffer Q1.

Switching Circuit of R-Y Signal, Red Signal and SET UP Signal, Buffer (Same as B-Y, G-Y Signal)

R-Y signal, Red signal, SET UP signal are selected by IC2 (1/3, 2/3) and selected signal is output via buffer Q4.

Y Signal Screening (Same as R-Y, B-Y, and G-Y Signals)

The signal is performed SAMPLE and HOLD (S/H) at the back porch of signal by transistor Q2 and IC5 (2/2). Y screening is performed by replacing S/H output signal, by the original signal. For color difference signals screening is made at the Horizontal Sync portion.

Red Matrix, Blue Only SW, Buffer (Same as Green and Blue)

Red is obtained by Y-C matrix circuit composed of resistor network CP9 from color difference signals. AGC pulse from pulse generator is inserted into Red signal for contrast control. IC7 activates by the Blue only SW on the front panel. Blue only SW is used for the display of blue signal as a monochrome picture.

3-3-2. Contrast Control, Brightness Control, Peak Limitter

Red Contrast, and Brightness Control Amplifier (Same as Green and Blue)

This is a variable gain control amplifier composed of variable resistor element IC101 and transistor Q102 and Q103. By controlling the voltage at pin ④ of IC101, contrast control is performed, and brightness control is done by controlling the bias voltage of transistor Q102.

Red limiter (Same as Green and Blue)

When excess input signal comes in, amplitude is limited by the limiter composed of transistors Q104 and Q105.

Red Contrast Control

AGC pulse inserted in Red signal is clamped by transistor Q107 and sampled by transistor Q108. Amplitude of above AGC pulse is compared with the reference voltage applied from CONTRAST control on the front panel in IC102 (2/2).

Contrast control is performed by controlling the gain of Red contrast brightness control amplifier so that these voltages may match.

Red Brightness Control (Same as Green and Blue)

The black level of Red signal is performed SAMPLE and HOLD (S/H) by transistor Q106. This S/H voltage is compared with the reference voltage applied from BRIGHTNESS control on the front panel in IC102 (1/2). BRIGHTNESS control is performed by controlling the bias of Red contrast BRIGHTNESS control amplifier so that these voltages may match.

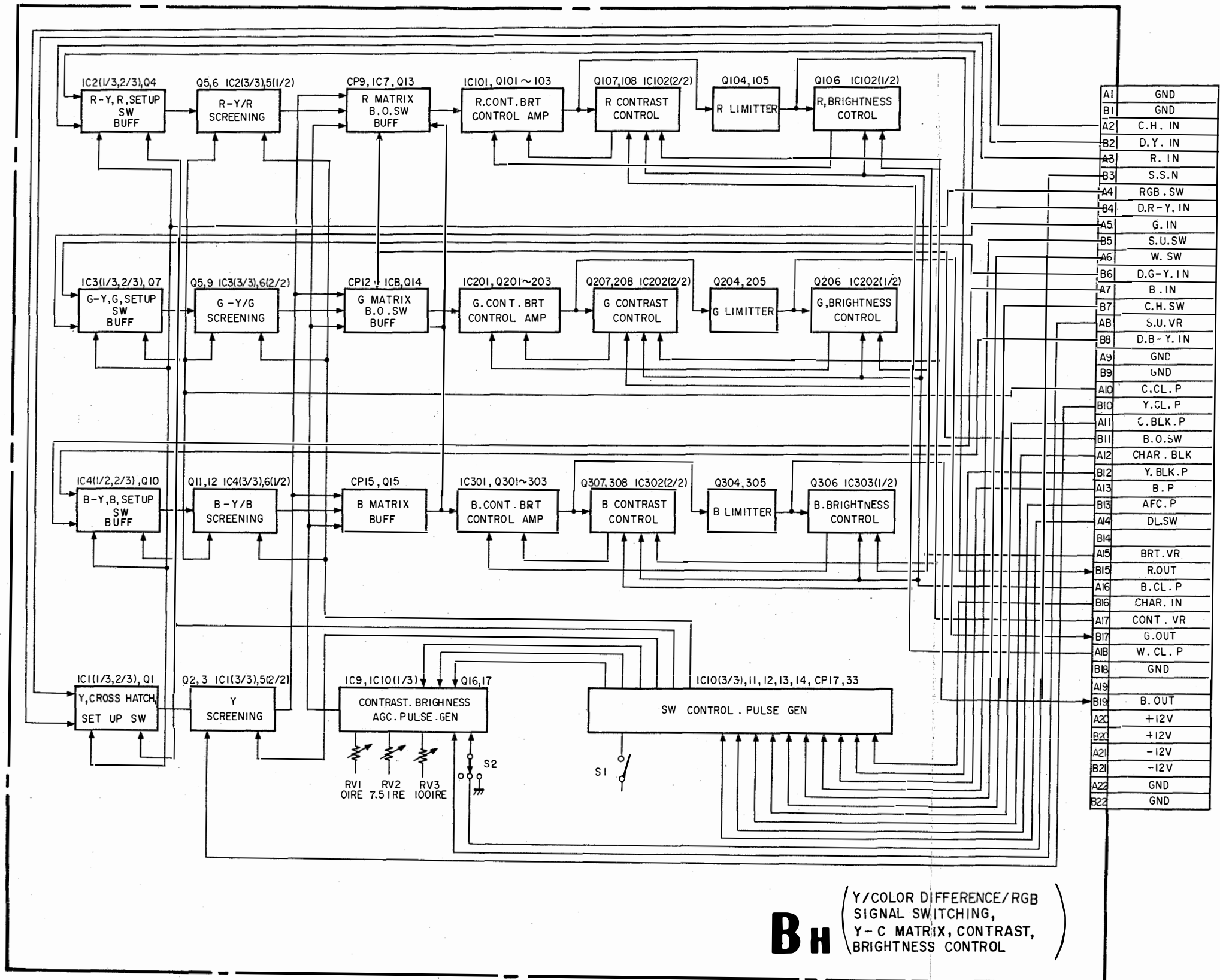

3-4. BI BOARD

3-4-1. Red Screen SW, AGC Pulse Insertion (Same as Green and Blue)

Red signal can be cut off by RED SCREEN SW on the front panel. Horizontal rate AGC pulse is removed and the reference pulse is inserted in the signal for the GAIN and BIAS adjustment of video output amplifier and for the beam control circuit.

3-4-2. Red Limiter, Gain and Bias Control Amplifier

This limiter is used for limiting the excess input level of the signal below 0V DC.

The GAIN BIAS CONTROL amplifier is composed of variable resistor element and transistors as same as contrast control amplifier' (See section of BH board)

3-4-3. Red Feedback Amplifier, Red Gain Control Red Bias Control Circuit

RED FEEDBACK amplifier inverts the phase of the signal derived from VIDEO OUTPUT amplifier via NF BUFF (Negative Feedback Buffer) in BK board.

The BIAS of VIDEO OUTPUT AMPLIFIER is controlled by RED BIAS CONTROL circuit so that the black level of inverted signal may be 0V DC.

(This time, black level of VIDEO OUTPUT will be -90V DC.)

RED GAIN CONTROL circuit controls the gain of VIDEO OUTPUT AMPLIFIER so that the level of the reference pulse may match to the voltage at pin ③ of IC103.

(When GAIN control (RED) in the drawer is turned, the level of the reference pulse inserted in section 1 changes. And amplitude (Gain) of Red signal changes so that the amplitude of the reference pulse derived from RED FEEDBACK amplifier may be maintained constant by GAIN CONTROL circuit.)

3-4-4. Red Cathode Current Detection, Red G1 Control Circuit (I-V Conversion)

Refer to the BK board section of beam control circuit

3-4-5. ABL Detector, Drive Control, Over Drive

The reference level of GAIN CONTROL circuit is controlled by ABL detector and DRIVE CONTROL so that the cathode current of CRT exceeds the predetermined (Preset) value to prevent damage of CRT. OVER DRIVE circuit lights up the OVER LOAD LED on the front panel for warning.

3-4-6. G2 Control Circuit

Circuit diagram of G2 control circuit is shown in Figure 6.

The signal for G1 BIAS control is fed to base of the transistor Q11 from RED G1 BIAS control circuit. (Same as G and B)

Only one of the highest voltages among the base voltages of transistors Q11-Q13 is turned on and is compared with the reference voltage of base voltage Q14.

And this circuit drives transistor Q105 located in PA board so that Transistor Q105 in PA board drives G2 voltage for adjusting cut off level of CRT.

Base voltage of transistor Q14 (reference voltage) is set so that the voltage of Black level at G1 electrode may be -120V DC and maintain Ekco (cut off voltage) -120V constant.

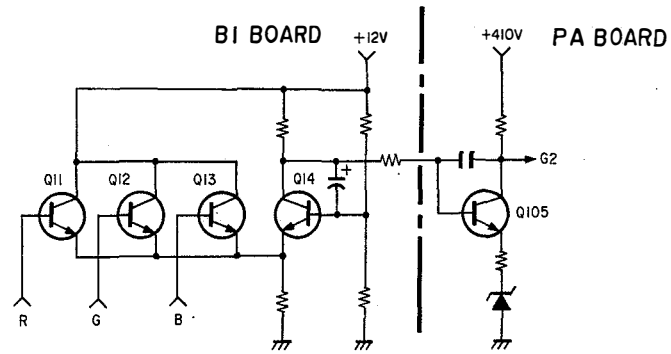
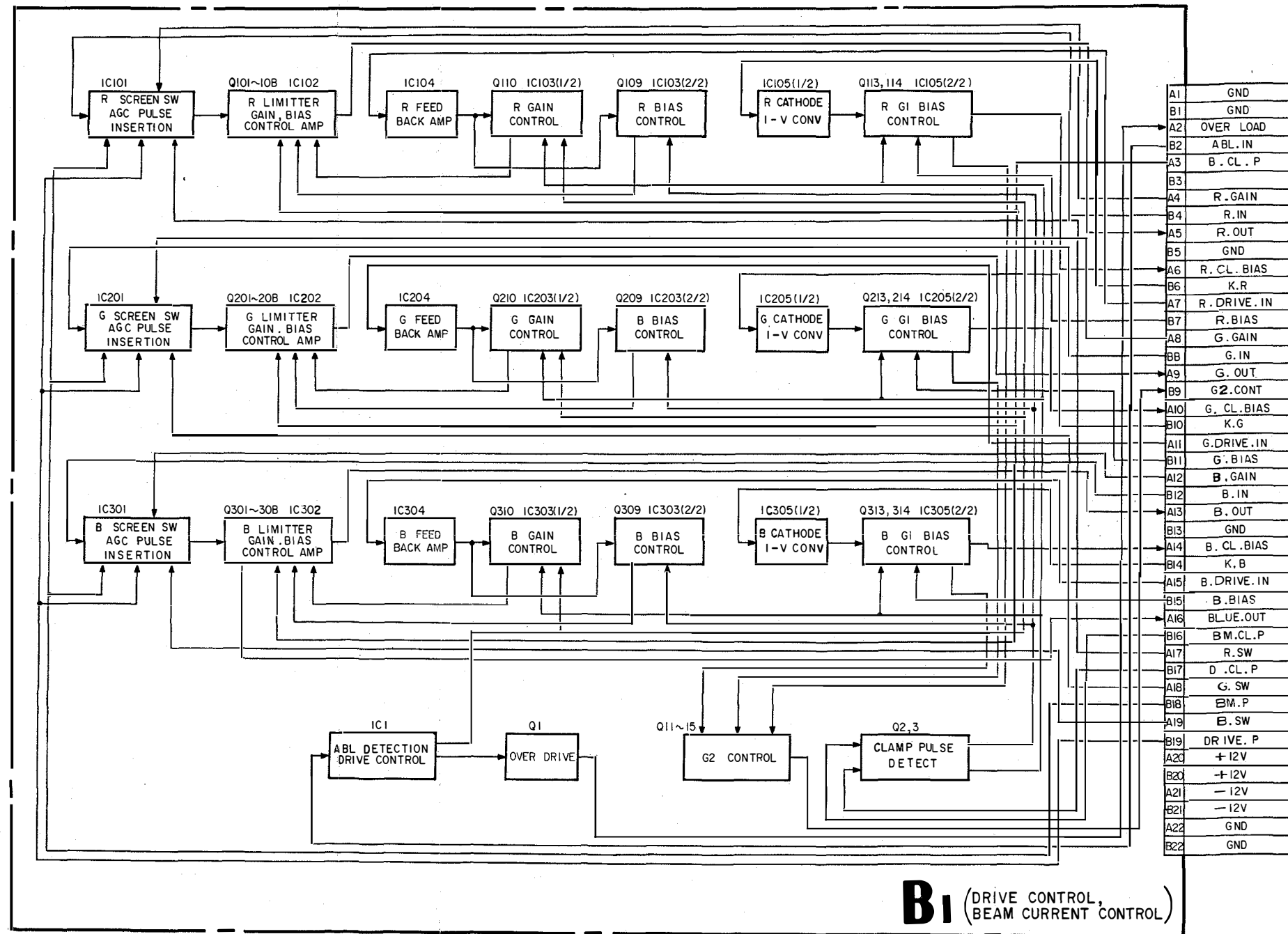

Figure 6

BLOCK DIAGRAM OF BI BOARD



3-5. SYNC PROCESSOR, PULSE GENERATOR (BJ BOARD)

3-5-1. 1H Pulse Processing

The composite sync is separated from incoming signal at BA board. And 1H sync is made by separating V sync and equalizing pulse from composite sync.

Also H sync which has constant pulse width is made from 1H sync.

3-5-2. 2fH Multivibrator

This circuit generates 2fH rate pulse from H rate flyback pulse.

3-5-3. Vertical Counter

The 2fH rate pulse is counted down to generate Vertical rate trigger pulse for vertical deflection circuit.

When there is no incoming signal, trigger pulse is generated by vertical counter.

When there is incoming signal with V sync, this counter circuit is reset by V sync and generates trigger pulse synchronized with V sync.

Also in order to increase stability of vertical scanning, noise gating process is made during V sync period.

3-5-4. V Sync and Delay

V sync and V BLANKING pulses are generated by output trigger pulse from vertical counter.

And when V DELAY SW on the front panel is selected ON, these pulses are generated in a V/2 delayed position relative to the V sync position of incoming signal.

3-5-5. Crosshatch Generator

Internal crosshatch signal is made as follows.

The vertical lines are generated by approx. 18fH rate pulses synchronized with flyback pulse.

And flyback pulse is counted down to generate horizontal lines.

3-5-6. Burst Gate Pulse, Y-CLAMP Pulse, C-CLAMP Pulse Generator

The Burst Gate Pulse (B.G.P.), clamp pulse for luminance signal (Y.CL.P) and clamp pulse for color difference signal (C.CL.P) are generated from 1H sync via LCR network and transistors.

3-5-7. Picture Set Up Pulse Generator

This is the gate pulse generator for picture set-up function, and consists of mono multipliers.

3-5-8. Split, Y Blanking, C Blanking Pulse Generator

Y BLANKING pulse (Y BLK P) and C BLANKING pulse (C BLK P) are generated. These pulses are used for the purpose of DC restoration of color difference signal, Y signal and RGB signal. DC restoration is made by inserting the black reference signal during blanking period in the signal. Also C.BLK. pulse is mixed with vertical rate blanking signal for SPLIT display.

3-5-9. Horizontal Rate AGC and Clamp Pulse Generator

COLOR GAIN control, CONTRAST control and BRIGHTNESS control are stabilized by insertion of reference signal and using feedback circuit. Horizontal rate BLACK pulse (B.P), BLACK CLAMP pulse (B.CL.P) and WHITE CLAMP pulse (W. CL.P) are generated here.

3-5-10. Vertical Rate AGC and Clamp Pulse Generator

In this model, BEAM CONTROL circuit is used for high stability in white balance.

The reference signal is inserted in the signal for gain control circuit in video output amplifier and for beam control circuit. Vertical rate pulses are used for this purpose.

Vertical rate BEAM PULSE (BM.P) DRIVE PULSE (DRIVE.P) and BEAM CLAMP PULSE (BM.CL.P) are generated here.

3-5-11. Others

Black reference is determined at the position of clamping in black reference insertion circuit for both color difference signal and RGB signal. Accordingly C.CL.P is used as clamp pulse for color difference signal processing and Y.CL.P is for RGB signal. CLAMP PULSE SELECTION SW switches C.CL.P. or Y CL.P to the clamp pulse for the insertion of black reference.

BLOCK DIAGRAM OF BJ BOARD

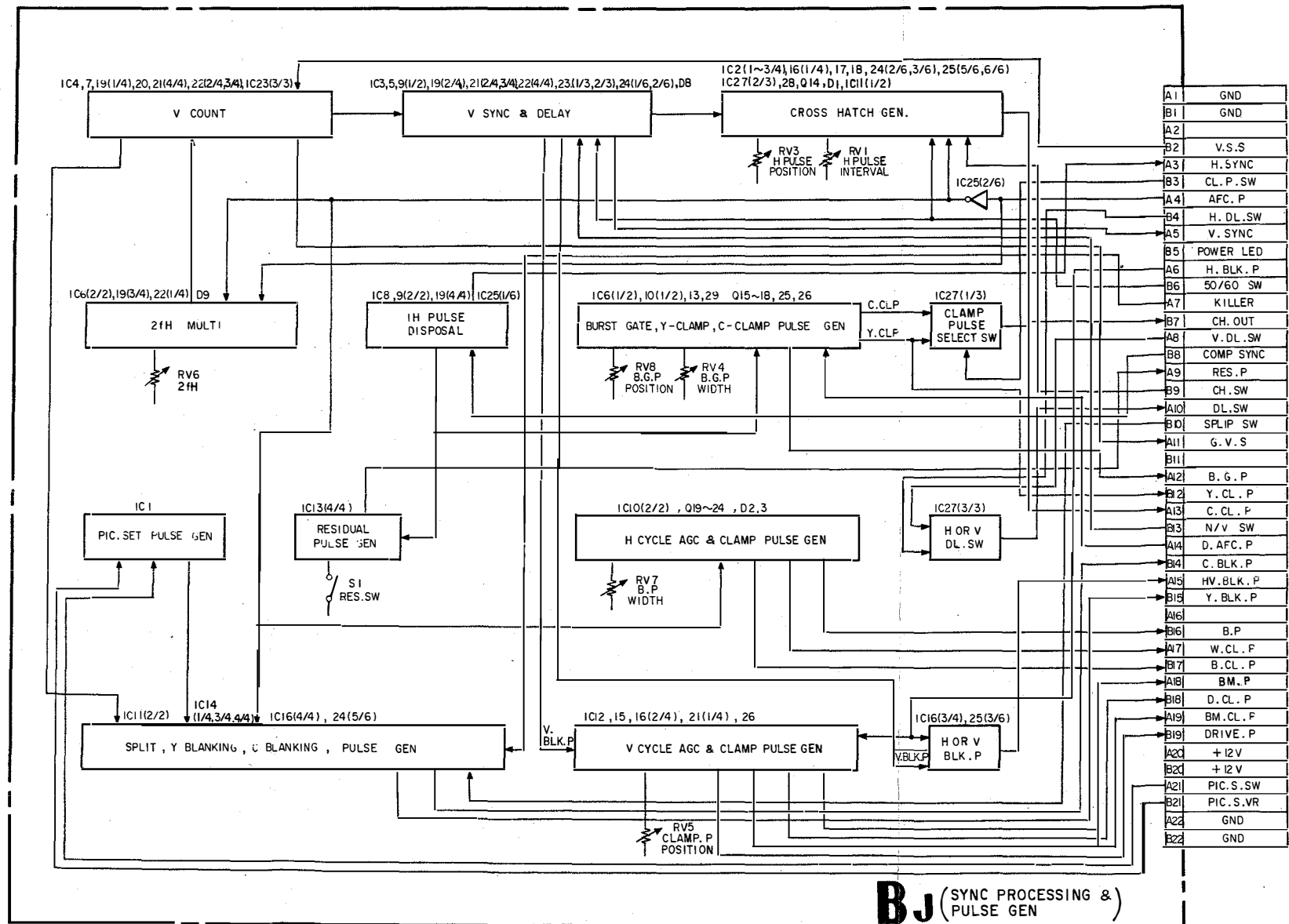

TIMING CHART OF MAJOR PULSE (BJ BOARD)

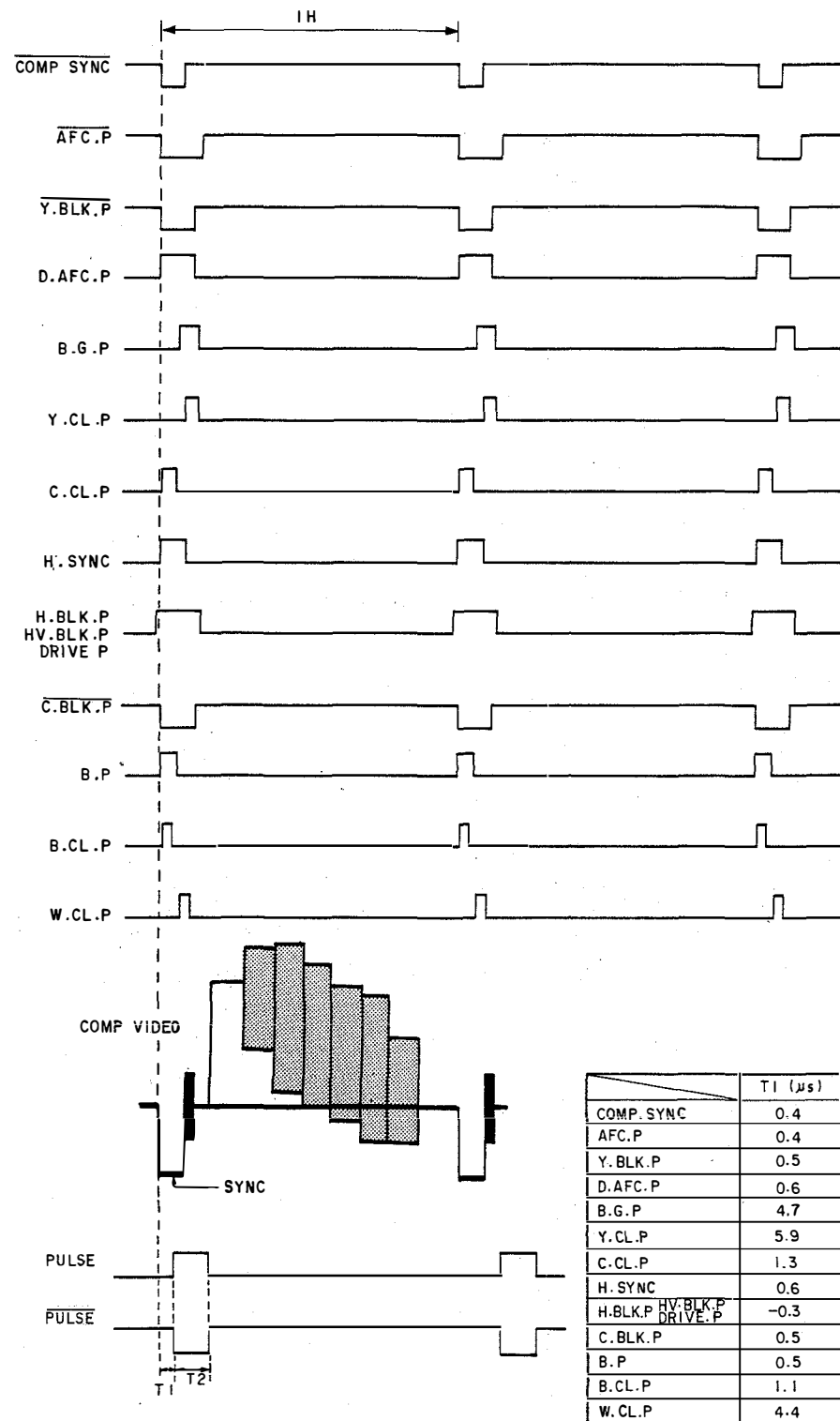

Figure 7

FIELD 1 VERTICAL BLANKING

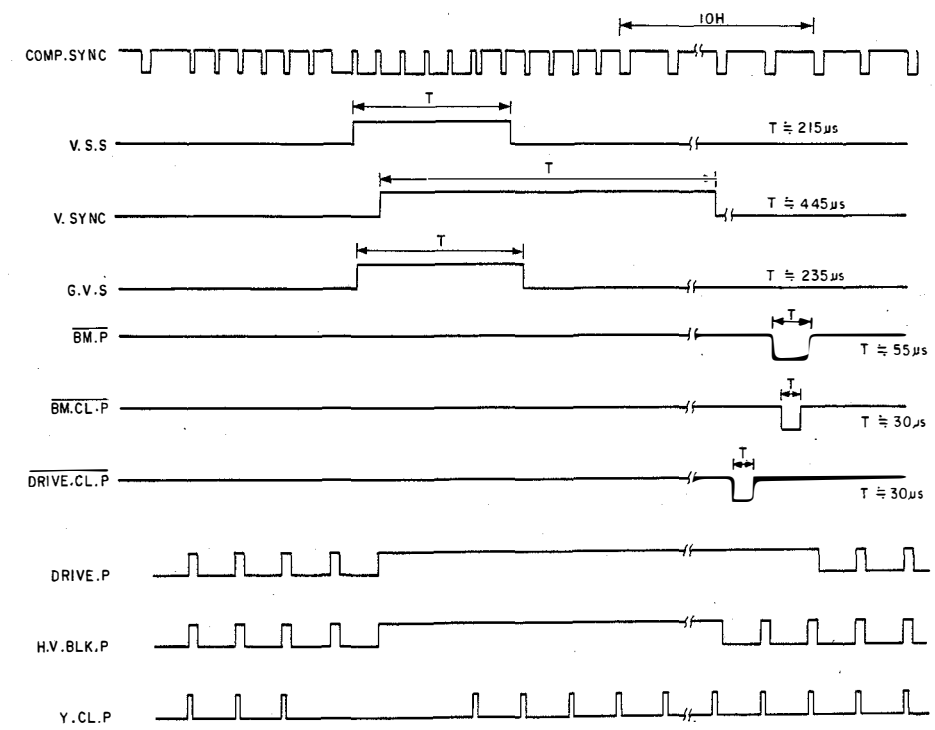

Figure 8

FIELD 2 VERTICAL BLANKING

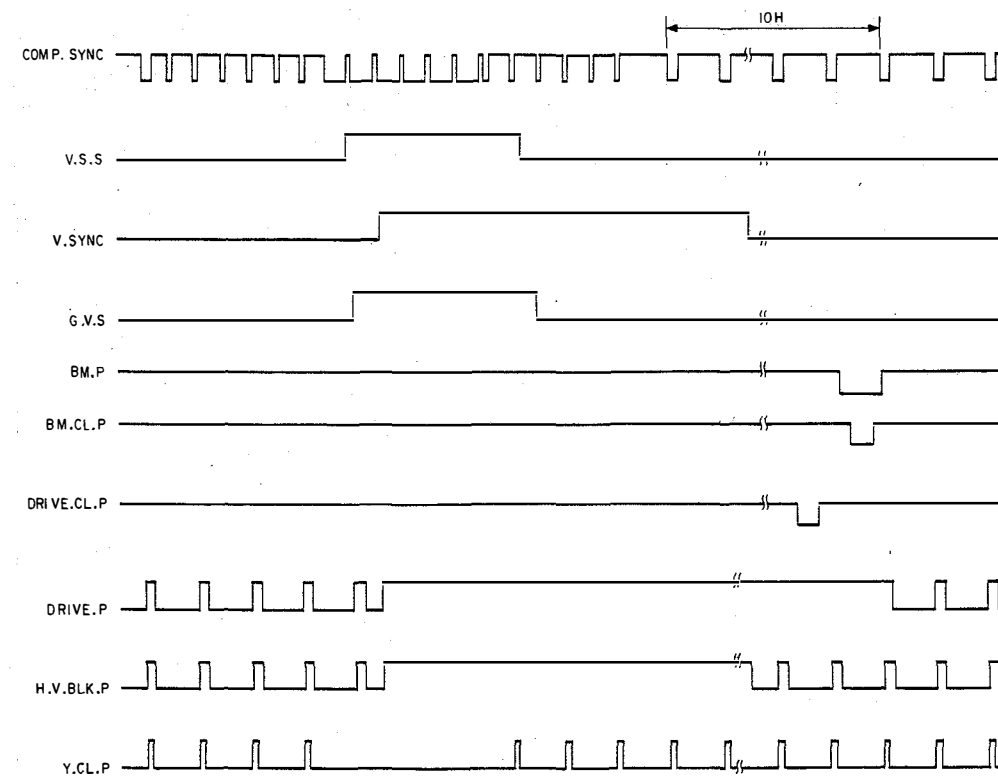

Figure 9

3-6. BK BOARD

Following are described about Red channel. Green and Blue channel are the same.

3-6-1. Red Drive Amplifier, Red Buffer

This circuit drives final stage of video output amplifier. Gain is approx. 2

3-6-2. Red Video Output Amplifier and Buffer

This is the final stage amplifier to obtain amplitude enough to drive G1 of CRT.

Gain is approx. 14

Also in this amplifier, BLANKING pulse is mixed with video signal.

BLOCK DIAGRAM OF BK BOARD

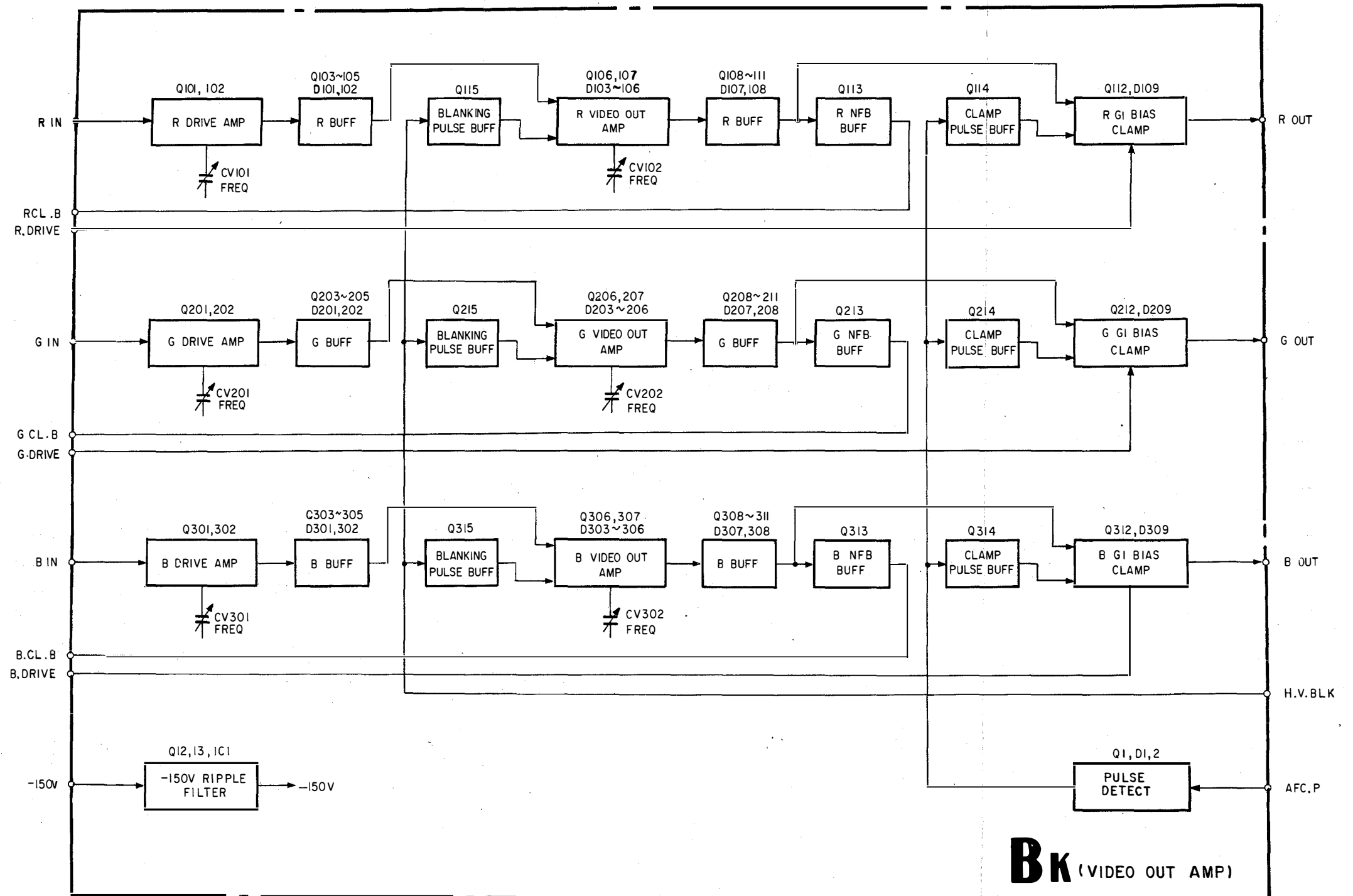

3-7. BEAM CONTROL CIRCUIT (BI, BK BOARDS)

Block diagram is shown in Figure 10.

3-7-1. Detection of Cathode Current and I-V Conversion (BI BOARD)

Cathode current is detected as a voltage by using IC105 (1/2)

3-7-2. Red G1 Bias Control (BI BOARD)

BMP is inserted in the signal during vertical blanking in BI board. This BMP is detected as a cathode current and sampled by BM CLP applied to FET Q113.

This bias control circuit controls the base voltage of transistor Q114 so that converted voltage from cathode current and the reference voltage may match.

3-7-3. Red G1 Bias Clamp Circuit (BK BOARD)

Video output signal is clamped at the voltage of collector of transistor Q114 in BI board by using transistor Q112.

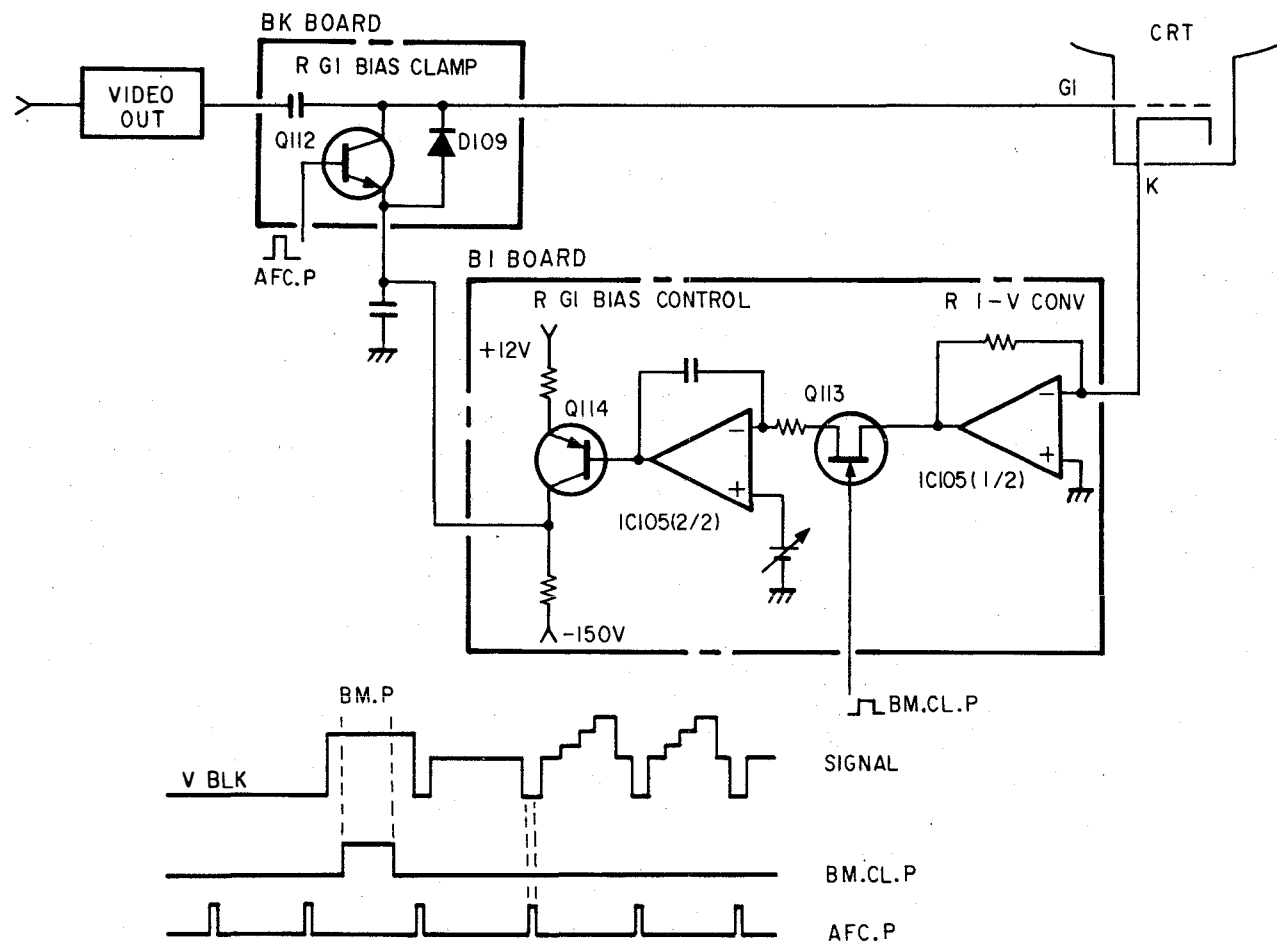

Figure 10

3-8. PAL DEMODULATOR, Y TRAP CIRCUIT (BD BOARD)

The composite video signal (PAL) supplied from BA board is fed to transistor Q1 (buffer), then is supplied to the 4.43 MHz trap circuit with Y signal and to band pass filter with chrominance signal.

3-8-1. Chroma Band Pass Filter

The composite video signal obtained from at the emitter of transistor Q1 is fed to the Band pass filter composed of resistor R12, capacitor C7, C8, inductor L3 and transistor Q5. The center frequency of this filter is adjusted to the subcarrier frequency (4.43 MHz) by L3, and chrominance signal is derived from Q5.

3-8-2. Residual SW Circuit

The chrominance signal derived at transistor Q5 is fed to analog switcher IC2. When switch S1 on BJ board is set to ON position, residual pulse which has almost same phase as H sync is fed to control terminal of analog switcher (pin ③ of IC2) and screening is performed during H sync period. When switch S1 on BJ board is set to OFF position, Low level signal (0V DC) is fed to control terminal and screening action is not performed. Thus residual switch circuit does not activate. When there is residual subcarrier in the video signal, clamp level of color difference signal changes by turning switch S1 ON/OFF and therefore residual subcarrier can be checked on the picture as a color shift.

3-8-3. Chroma Amplifier Circuit

The chrominance signal from residual switch circuit (IC2 pin ④) is fed to chroma amplifier circuit (Q19, Q36). After the chroma signal is amplified by the inversion amplifier (gain: 1X), it is voltage divided by resistors R400 and R314 and then input to the R-Y input terminal (IC1, pin ③) and B-Y input terminal (IC1, pin ②) of the following demodulator circuit via the buffer (Q38).

3-8-4. Phase Control Circuit

The chrominance signal from residual switch is also fed to phase control circuit (Q6, Q7, Q8, Q9, D12). In this circuit, a variable capacitance diode (D10) is used to control the phase of color burst signal. Anode voltage of D10 is applied by variable resistor RV8 and preset adjustment of phase is made by this variable resistor. When the PHASE control on the right side of the front panel is turned, DC level of phase control signal (board terminal A13) changes and this phase control signal is fed to the cathode of D10 via analog switcher (IC5). In this way, Burst phase of chrominance signal is controlled according to the DC level of the phase control signal. When PAL-D is selected with the PAL switch inside the right side drawer, between pins ③ and ④ of IC5 becomes conductive and phase control becomes dependent on RV7, disabling the Phase Control of the right side front panel.

Analog switcher IC5 (1/3) activates to make short-circuit between input terminal pin ③ or ⑤ and output terminal pin ④, only when COLOR STANDARD SELECTOR in the right side of drawer is selected to PAL and otherwise pin ⑤ kept open circuit. As above phase controlled chrominance signal is derived from collector of transistor Q9 and burst signal in this signal is gated by IC6. The gated burst signal is fed to the burst input terminal pin ⑪ of demodulator IC1.

3-8-5. PAL Demodulator

Block diagram of IC used for PAL demodulator is shown in Figure 1. This IC is designed for use of NTSC demodulator. When chrominance signal is fed to pin ② and pin ③, color burst signal to pin ⑪ and Burst Gate Pulse (B.G.P.) to pin ⑬, R-Y and B-Y color difference signals are obtained at output terminals pin ⑬ and pin ⑭. The demodulation axes of this demodulator are R-Y axis and B-Y axis. Variable capacitor CV1 is adjusted so that the phase angles between them are 90°. Local oscillator (4.43 MHz) is formed by CW oscillator in IC1 connected to the terminal pin ⑤, ⑥, ⑦, ⑧ and external circuit. The variable capacitor CV2 is adjusted so that the free run frequency may be subcarrier frequency 4.433619 MHz. Also APC (Automatic Phase Control) circuit is formed by APC section in IC1 connected to the terminal pin ⑨ and ⑩ local oscillator is controlled by APC circuit. The color difference signals demodulated by this IC are fed to low pass filter, where high frequency component is removed, then R-Y and B-Y color difference signals are obtained.

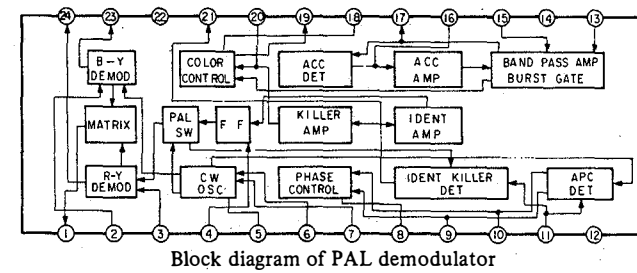

Figure 1

3-8-6. PAL-D Matrix and PAL S/D Switching Circuit

This circuit is further divided into circuits for the R-Y and B-Y signals, but the operation of both circuits is the same. So only the R-Y one will be explained. R-Y signals input from the demodulator circuit are input to Q20 (BUFF) and Q21 (BUFF). The signals input to Q21 are then input to pin ② of the analog switcher (IC5). When PAL S has been selected, between pins ② and ⑬ becomes conductive and the signals are supplied to the following circuit via Q33 (BUFF). The signals input to Q20 are formed by IC7 and Q18. Bias is controlled by a clamp circuit and is input to pin ⑮ of the 1H delay line (IC3). The DC level of the input is adjusted to the optimum value by using RV9. IC3, driven by the 10.64 MHz clock signal generated by the clock generator circuit configured with XZ, Q34 and Q35, delays the input signal by 1H cycle and outputs it from pin ⑪.

The high frequency component of the signal thus output is removed by the low-pass filter configured with Q22 and Q23, after which the signal is input to the following PAL-D matrix circuit. The PAL-D matrix circuit is configured with R100, R101 and Q24. The signal that was not delayed is input through R100 while the 1H delayed signal is input through R101 at a ratio of 1/2. The PAL-D signal added to the base of Q24 is obtained from its emitter. The signal obtained from the Q24 emitter is input to pin ① of IC5. When PAL-D is selected, between pins ① and ⑬ becomes conductive and the signal is supplied to the following circuit via Q33 (BUFF).

3-8-7. 4.43 MHz Trap Circuit, Phase Compensation, Y Delay Correction Circuit

The composite video signal from the emitter of transistor Q1 is fed to 4.43 MHz trap circuit composed of resistor R5, R6, R7, capacitor C1, C2 and inductor L1. Adjustment of L1 is made so that the resonance frequency of this trap circuit should be subcarrier frequency. Y (Luminance) signal removed subcarrier is obtained at output terminal of the trap circuit and is fed to the phase compensation circuit. (Transistor Q2, resistor R8, R9 R10, inductor L2 capacitor C4) This circuit compensates phase delay of the signal at high frequency due to the trap circuit. Y signal compensated phase delay is fed to Y-delay-circuit. In this circuit Luminance/Chrominance time error is compensated by delay line.

3-8-8. Color Standard Selector

When PAL system is not selected by the COLOR STANDARD SELECTOR in the right side drawer, transistor Q101, Q102 are cut off and ±12V line power source is not supplied to the demodulator circuit.

BLOCK DIAGRAM OF BD (PAL) BOARD

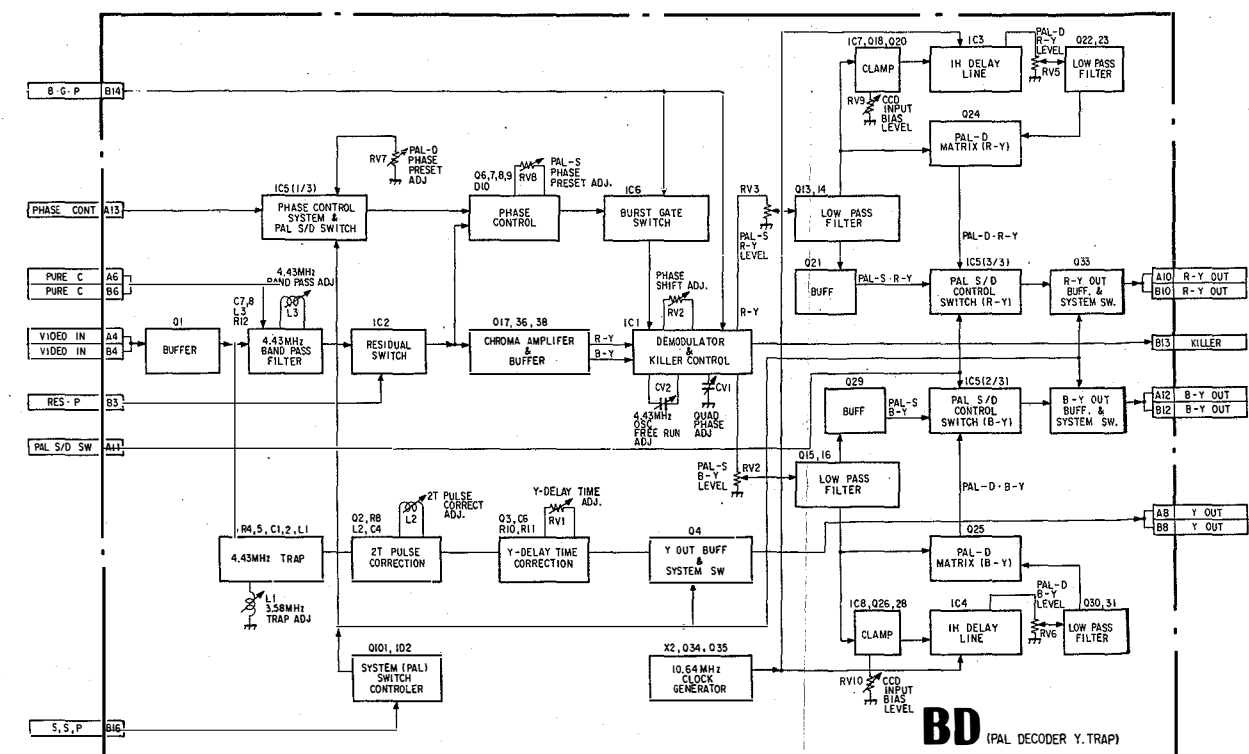

3-9. PAL-M DEMODULATOR, Y TRAP CIRCUIT (BM BOARD)

The composite video signal supplied from BA board is fed to transistor Q1 (buffer), then is supplied to the 3.58 MHz trap circuit with Y signal and to band pass filter with chrominance signal.

3-9-1. Chroma Band Pass Filter

The composite video signal obtained from at the emitter of transistor Q1 is fed to the Band pass filter composed of resistor R12, capacitor C7, C8, inductor L3 and transistor Q5.

The center frequency of this filter is adjusted to the subcarrier frequency (3.58 MHz) by L3, and chrominance signal is derived from Q5.

3-9-2. Residual SW Circuit

The chrominance signal derived at transistor Q5 is fed to analog switcher IC2.

When switch S1 on BJ board is set to ON position, residual pulse which has almost same phase as H sync is fed to control terminal of analog switcher (pin ③ of IC2) and screening is performed during H sync period.

When switch S1 on BJ board is set to OFF position, Low level signal (0V DC) is fed to control terminal and screening action is not performed. Thus residual switch circuit does not activate.

When there is residual subcarrier in the video signal, clamp level of color difference signal changes by turning switch S1 ON/OFF and therefore residual subcarrier can be checked on the picture as a color shift.

3-9-3. Chroma Amplifier Circuit

The chrominance signal from residual switch circuit (IC2 pin ④) is fed to chroma amplifier circuit (Q19, Q36).

After the chroma signal is amplified by the inversion amplifier (gain: 1X), it is voltage divided by resistors R400 and R314 and then input to the R-Y input terminal (IC1, pin ③) and B-Y input terminal (IC1, pin ②) of the following demodulator circuit via the buffer (Q38).

3-9-4. Phase Control Circuit

The chrominance signal from residual switch is also fed to phase control circuit (Q6, Q7, Q8, Q9, D12).

In this circuit, a variable capacitance diode (D10) is used to control the phase of color burst signal.

Anode voltage of D10 is applied by variable resistor RV8 and preset adjustment of phase is made by this variable resistor.

When the PHASE control on the right side of the front panel is turned, DC level of phase control signal (board terminal A13) changes and this phase control signal is fed to the cathode of D10 via analog switcher (IC5). In this way, Burst phase of chrominance signal is controlled according to the DC level of the phase control signal.

When PAL-D is selected with the PAL switch inside the right side drawer, between pins ③ and ④ of IC5 becomes conductive and phase control becomes dependent on RV7, disabling the Phase Control of the right side front panel.

Analog switcher IC5 (1/3) activates to make short-circuit between input terminal pin ③ or ⑤ and output terminal pin ④, only when COLOR STANDARD SELECTOR in the right side of drawer is selected to PAL and otherwise pin ⑤ kept open circuit. As above phase controlled chrominance signal is derived from collector of transistor Q9 and burst signal in this signal is gated by IC6. The gated burst signal is fed to the burst input terminal pin ⑪ of demodulator IC1.

3-9-5. PAL-M Demodulator

Block diagram of IC used for PAL demodulator is shown in Figure 1. This IC is designed for use of NTSC demodulator.

When chrominance signal is fed to pin ② and pin ③, color burst signal to pin ⑪ and Burst Gate Pulse (B.G.P.) to pin ⑬, R-Y and B-Y color difference signals are obtained at output terminals pin ⑫ and pin ⑭.

The demodulation axes of this demodulator are R-Y axis and B-Y axis. Variable capacitor CV1 is adjusted so that the phase angles between them are 90°.

Local oscillator (3.58 MHz) is formed by CW oscillator in IC1 connected to the terminal pin ⑤, ⑥, ⑦, ⑧ and external circuit.

The variable capacitor CV2 is adjusted so that the free run frequency may be subcarrier frequency 3.575611 MHz.

Also APC (Automatic Phase Control) circuit is formed by APC section in IC1 connected to the terminal pin ⑨ and ⑩ local oscillator is controlled by APC circuit.

The color difference signals demodulated by this IC are fed to low pass filter, where high frequency component is removed, then R-Y and B-Y color difference signals are obtained.

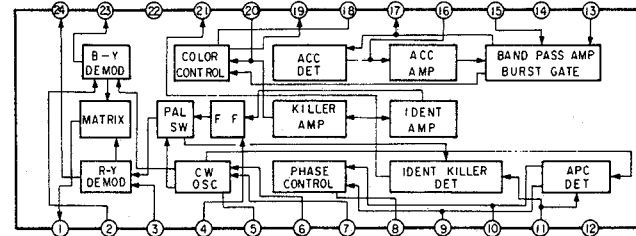

Block diagram of PAL-M demodulator

Figure 1

3-9-6. PAL-D Matrix and PAL S/D Switching Circuit

This circuit is further divided into circuits for the R-Y and B-Y signals, but the operation of both circuits is the same. So only the R-Y one will be explained.

R-Y signals input from the demodulator circuit are input to Q20 (BUFF) and Q21 (BUFF).

The signals input to Q20 are then input to pin ② of the analog switcher (IC5). When PAL S has been selected, between pins ② and ⑤ becomes conductive and the signals are supplied to the following circuit via Q33 (BUFF).

The signals input to Q20 are formed by IC7 and Q18. Bias is controlled by a clamp circuit and is input to pin ⑮ of the 1H delay line (IC3). The DC level of the input is adjusted to the optimum value by using RV9.

IC3, driven by the 10.64 MHz clock signal generated by the clock generator circuit configured with XZ, Q34 and Q35, delays the input signal by 1H cycle and outputs it from pin ⑪.

The high frequency component of the signal thus output is removed by the low-pass filter configured with Q22 and Q23, after which the signal is input to the following PAL-D matrix circuit.

The PAL-D matrix circuit is configured with R100, R101 and Q24. The signal that was not delayed is input through R100 while the 1H delayed signal is input through R101 at a ratio of 1/2.

The PAL-D signal added to the base of Q24 is obtained from its emitter. The signal obtained from the Q24 emitter is input to pin ① of IC5. When PAL-D is selected, between pins ① and ③ becomes conductive and the signal is supplied to the following circuit via Q33 (BUFF).

3-9-7. 3.58 MHz Trap Circuit, Phase Compensation, Y Delay Correction Circuit

The composite video signal from the emitter of transistor Q1 is fed to 3.58 MHz trap circuit composed of resistor R5, R6, R7, capacitor C1, C2 and inductor L1.

Adjustment of L1 is made so that the resonance frequency of this trap circuit should be subcarrier frequency.

Y (Luminance) signal removed subcarrier is obtained at output terminal of the trap circuit and is fed to the phase compensation circuit. (Transistor Q2, resistor R8, R9, R10, inductor L2 capacitor C4)

This circuit compensates phase delay of the signal at high frequency due to the trap circuit.

Y signal compensated phase delay is fed to Y-delay circuit. In this circuit Luminance/Chrominance time error is compensated by delay line.

3-9-8. Color Standard Selector

When PAL system is not selected by the COLOR STANDARD SELECTOR in the right side drawer, transistor Q101, Q102 are cut off and ±12V line power source is not supplied to the demodulator circuit.

BLOCK DIAGRAM OF BM (PAL-M) BOARD

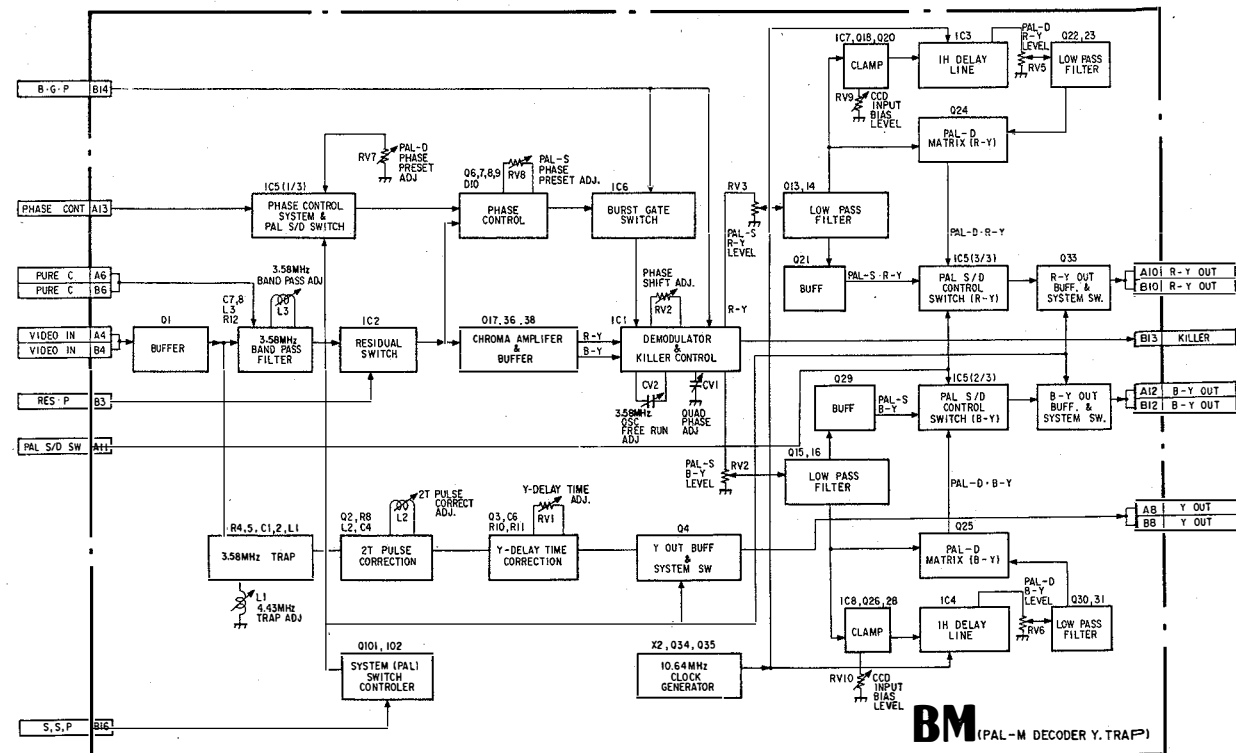

**3-10. VERTICAL DEFLECTION OUTPUT CIRCUIT
CONVERGENCE OUTPUT CIRCUIT
(EB BOARD)**

3-10-1. Vertical Deflection Output

Vertical Deflection Output amplifier is composed of DC coupled SEPP amplifier (Single Ended Push Pull) and boost up circuit. This boost up circuit contains transistors Q7 and Q8 to reduce power consumption by applying the voltage to the output transistor during vertical retrace time.

Both vertical rate saw tooth waveform and correction waveform for top and bottom pincushion are generated in DA board and fed to output amplifier. Vertical centering is performed by changing DC level of vertical rate sawtooth because Vertical DY (Deflection Yoke) is connected to output amplifier directly.

3-10-2. Convergence Yoke Output Circuit

CY (Convergence Yoke) is used for adjustment of misconvergence of vertical direction. This CY is driven by SEPP (single ended push pull) amplifier and connected directly. Correction waveform is provided from DB board.

**3-10-3. HCT (Horizontal Convergence Transformer)
Output Circuit**

This circuit is used for adjustment of misconvergence for Horizontal direction.

HCT is also driven by SEPP amplifier and AC coupled to it. Correction waveform is provided to the primary of HCT and transferred to the secondary windings, output voltage of secondary windings is applied to CV electrode of CRT (picture tube) and performed convergence adjustment.

circuit diagram shown in Figure 16 is the theory of basic HCT circuit.

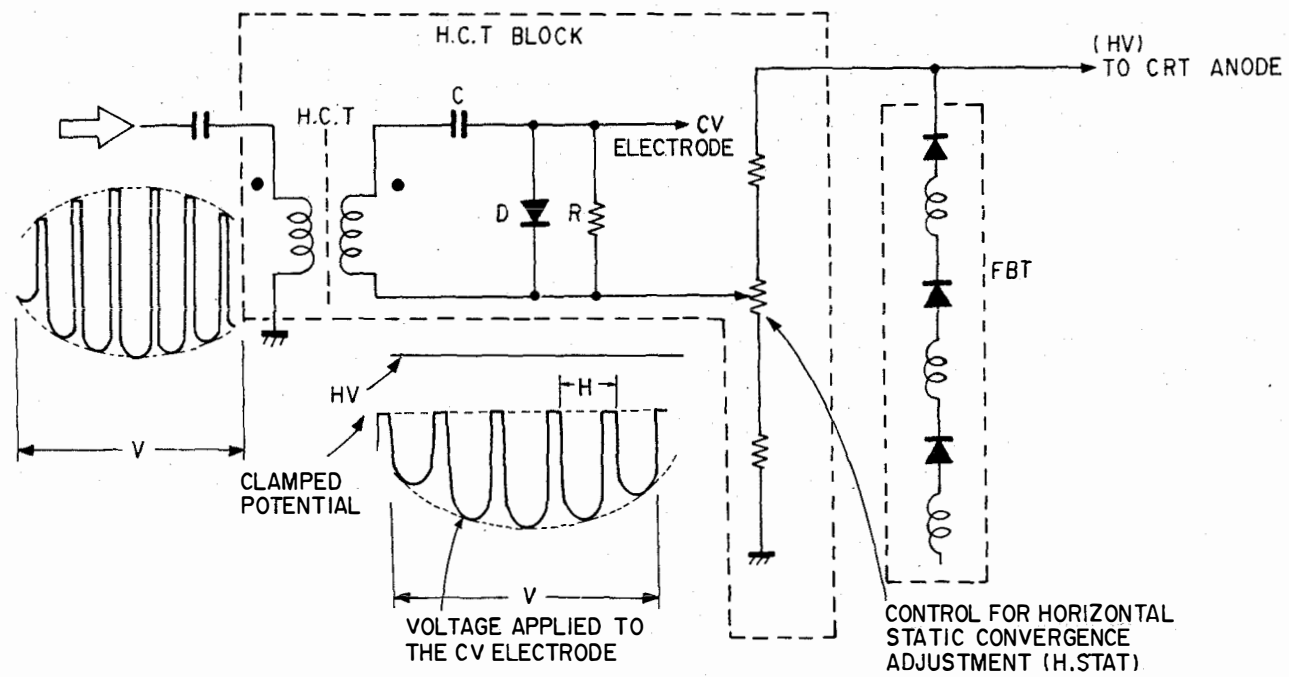
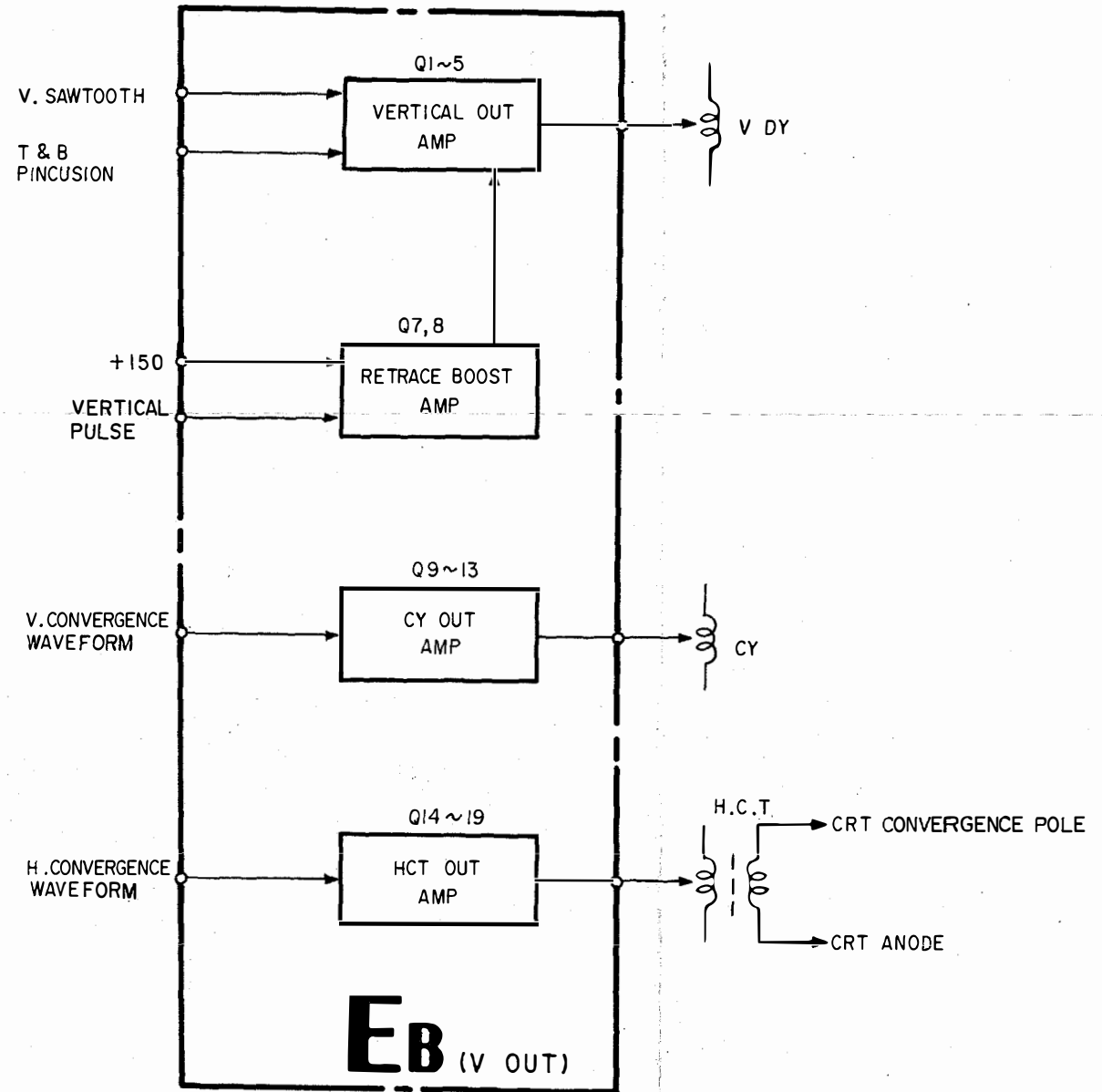

Figure 16

BLOCK DIAGRAM OF EB BOARD



3-11. POWER SUPPLY CIRCUIT (GA, GB BOARDS)

3-11-1. AC Power Supply, Rectifier Circuit

Voltage selector located at the rear side of the unit should be selected to the local line voltage (AC 100/120V or 220/240V). In case of AC 100/120V selected by voltage selector, rectifier D21 capacitors C80 and C81 operate as a double multiple rectifier. See Figure 17(a). In case of AC 220/240V selected by voltage selector, rectifier D21 capacitors C80 and C81 operate as a full-wave rectifier. See Figure 17(b).

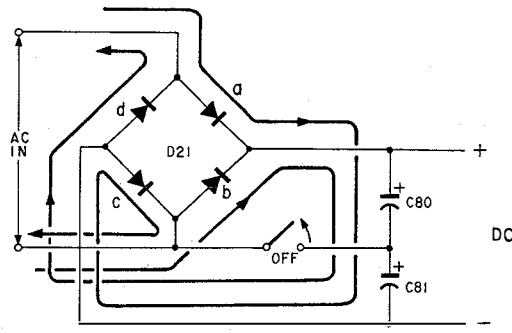
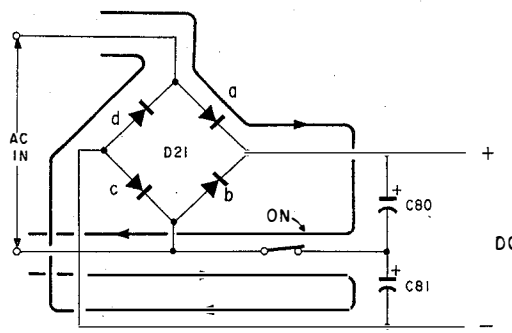

Figure 17(a)



AC IN Passes through D21d and charges to C81.
AC Passes through D21a and charges to C80.

Figure 17(b)

3-11-2. Degauss Circuit

There are 2 pistors (PTH1, PTH2) in the degaussing circuit. One is used for AC 100/120V operation, the other is for AC 220/240V operation, these pistors are switched by voltage selector. This degaussing circuit is turned ON and OFF by using Relay (RY1) automatically. When power is turned ON, Automatic degaussing starts to work and a few seconds later stops automatically. Also Manual degaussing is available if necessary after a few minutes power is turned on when pistors (PTH1 or PTH2) gets cool down. This manual degaussing is operated by a push of button (Degauss Switch) at the left of the front panel. When degaussing circuit starts to work, Q11 transistor turns on by time constant circuit composed of resistors R88, 91 and capacitor C74. Q11 drives Q12 transistor. Relay (RY1) is driven by Q12. Time constant circuit keeps degaussing circuit to activate for several seconds until degaussing is finished.

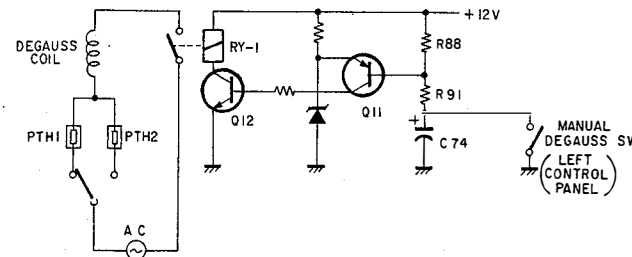

Figure 18

3-11-3. Starter Circuit

Blocking oscillator composed of integrated circuit IC1 and transformer T4 operates when power is turned on. DC voltage obtained by diode D7 and capacitor C57 as a rectifier at the secondary circuit of T4 is supplied to IC2 and IC3, when AC voltage is higher than 50 ~ 70V (voltage selector at 100/120V position). Then power supply regulator starts to work and +15V line power supply is provided to IC2 and IC3 via diode D20, also voltage from T4 stops providing power supply to IC2 and IC3 because blocking oscillator is shut down by voltage generated at primary windings of SRT (Switching Regulator Transformer).

3-11-4. Switching Regulator Circuit

Block diagram is shown in Figure 19. This is half bridge type of switching regulator in this model.

Following Description is the Theory of Half-Bridge Switching Regulator.

DC voltage E_{IN} rectified from AC voltage in AC power rectifier section is divided by capacitor C1 and C2. C1 and C2 have almost same value. Q1 (contains 2 transistors) operates as a switch driven by PWM modulated pulse via T2 (Drive Transformer). Switching current flows through primary windings of T1 (SRT) by switching transistor Q1 via T3 (Current Transformer). Thus output voltages are generated at secondary windings of T1.

Practical Circuit Used in this Model

There are 2 switching regulators in this power supply. One is for low voltage power supply, $\pm 15V$, $\pm 18V$ and $+5V$. The other is for high voltage $\pm 150V$ power supply. Low voltages are generated by IC2, T1, T2, T3 and Q2. High voltages are generated by IC3, T6, T7 and Q2. Refer to block diagram. Current Transformer T3 and T7 detects excess current in transistor Q1 and Q2 for the protection of damage.

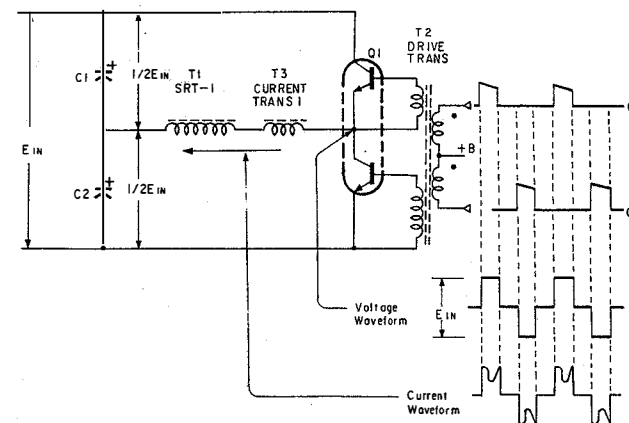
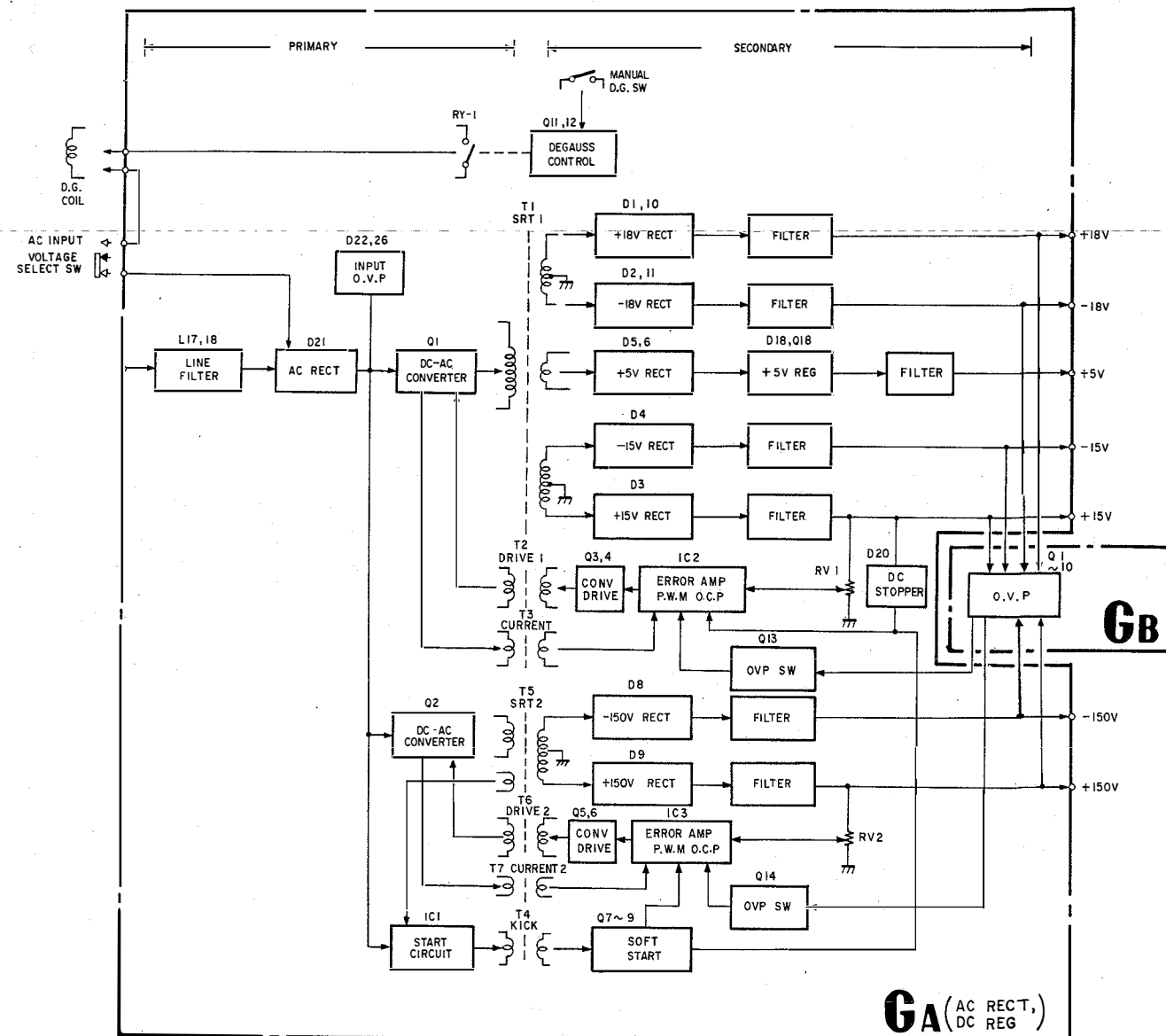

Figure 19

3-11-5. Over Voltage Protector

Daughter board GB is mounted in mother board GA. GB board works for over voltage protection. When output voltage gets higher value than predetermined value, over voltage protector activates to prevent damage of unit.

BLOCK DIAGRAM OF GA, GB BOARD



3-12. CONVERGENCE CIRCUIT (DB, EB BOARD, HCT BLOCK)

3-12-1. General Description

This is a simple explanation of the convergence system in Super fine Trinitron picture tube used in this model. The Deflection Yoke (DY) used in this model generates an almost uniform magnetic field in order to get fine beam spot size. Accordingly basically misconvergence of horizontal direction as shown in Figure 20 is generated on the picture screen.

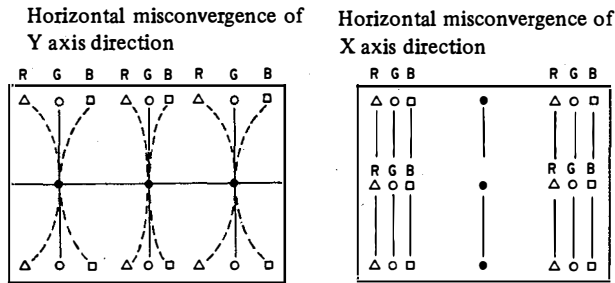

Figure 20

3-12-2. Static Electrical Convergence System

Trinitron system has a unique static convergence system. The structure of electric gun is shown in Figure 21. G6 is the electrode for convergence. Static electrical convergence control can be used. In this system beam spot deterioration is less than that of the electromagnetic system.

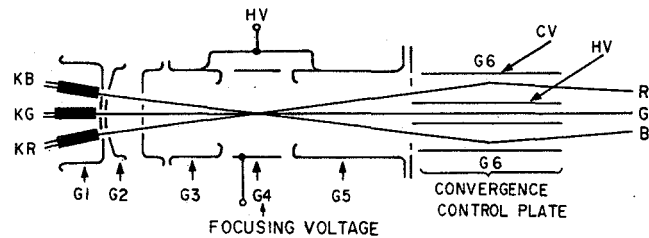

Figure 21

3-12-3. Convergence Correction Circuit (Horizontal Convergence)

Misconvergence of horizontal direction on Y axis is corrected by applying vertical rate parabola waveform to the convergence plate (G6). And misconvergence of horizontal direction is corrected by applying horizontal rate parabola waveform to G6. See Figure 22.

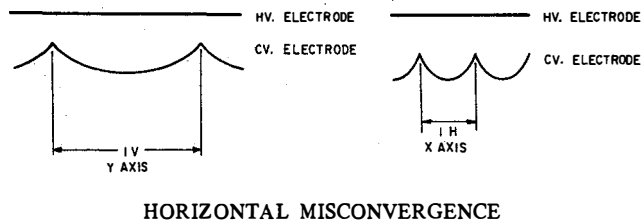

Figure 22

In this model, transformer is used to supply correction voltage to the G6 electrode for the horizontal direction misconvergence. In the secondary of the transformer peak clamp circuit using diode is applied so that both the vertical rate parabola waveform and horizontal rate parabola waveform are mixed and supplied to CV electrode. See Figure 23.

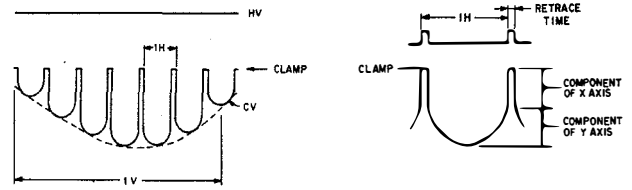

Figure 23

The correction waveforms are generated in DB board and output amplifier is located in EB board.

3-12-4. Vertical Convergence

Theoretically there is no misconvergence of Vertical direction since electric gun is aligned in line. But there is a slight amount of misconvergence due to the variations of CRT and DY and also due to the terrestrial magnetism.

There are also 2 kinds of misconvergence of vertical direction on X axis and Y axis as same as horizontal direction.

Misconvergence of Vertical direction on X axis is corrected by CY (convergence yoke).

Figure 24 shows the CRT neck as seen from the rear side.

Red beam and Blue beam are moved to the vertical direction differentially by CY. As Green beam is at the center of the CRT neck, it is not affected by the magnetic field of CY due to the cancellation of the magnetic field at the center of the neck.

Misconvergence of vertical direction on Y axis is corrected by NTC (Neck Twist Coil).

A Neck Twist Coil is wound around the center of electrode G2 ~ G3 (See Figure 24) for the correction. Theoretically, as the RED and Blue beams have HI component (They are opposite direction) as seen in Figure 24, they move to the vertical direction due to the magnetic field generated by NTC.

However as magnetic field of the NTC is the parallel to the Green beam, Green beam is not affected.

Correction waveform generator is located in DB board, output amplifier of CY is in EB board and output amplifier of NTC is in DB board.

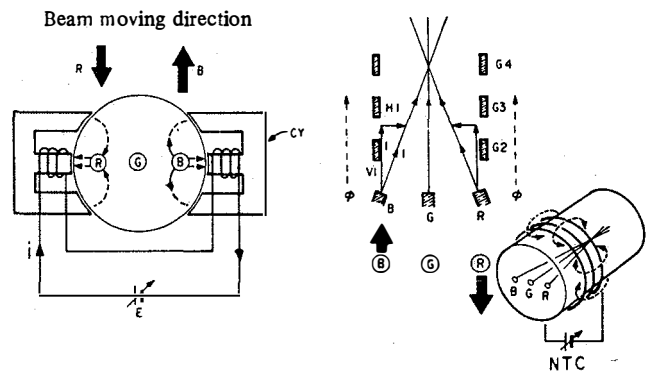
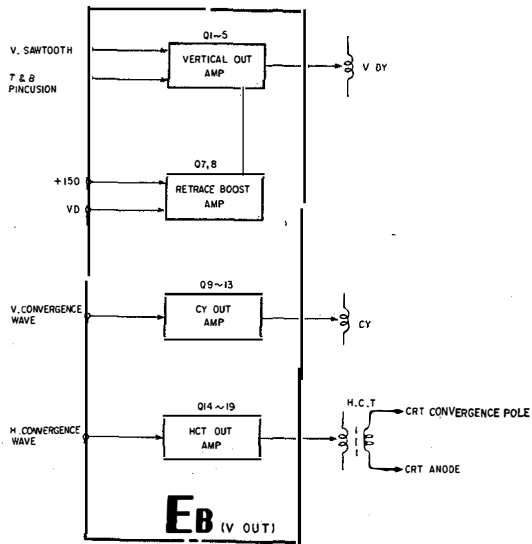
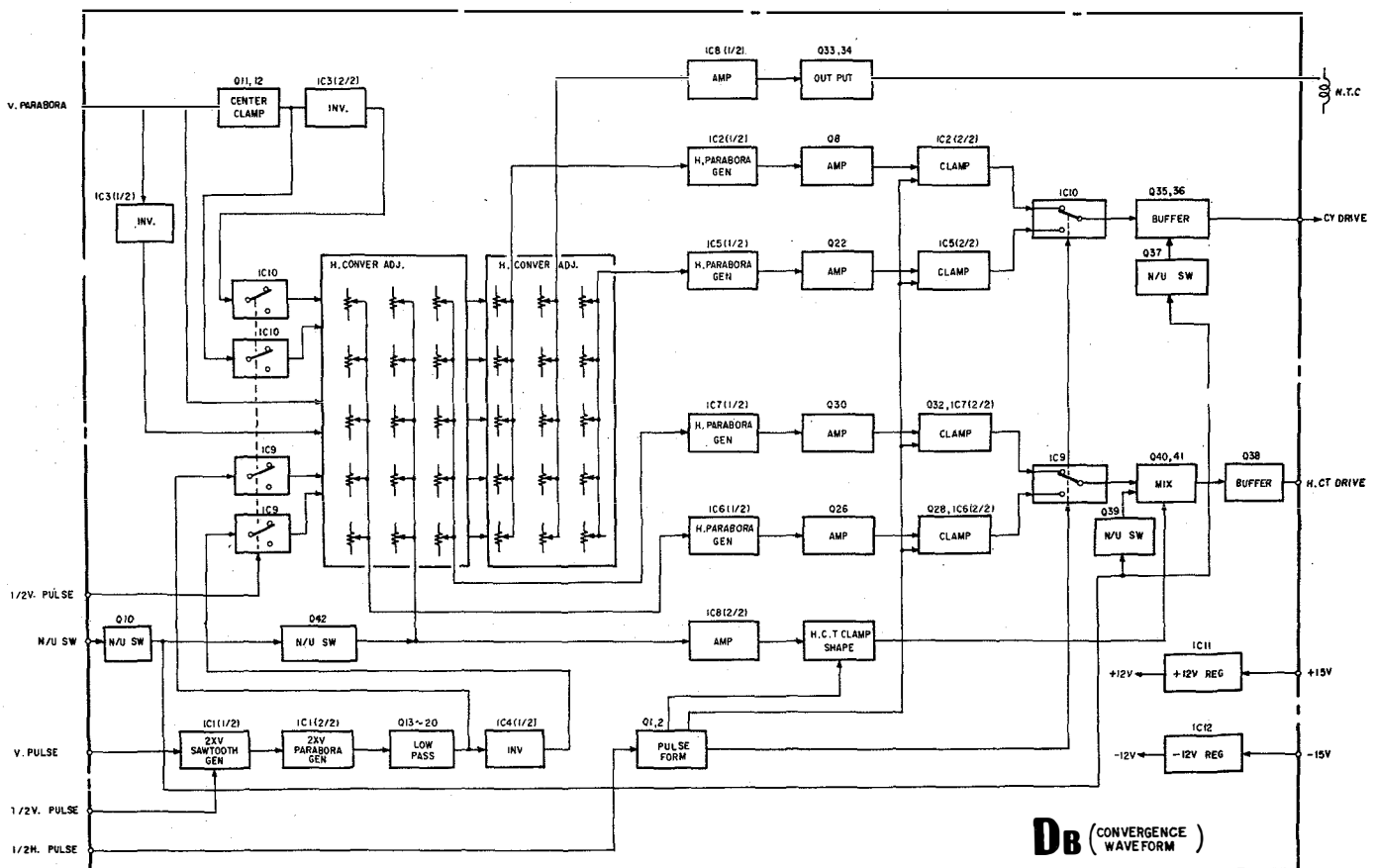

Figure 24

BLOCK DIAGRAM OF EB BOARD



BLOCK DIAGRAM OF DB BOARD



3-12-5. Convergence Correction Waveform Generator (DB BOARD)

This monitor incorporates unique convergence circuit which can adjust convergence at 15 positions of the picture screen, each 15 potentiometers for horizontal and vertical convergence adjustments are located on the left side of the drawer corresponding to the picture screen.

3-12-6. Horizontal Convergence Correction Waveform Generator

A vertical rate parabola waveform is supplied to the DB board from the DB board and is inverted and switched to make correction waveform.

For the left side of the picture screen, the correction waveform is compounded by adjusting potentiometers RV16 ~ RV20. This waveform is converted to horizontal rate parabola waveform which level is proportional to the compounded waveform by H parabola generator (IC6, Q25). This is amplified by transistor Q26 and clamped at the center position of the horizontal period by transistor Q28 and IC6. See Figure 25.

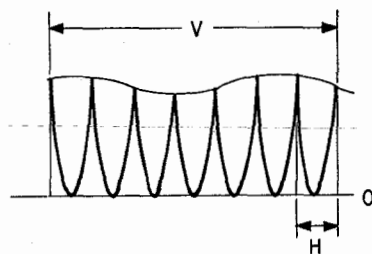

Figure 25

For the right side of the picture screen, the correction waveform is generated by adjusting potentiometers RV26 ~ RV30 as same as the left side of the picture.

These correction waveforms (left and right side) are switched and mixed by analog switcher which activates at 1/2H period as seen in Figure 26.

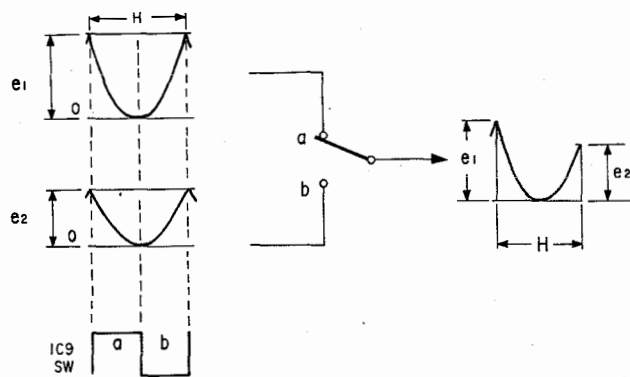

Figure 26

As a result, right side adjustments and left side adjustment can be performed independently of each other.

For the center of the picture screen, vertical parabola waveform is compounded to the correction waveform by adjusting potentiometers RV21 ~ 25, and converted to horizontal pulse. This means amplitude of horizontal pulse is modulated by vertical parabola.

This modulated pulse is mixed with horizontal parabola for left and right side correction. This mixed waveform is amplified and supplied to convergence plate in CRT via HCT. Thus horizontal convergence is corrected. See Figure 27.

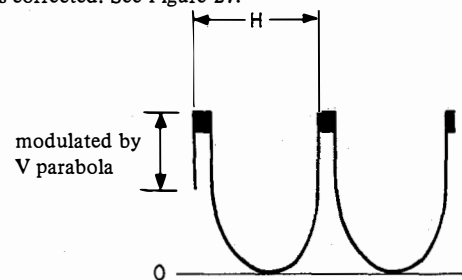

Figure 27

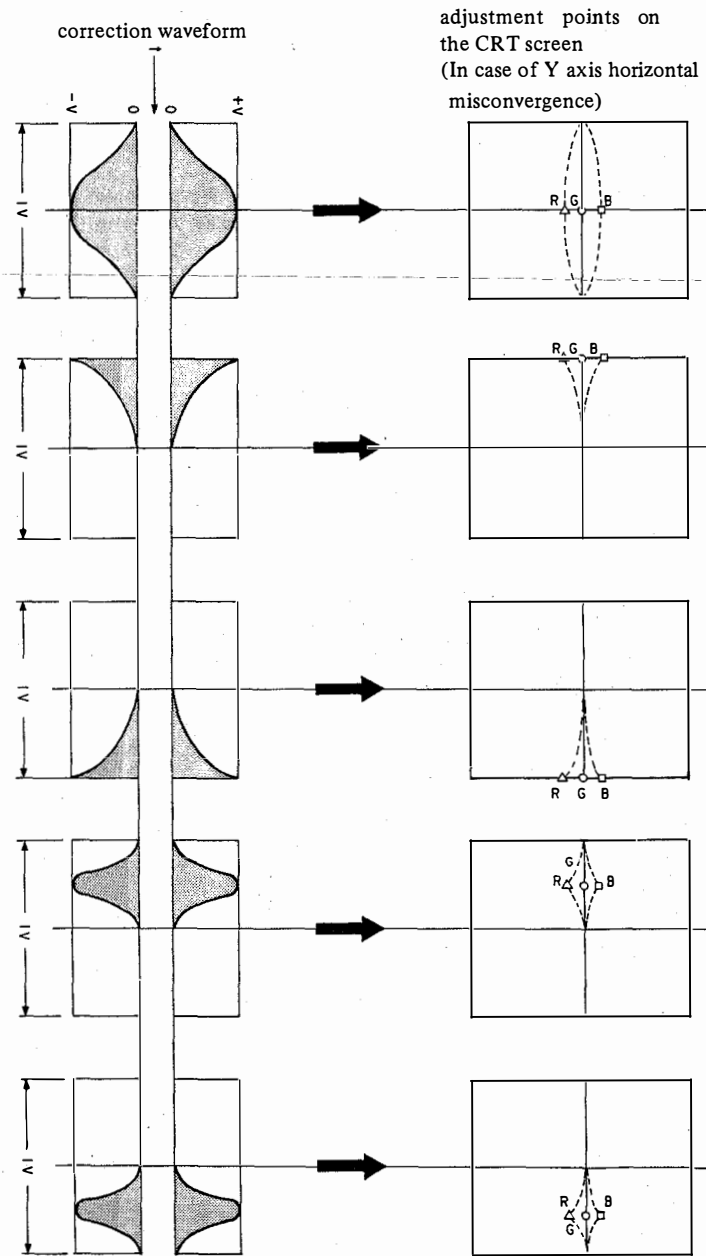

Figure 28

3-12-7. Vertical Convergence Correction Waveform Generator

For the left and right side of the picture, correction circuit for vertical convergence is same as horizontal correction circuit of left and right side of the picture. The correction waveform is amplified in EB board and supplied to CY.

For the center of picture screen, correction waveform is fed to amplifier (IC8 (1/2), Q33 Q34) and supplied to NTC (Neck twist Coil).

This vertical convergence is performed.

Diagram of correction waveform generation

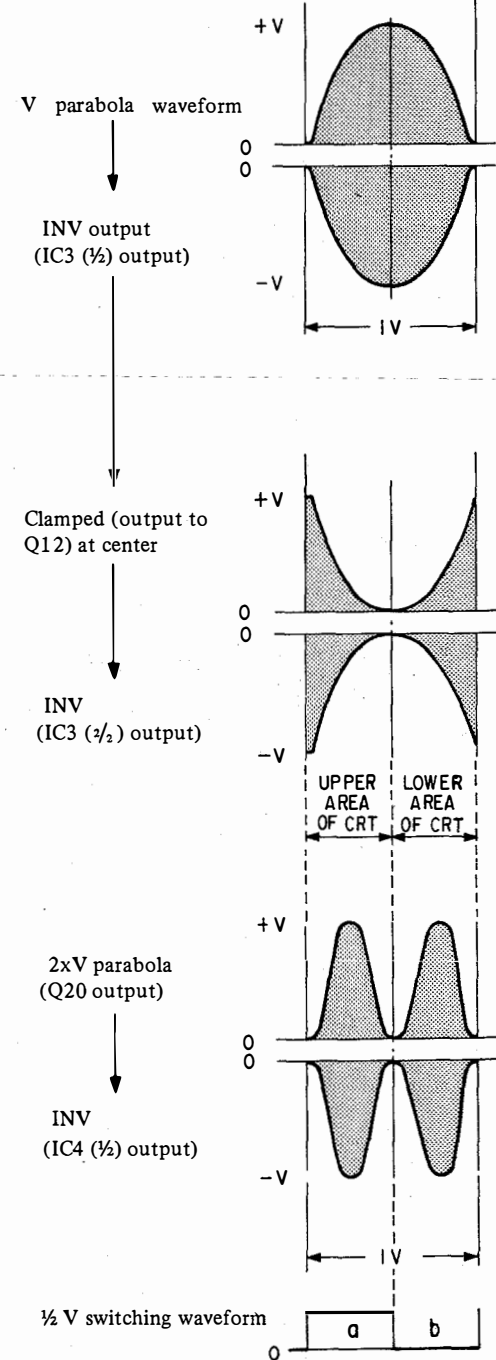
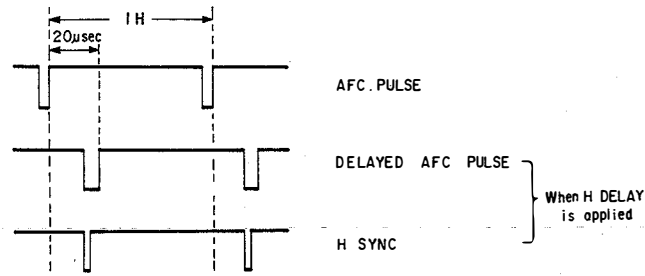

Figure 29

3-13. DEFLECTION CIRCUIT (DA BOARD)

3-13-1. H Delay and Horizontal AFC (Automatic Frequency Control) Circuit

In this model H delay function is performed by delaying H. AFC pulse in the horizontal AFC circuit. (See Figure 30)
H. AFC pulse which is fed from H.O.T. (Horizontal Output transformer) is wave shaped and is delayed about 20 μ s by IC1 (2/2). This delayed pulse is integrated by inductor L1, and capacitor C14, thus saw tooth waveform is obtained and fed to terminal pin ④ of IC4. AFC detection is performed by IC4, Output of AFC detector is fed to control terminal of horizontal oscillator (H.OSC) via low pass filter composed of capacitor C12, C15 and resistor R10. 3 types of AFC mode are selected by changing low pass filter which determines AFC time constant. AFC time constant circuit is composed of switch S1, resistor R13, R14, R15 and capacitor C17, C18.



Pulse at H delay operation **Figure 30**

3-13-2. Horizontal Linearity Correction Circuit

In this model Horizontal Linearity correction is made by applying correction voltage to the Horizontal deflection circuit. Basically, Linearity correction is made by modulating power source of horizontal output circuit with horizontal saw tooth voltage. Also So-called "Inside pincushion" correction is performed by applying correction waveform to S correction capacitor. This correction waveform is generated by balanced modulator (IC7) with vertical rate parabola waveform. See Figure 31. Horizontal sawtooth waveform is generated by IC5 (1/2) for horizontal linearity correction. Horizontal rate parabola waveform is generated by integration of saw tooth by IC6 (1/2). This parabola waveform is performed balanced modulation by IC7 with vertical rate parabola waveform, horizontal saw tooth and parabola waveform are fed to horizontal linearity output amplifier in EA board. Correction of horizontal linearity correction and inside pincushion correction are performed.

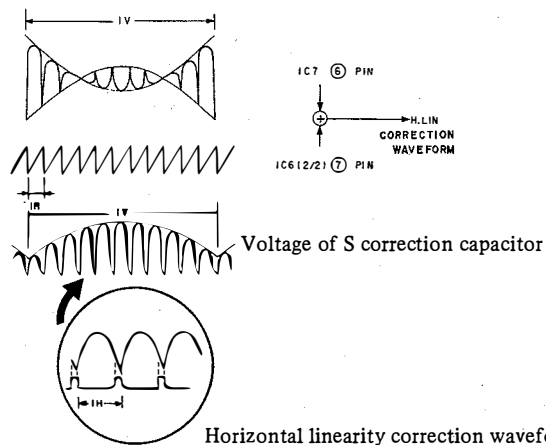

Horizontal linearity correction waveform **Figure 31**

3-13-3. Horizontal Blanking Pulse Generator

Horizontal rate sawtooth waveform generated in H. Linearity circuit is fed to the comparator IC8 (1/2). In this circuit, 1/2H delayed pulse is obtained. This pulse is fed to integrator IC9 (1/2) and 1/2H delayed sawtooth waveform is obtained and this is fed to the comparator IC10 (1/2). Thus the comparator generates horizontal pulse to make H. Blanking pulse which starts just before the starting edge of the retrace time. Also width of horizontal blanking pulse is determined by JK-FF IC1 (1/2).

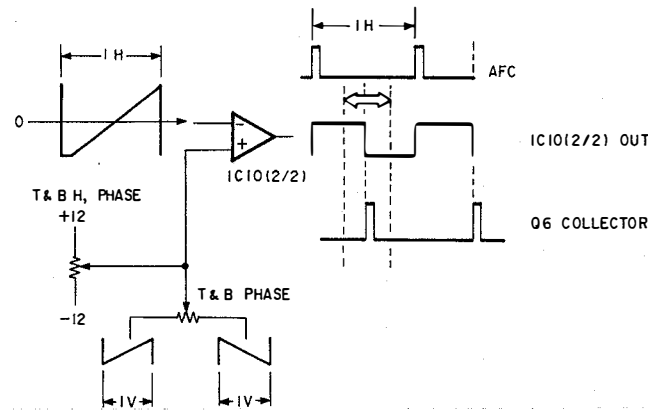

Figure 32

3-13-4. Top & Bottom Pincushion Circuit

Horizontal rate sawtooth waveform generated in H Linearity circuit is also fed IC10. IC10 generates advanced H pulse for the phase correction because vertical Deflection Yoke works as an integrator at horizontal rate, and deflection current for Top & Bottom pincushion correction is delayed about 1/2H for this reason. See Figure 32.

Advanced H pulse is fed to IC11 (1/2) and advanced horizontal sawtooth waveform is generated. It is integrated by IC11 (2/2) and horizontal rate parabola waveform is obtained. Modulated butterfly waveform for Top & Bottom pincushion correction is obtained by Balanced modulator IC2. In this balanced modulator, horizontal rate parabola waveform is used as a carrier and vertical rate sawtooth waveform is modulated by this carrier. See Figure 33. This correction waveform is fed to vertical deflection output amplifier in EB board.

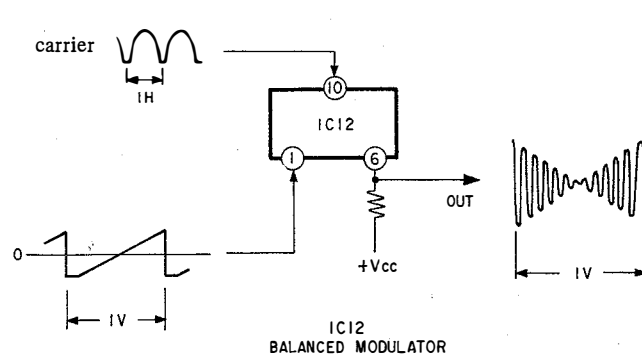

Figure 33

3-13-5. Automatic 50/60Hz Field Selection Circuit

This model has an automatic vertical field frequency selection circuit so that color systems with different frequencies such as NTSC or PAL and SECAM can be received. IC18 is automatic field frequency detecting device and its output switches time constant of integrator in vertical deflection circuit.

3-13-6. Scan Mode Selection Circuit

There are 3 modes of scanning in this model: NORMAL SCAN/ UNDER SCAN/SET UP SCAN. There are level adjustments for H1 width, V, height side pincushion and top & bottom pincushion. Levels of correction waveforms are switched so that these adjustments are made independently for each scanning mode. IC14, IC15 and IC16 activates for this purpose.

3-13-7. Vertical Deflection, Side Pincushion Correction

IC19 (1/2) generates vertical rate sawtooth waveform for vertical deflection. V sawtooth waveform is generated by the integrator IC9 (1/2) which is reset by V sync. Also vertical rate parabola is generated by integrating V. sawtooth waveform by IC9 (2/2). This V parabola is used for side pincushion correction, and also V. parabola is converted to sine waveform by IC20 (1/2) and is mixed with V parabola waveform. This mixed waveform is used for side pincushion correction and fed to side pincushion output amplifier in EA board. Vertical drive voltage for vertical deflection is generated by mixing vertical rate sawtooth waveform generated by IC19 (1/2) and sine waveform generated by IC22 (1/2). This drive waveform is fed to vertical deflection output amplifier. Balance adjustment of vertical linearity correction can be performed by IC22 (1/2) and vertical centering can be adjusted by IC22 (2/2).

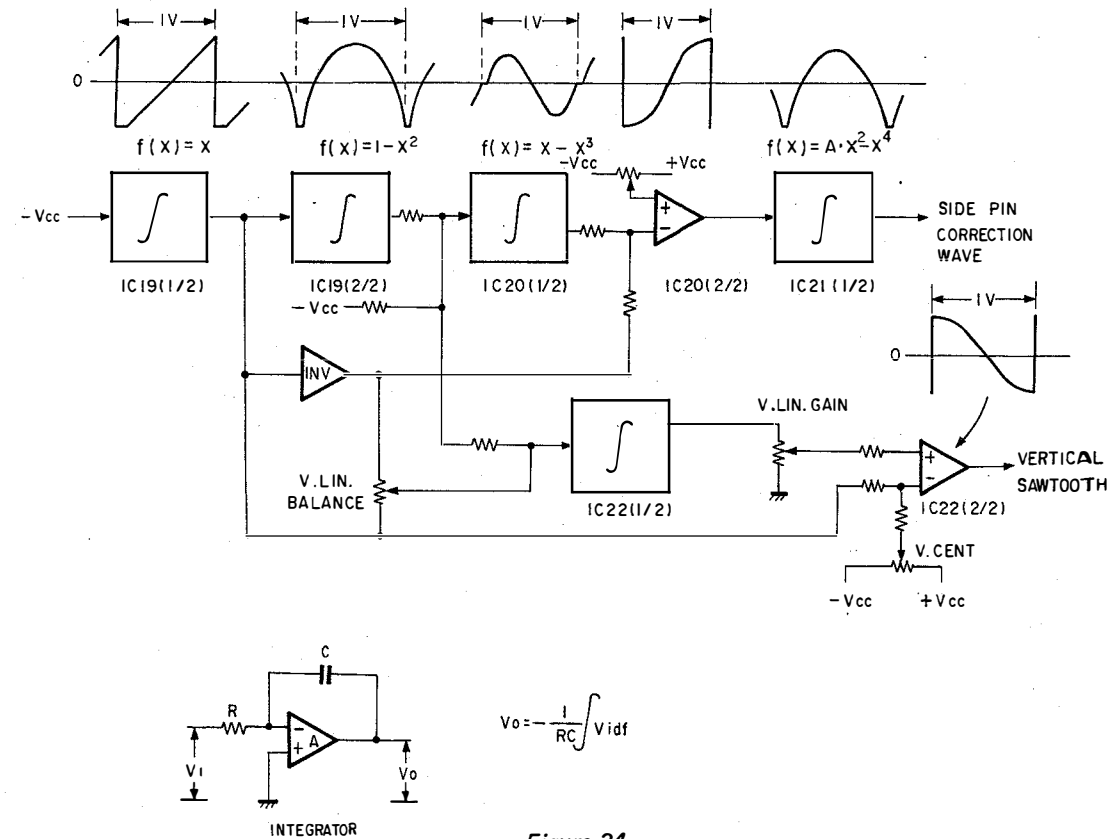
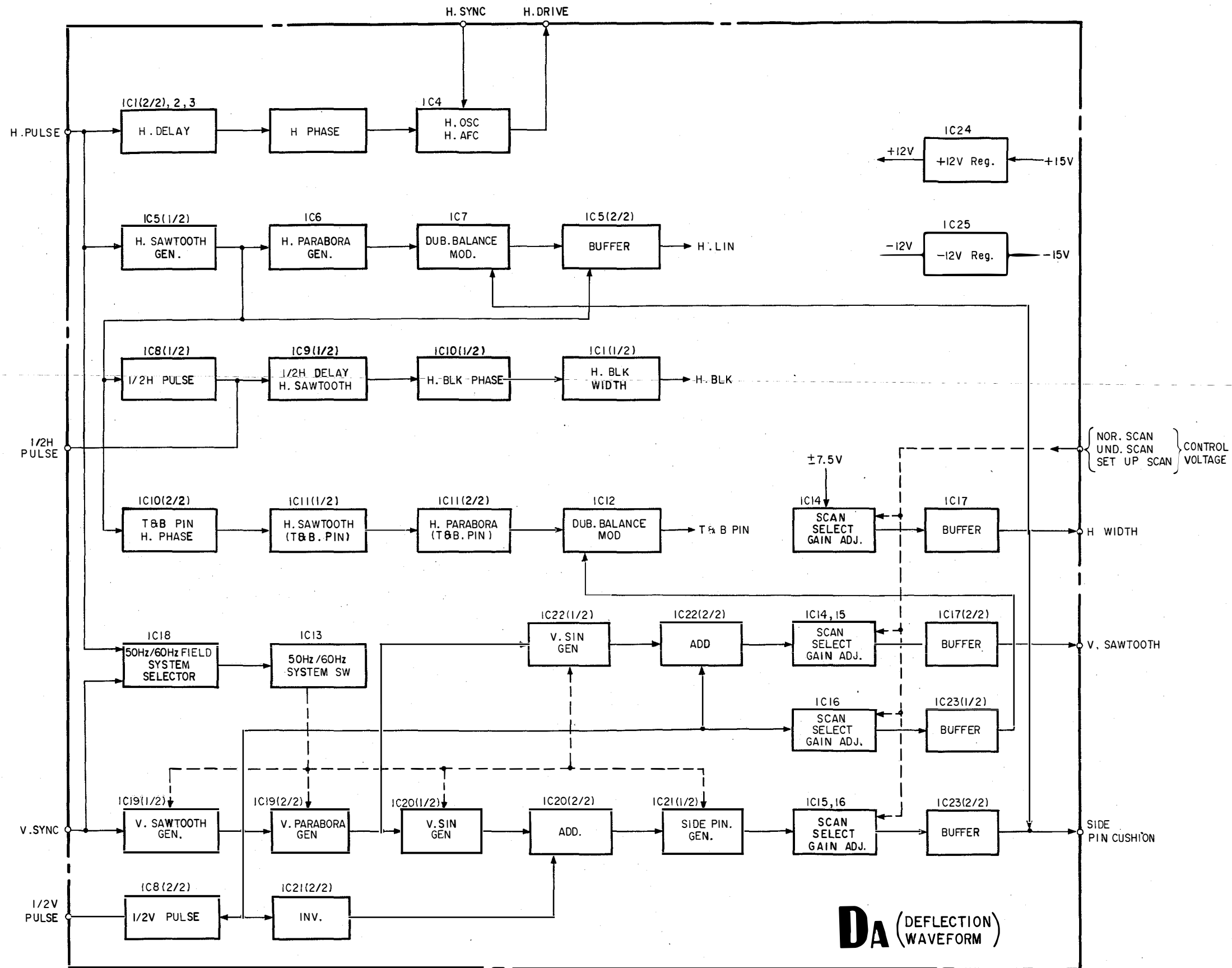

Figure 34

BLOCK DIAGRAM OF DA BOARD



DA (DEFLECTION) WAVEFORM

3-14. HORIZONTAL OUTPUT (EA BOARD)

3-14-1. Horizontal Deflection Circuit

Horizontal drive pulse for Horizontal deflection output is made at DA board and is fed to T4 (Horizontal Drive Transformer) via Q13 (H. driver). T4 is driven by Q13 and output pulse of T4 drives Q14 (Horizontal Output Transistor).

To obtain high efficiency in this model, DC-DC converter is used for side pincushion correction, Horizontal Width adjustment and +B Line voltage conversion to the horizontal deflection circuit.

This converted Line voltage is fed to horizontal deflection output circuit via H.O.T (Horizontal Output Transformer). Side pincushion correction and H. width adjustment are made by this DC-DC converter. IC-1 contains error amplifier and PWM (Pulse Width Modulator) circuit for DC-DC converter. Side pincushion correction waveform and DC voltage for H. Width adjustment are made in DA board and supplied to error amplifier to control DC-DC converter.

3-14-2. Horizontal Centering Circuit

± low voltages power supply for H centering are made in this circuit from output of secondary windings of T5 (Horizontal Output Transformer). These low voltages are converted to current source for mixing DC current on the deflection current. In this circuit Bow shaped geometry distortion due to the H centering adjustment is adjusted by providing vertical rate parabola waveform current on the H centering current.

3-14-3. Horizontal Linearity Correction Circuit

Waveform for Horizontal Linearity correction made in DA board is fed to SEPP amplifier (Single Ended Push Pull) which are composed of Q1 - Q5 transistors. Output of this amplifier is fed to H deflection circuit (Deflection Yoke) and make correction of H linearity by T1 (Horizontal Linearity Transformer).

BLOCK DIAGRAM OF EA BOARD

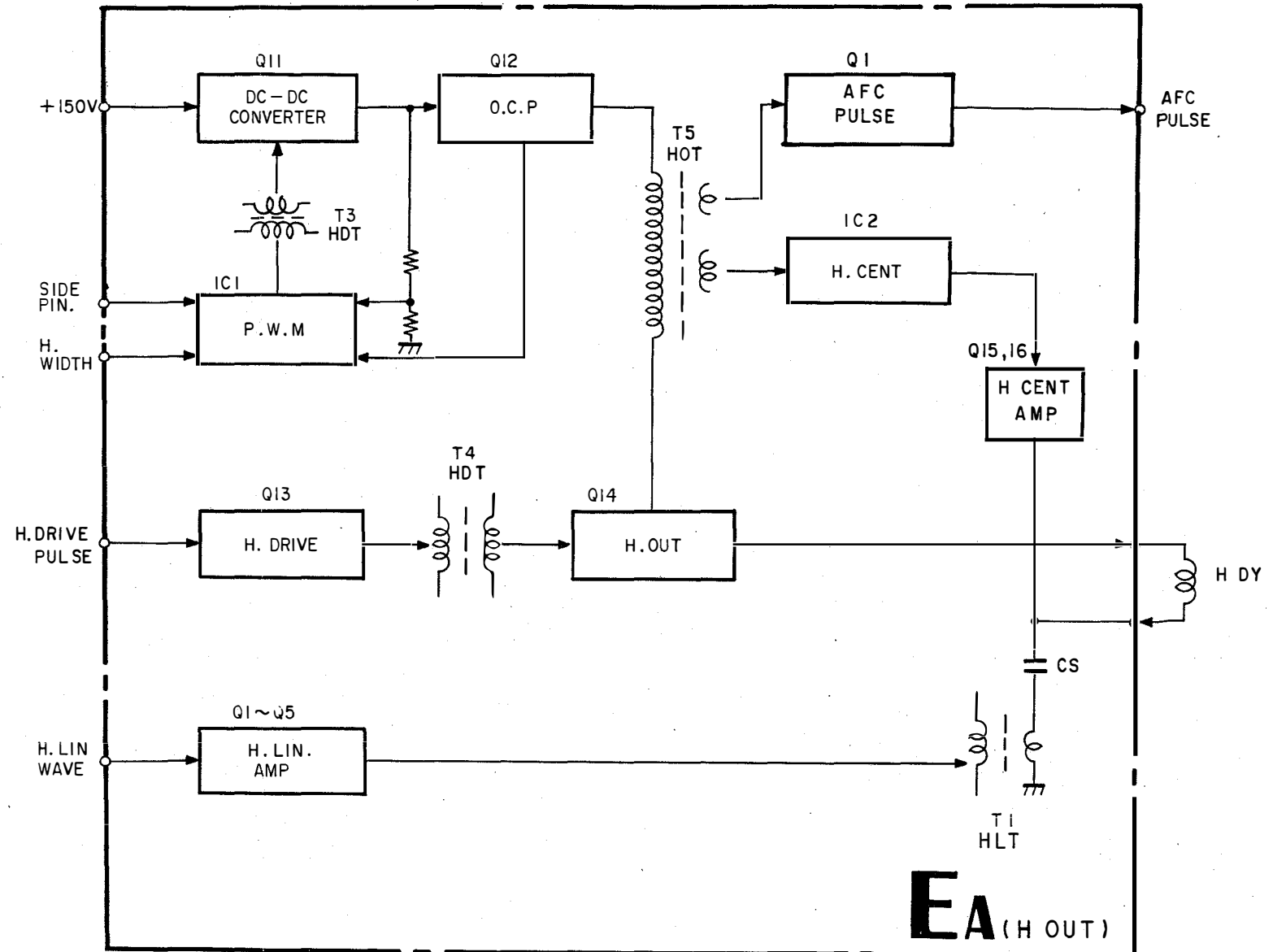

3-15. HIGH VOLTAGE REGULATOR (PA BOARD)

This high voltage regulator uses also DC-DC converter so as to reduce power consumption. The theory of operation of this circuit is as follows.

3-15-1. Detection of High Voltage

High Voltage applied to the CRT anode is converted to the low voltage by HCT block (Horizontal Convergence Transformer). This low voltage is fed to buffer amplifier IC-4(2/2) and compared with external reference voltage in IC-1. The HCT contains resistor-network and transformer for convergence adjustment. This resistor-network works as a voltage divider.

3-15-2. PWM Modulator

IC-1 works as error amplifier and PWM modulator comparing voltage between high voltage and the reference voltage is amplified and modulated so as to drive Q-102 output transistor. Output signal from IC-1, which is modulated in PWM, is fed to Q-102 via drive transformer. +B line supplied to FBT (Fly Back Transformer) circuit is controlled by switching Q-102 output transistor on/off.

3-15-3. Output Circuit

When high voltage drops down, output voltage of HCT also drops as above mentioned. At this time PWM circuit is designed so that the ON period of Q-102 output transistor should be longer than high voltage drops down. +B line, switched ON/OFF by Q-102, is supplied to converter circuit which drives FBT via LOT (Line Output Transformer).

Amount of collector current of Q-103, which drives FBT, depends upon ON period of Q-102 because PWM modulator is triggered by H. pulse. Therefore when ON period of Q-102 is longer, collector current of Q-103 increases and energy stored in capacitor C124 increases, causing potential of C124 to rise. (Refer to Figure 36) When output transistor Q-103 goes off, flyback pulse is generated by resonance between capacitor C108 and inductance obtained by parallel connection of FBT and LOT. This flyback pulse is transferred to the secondary circuit of FBT. Therefore high voltage is generated.

3-15-4. High Voltage Adjustment

High voltage is adjustable by controlling the input level of error amplifier.

3-15-5. High Voltage Protection Circuit

High voltage protector activates to shut down high voltage, when high voltage exceeds the predetermined value so as to prevent X-ray radiation.

The high voltage converted to the low voltage is detected at the terminal of HCT block. This detected voltage is fed to the ⊕ input terminal of comparator IC-2(2/2) via low pass filter, which is composed of resistor R245 and capacitor C216. When this voltage exceeds the reference voltage, the voltage of ⊖ input terminal of comparator IC-2(2/2), output level of this comparator goes high level and turns SCR (D206) gate on to shut down the drive pulse of flyback generator. Thus high voltage stops.

The reference voltage of the comparator IC-2(2/2) is made by mixing stabilized voltage (zener diode D215) and the voltage at terminal 9 of FBT. So the reference voltage goes down, when beam current of CRT increases. Therefore as beam current increases, shut-down voltage of high voltage decreases.

3-15-6. Protection Circuit for Excess Beam Current

Beam current which flows in secondary windings of FBT is measured at the terminal 9 of FBT. This beam current is converted to the voltage by resistor R1 (R3) and R2 (R4) located in PB board in series connection of secondary windings of FBT. This converted voltage is fed to ⊖ input of comparator IC-2(1/2) or IC-3(1/2). As beam current increases, ⊖ input voltage goes down. When beam current increases until ⊖ input voltage goes below the reference voltage (⊕ input terminal voltage) output voltage of comparator goes up high level and SCR (D205 or D206) turns ON. Thus drive pulse of flyback generator is shut down. Therefore high voltage stops.

3-15-7. CRT Protection Circuit

When vertical deflection stops, this circuit activates to shut down high voltage to prevent damage of CRT.

When vertical deflection stops, there is no vertical output pulse generated at vertical output amplifier. So Q201 transistor is cut off and output of comparator IC-4(1/2) goes up high level. Q202 transistor turns on and flyback generator stops.

3-15-8. G2 Voltage Regulator

Flyback pulse generated at Q103 (H output transistor) is rectified to obtain DC voltage. This rectified DC voltage is regulated by Q104, IC-3(1/2) and Q106 transistor. Regulated 410V DC voltage is obtained. Q105 transistor which works in accordance with G2 control circuit in BI board supplied proper voltage to G2 of CRT.

3-15-9. Power Supply for Heater

Power supply to heater is generated from secondary windings of LOT. Heater voltage is adjusted by resistor R107.

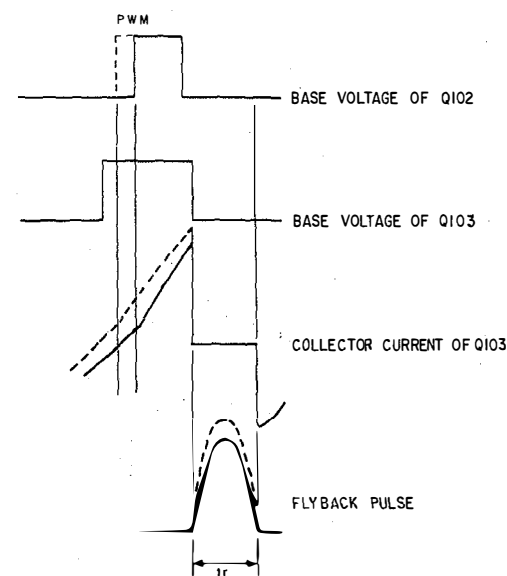

Figure 35

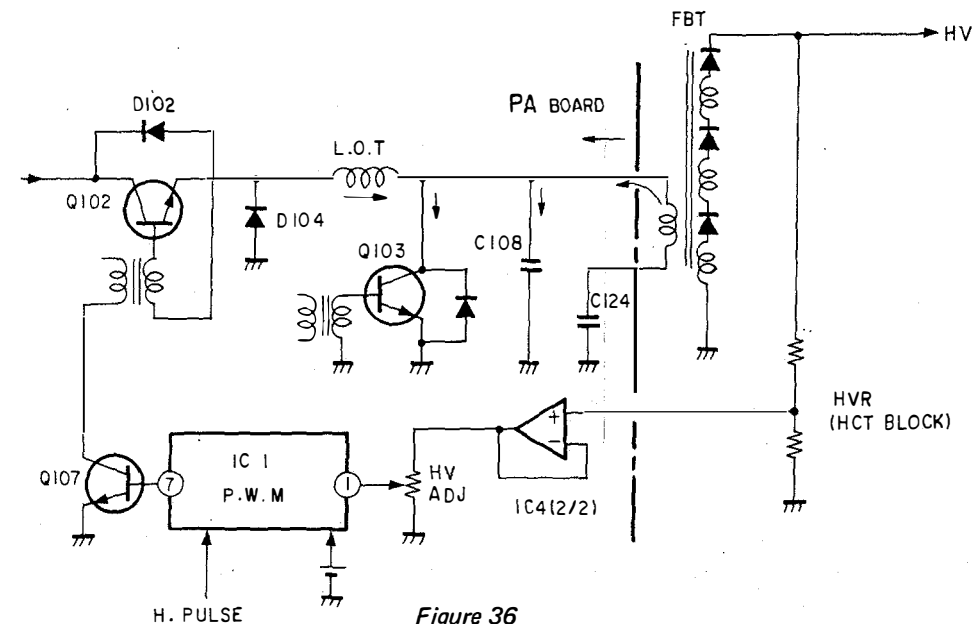
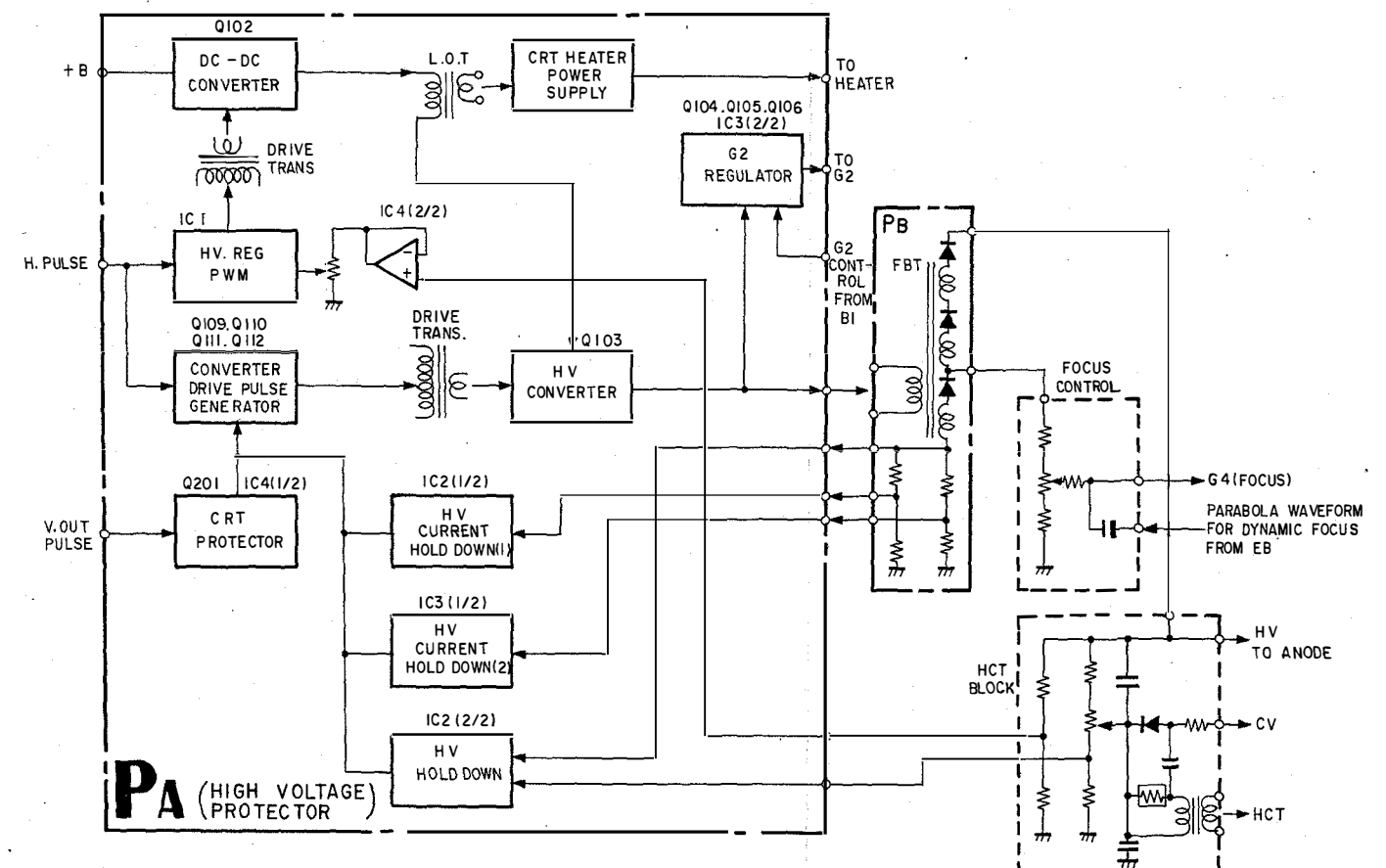

Figure 36

BLOCK DIAGRAM OF PA BOARD



SECTION 4 ADJUSTMENTS

4-1. INTERNAL VIEW

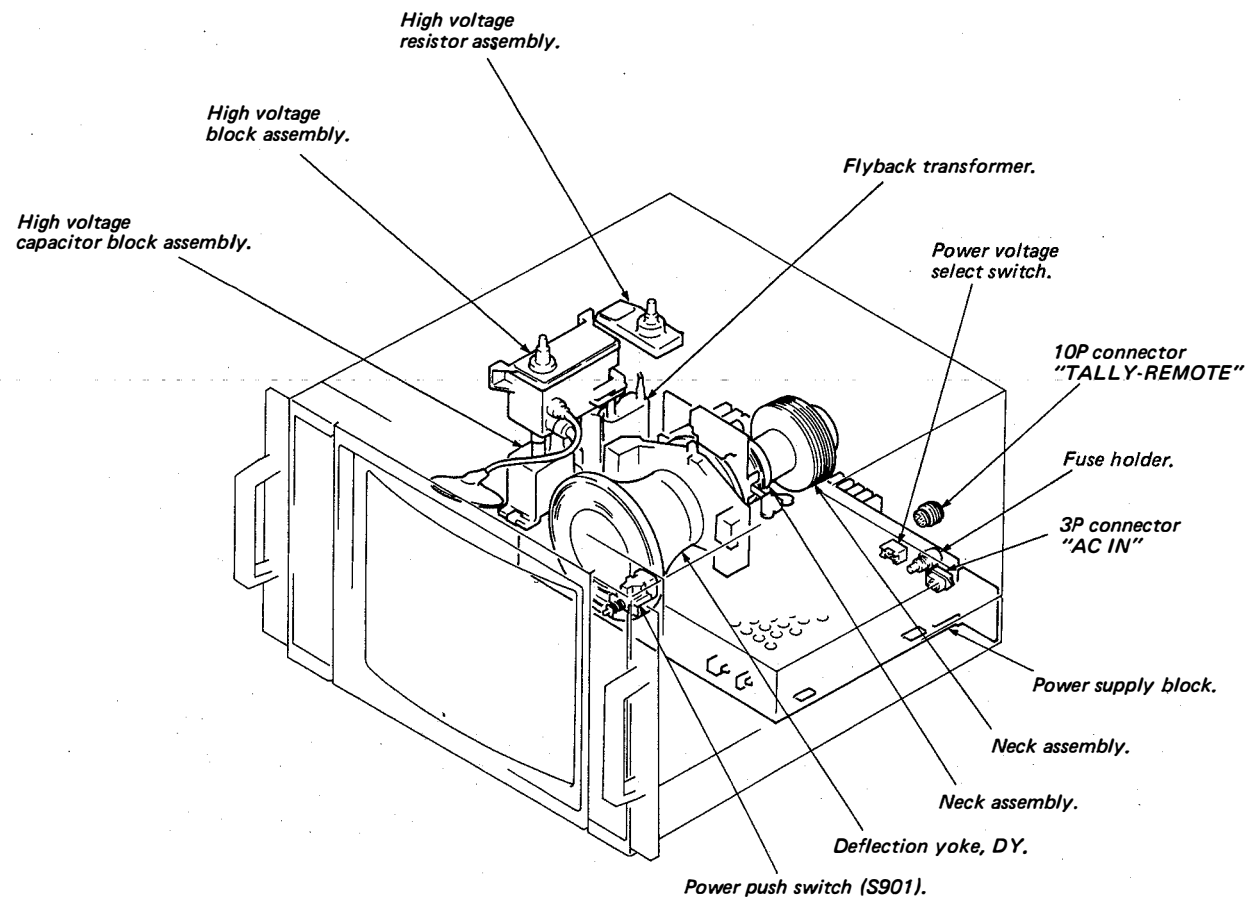

4-2. CIRCUIT BOARDS LOCATION

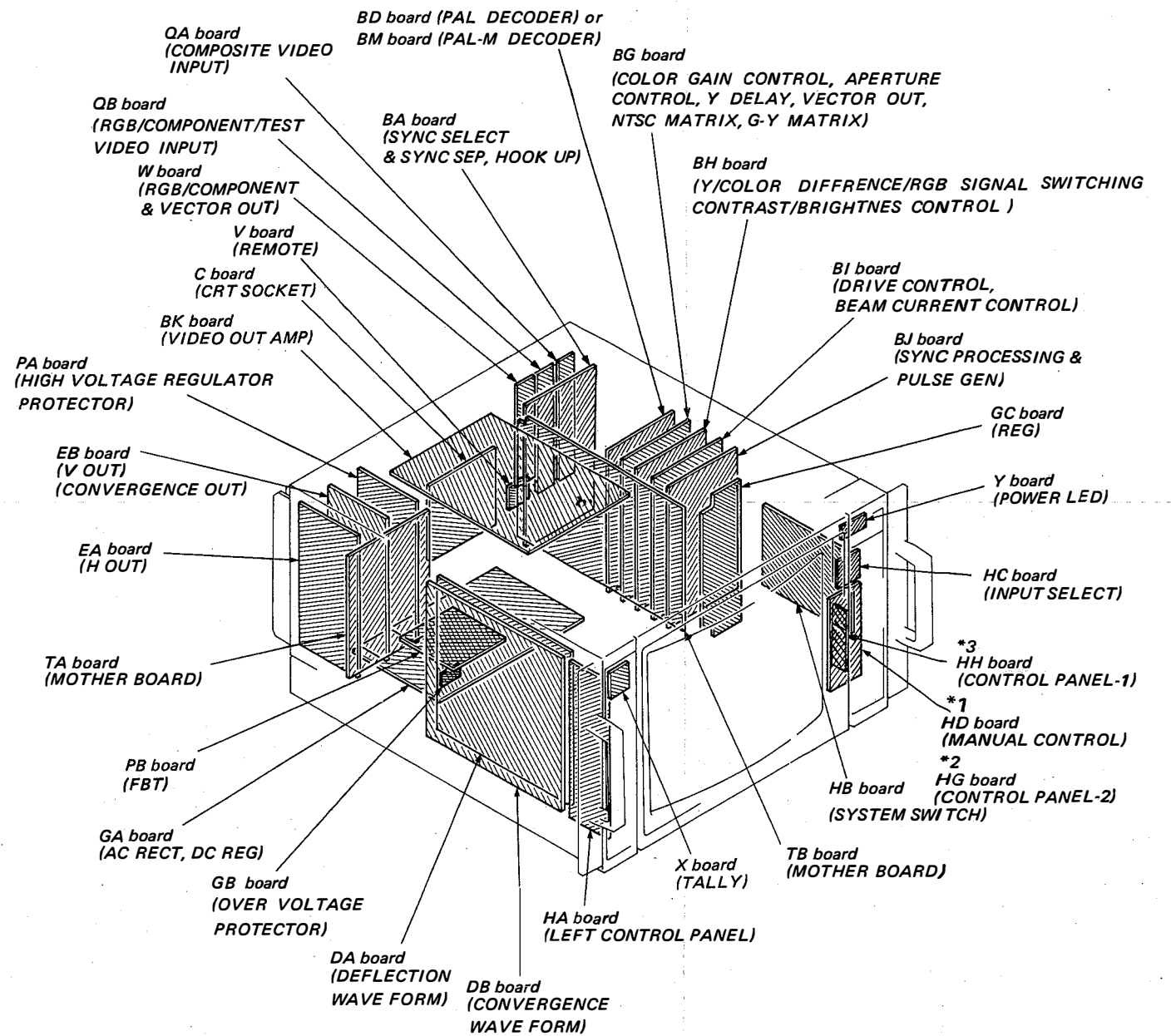

- *1
HD board
BVM-1410P ONLY Serial No. up to 2,001,396
BVM-1410PM ONLY Serial No. up to 2,000,020
- *2, 3
HG, HH board
BVM-1410P ONLY Serial No. 2,001,397 and Higher
BVM-1410PM ONLY Serial No. 2,000,021 and Higher

4-3. QUICK REFERENCE

SECTION \ BOARD	BA	BD	BM	BG	BH	BI	BJ	BK	DA	DB	EA	
CIRCUIT DESCRIPTION	3-1	3-17	3-19	3-3	3-5	3-7 3-15	3-9	3-13 3-15	3-29	3-25 3-27	3-33	
ADJUSTMENTS	4-21 4-23	4-31		4-21 4-27 4-49	4-21	-	4-19 4-30 4-46	4-47	4-50	-	-	
BLOCK DIAGRAM	3-2	3-18	3-20	3-4	3-6	3-8	3-10	3-14	3-31	3-26	3-34	
MOUNTING DIAGRAM	5-7	5-15		5-17	5-25	5-27	5-35	5-37	5-45	5-47	5-52	
SCHEMATIC DIAGRAM	5-9	5-13		5-19	5-23	5-29	5-33	5-39	5-43	5-49	5-55	
ELECTRICAL PARTS LIST	7-1	7-3		7-7	7-9	7-11	7-14	7-16	7-19	7-22	7-25	
SECTION \ BOARD	EB	GA	GB	C	PA	PB	HA	HB	HC	HD	X	
CIRCUIT DESCRIPTION	3-21 3-25	3-23	3-23	-	3-35	-	-	-	-	-	-	
ADJUSTMENTS	-	-	-	-	-	-	-	4-18 4-21	-	-	-	
BLOCK DIAGRAM	3-22 3-26	3-24	3-24	-	3-36	-	-	-	-	-	-	
MOUNTING DIAGRAM	5-53	5-59	5-58	5-64	5-65	5-64	5-70	5-70	5-69	5-69	5-69	
SCHEMATIC DIAGRAM	5-55	5-61	5-62	5-68	5-67	5-68	5-72	5-71	5-71	5-72	5-72	
ELECTRICAL PARTS LIST	7-26	7-27	7-27	7-18	7-32	7-33	7-30	7-31	7-31	7-31	7-35	
SECTION \ BOARD	Y	GC	QA	V	W	TA	TB	Z	HE	QB	HG	HH
CIRCUIT DESCRIPTION	-	-	3-1	-	-	-	-	-	-	3-1	-	-
ADJUSTMENTS	-	-	-	-	-	-	-	-	-	-	-	-
BLOCK DIAGRAM	-	-	3-2	-	-	-	-	-	-	3-2	-	-
MOUNTING DIAGRAM	5-69	5-73	5-73	5-74	5-73	5-77	5-81	5-85	-	5-73	5-69	5-69
SCHEMATIC DIAGRAM	5-72	5-75	5-75	5-76	5-75	5-79	5-83	-	-	5-76	5-71	5-71
ELECTRICAL PARTS LIST	7-35	7-30	7-34	7-35	7-35	7-34	7-34	-	7-31	7-34	7-31	7-32

4-4. SUB CONTROL PANEL LOCATION

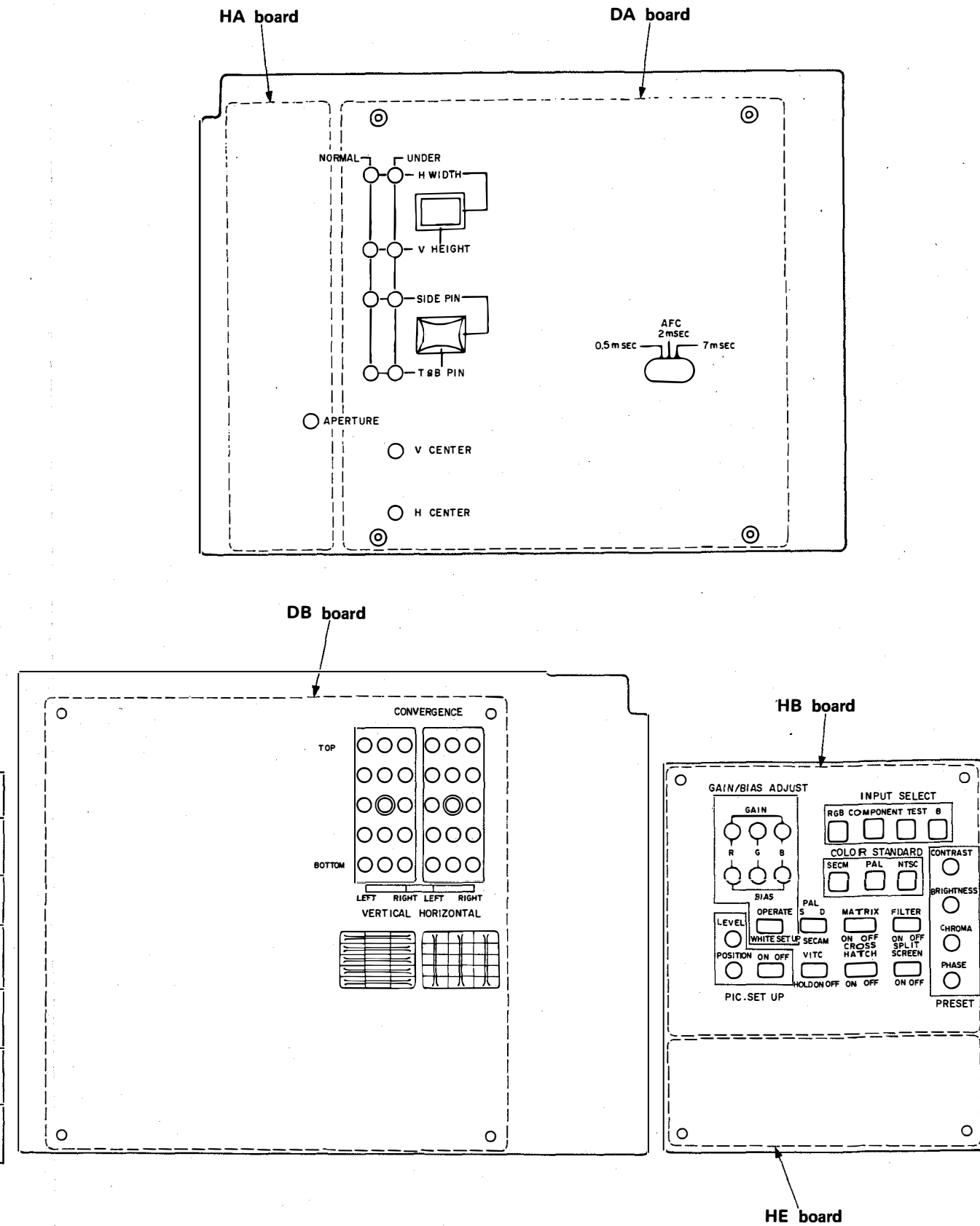

4-5. SETUP ADJUSTMENT IN CASE OF PICTURE TUBE REPLACEMENT

When the picture tube has been replaced, make the following adjustments. Convergence and white balance are normally adjusted by POT's on the sub control panel.
(Refer to pages 4-6, 4-7 and 4-9)

[Jigs Tools and Measurement Equipment Required]

1. SIGNAL GENERATOR (TEKTRONIX 1411, 1412 Series)
2. COLOR ANALYZER
3. LUMINANCE METER

[Landing adjustment]

1. Connect signal generator and receive a white signal.
2. Turn BRIGHTNESS and CONTRAST switch PRESET (□).
3. Face the CRT screen toward East (or West) and press the DEGAUSS switch.
4. Set the purity knob to mechanical center as shown in Fig.1-1.
(You can see through the hole.)

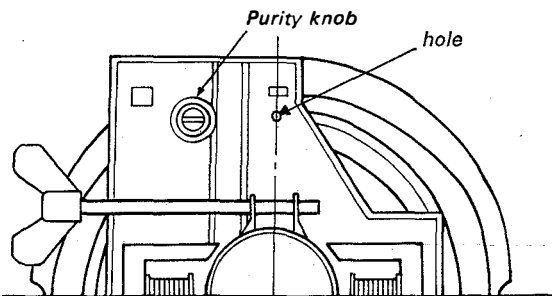

Fig. 1-1.

5. Slide DY (Deflection Yoke) as far forward as possible.
6. Set the neck assembly in the position shown in Fig. 1-2.

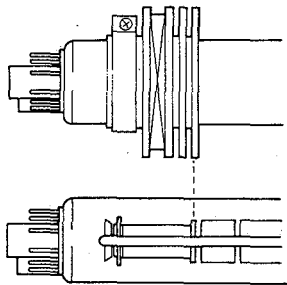

Fig. 1-2.

7. Set the screen to green only (R and B on the FRONT PANEL (L) are in the IN position and G in the OUT position).
8. Turn purity knob as shown in Fig. 1-3 to bring the green on the center of the screen.

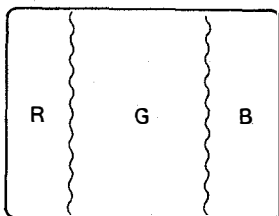

Fig. 1-3.

9. Slide DY back for uniform green raster.
10. Make the screen red only (G and B on the FRONT PANEL (L) are in the IN position and R in the OUT position) and check landing.
11. Make the screen blue only (R and G on the FRONT PANEL (L) are in the IN position and B in the OUT position) and check landing.
12. Adjust DY tilt and tighten DY set-screw.
(Using an internal cross hatch signal (S13 on HB Boards), it is easy to adjust DY tilt.)
13. Secure the DY with the spacers. (Fig. 1-4)

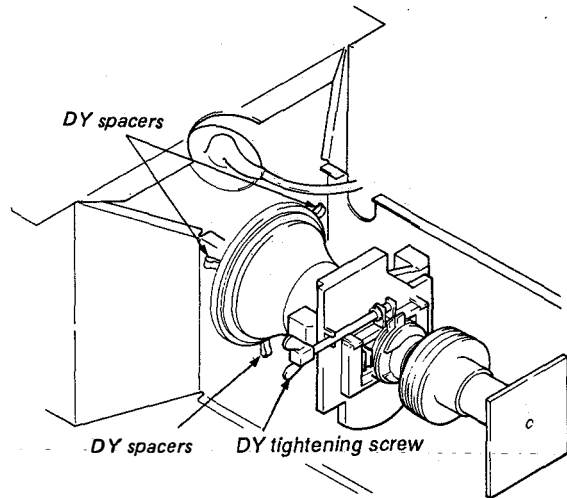
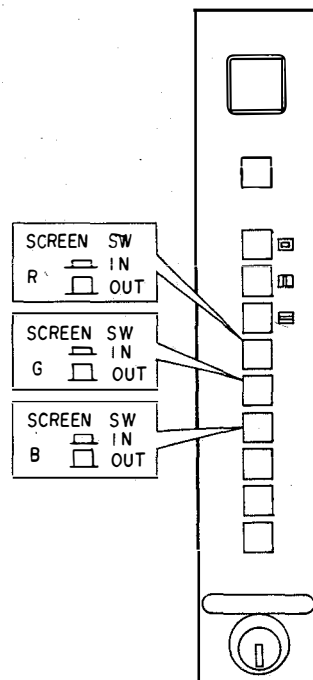

Fig. 1-4.

• Final check

After adjustments, check that there is no mislanding by facing the CRT towards East, West, North and South directions.

FRONT PANEL (L)



[Focus adjustment]

1. Connect signal generator (1411 and 1412 series).
2. Input a dot or cross-hatch signals.
3. Adjust the FOCUS control for best focus in the central portion of the screen as shown in Fig. 1-5.

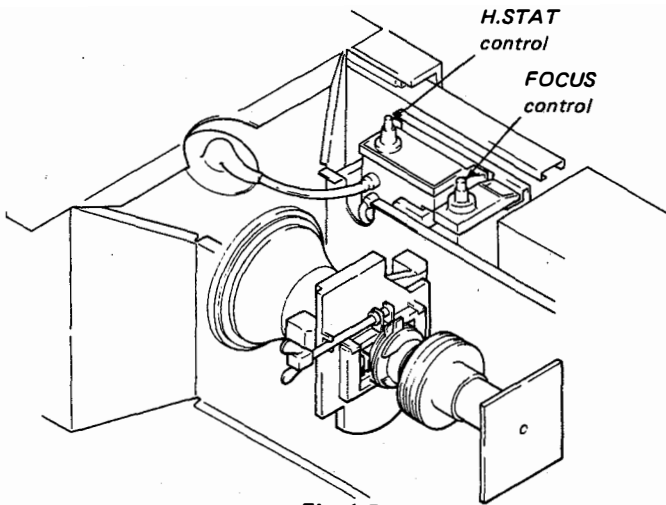

Fig. 1-5.

[Convergence Adjustment]

Preparation

1. Complete the signal generator connection and feed the dot and cross-hatch signals.
2. Set the CONTRAST and BRIGHTNESS controls at the points where the dots and the cross-hatch can be observed clearly.
3. Set the H. STATIC CENTER control (RV23) and V. STATIC CENTER control (RV8) on the DC board to mechanical center as shown in Fig. 1-6.

DB board

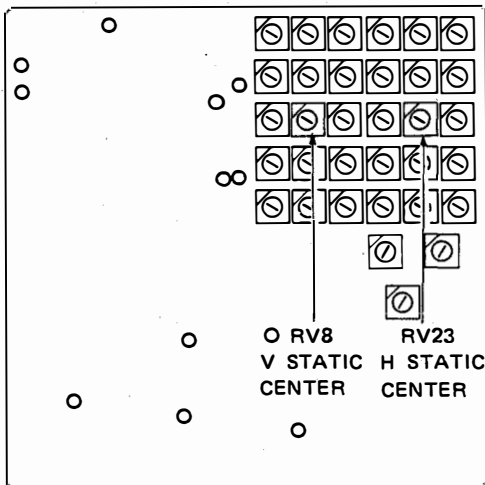

* Mechanical center

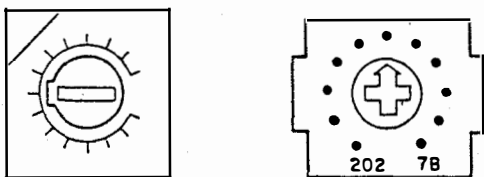

Fig. 1-6.

[Static Convergence]

• Horizontal Static Convergence

1. Adjust H. STAT control of HV BLOCK to match the convergence of red and green in the horizontal direction at screen center.
2. Perform the HMC correction when blue is out of convergence in the same direction on all over the screen.
3. Move the BMC magnet to correct H. static convergence as shown in Fig. 1-8.

• Vertical Static Convergence

1. Adjust the V. STATIC CENTER (RV8) on the DB board to match the convergence of red and green in the vertical direction at screen center.
2. When blue is out of the convergence in the same direction all over the screen, perform the VMC correction.
3. Move the BMC magnet to correct static convergence as shown in Fig. 1-9.

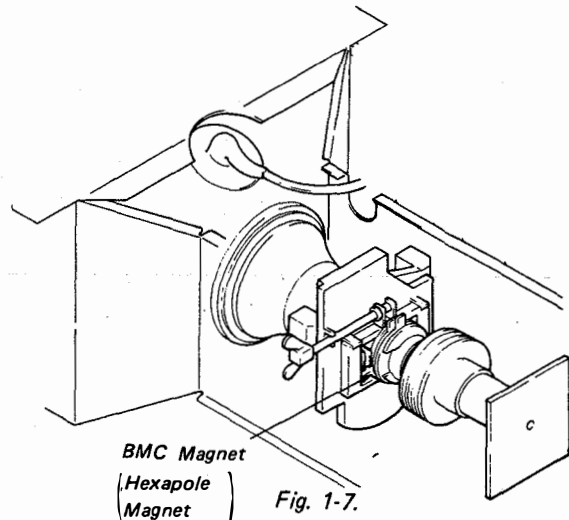
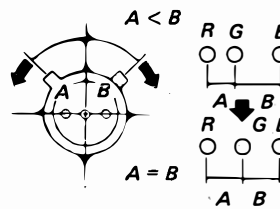

Fig. 1-7.

• HMC and VMC correction for BMC Magnet.

1. HMC (Horizontal, Mis, convergence) correction and motion of the Electron Beam with the Hexapole Magnet.

HMC correction (A)



HMC correction (B)

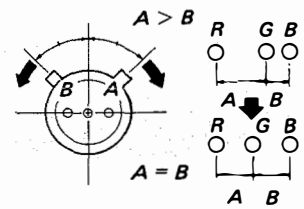
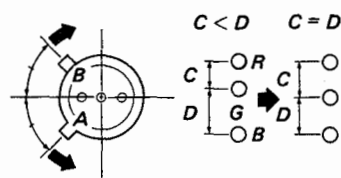

Fig. 1-8.

2. VMC (Vertical, Mis, convergence) correction and motion of the Electron Beam with the Hexapole Magnet.

VMC correction (A)



VMC correction (B)

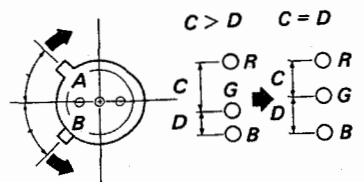

Fig. 1-9.

[DYNAMIC CONVERGENCE]

1. Adjust CONVERGENCE controls (RV1 ~ RV30) on the DB board as shown in Fig. 1-10.
2. It can be adjusted as Red and Blue move in symmetry to the Green. (Green does not move)
3. Adjust the convergence corresponding to the portion of the screen as follows.
4. Always match the convergence in the order of center → on Y axis → on X axis → corner against the screen.
(Recomandatory order is shown in Sub control panel inside the drawer).

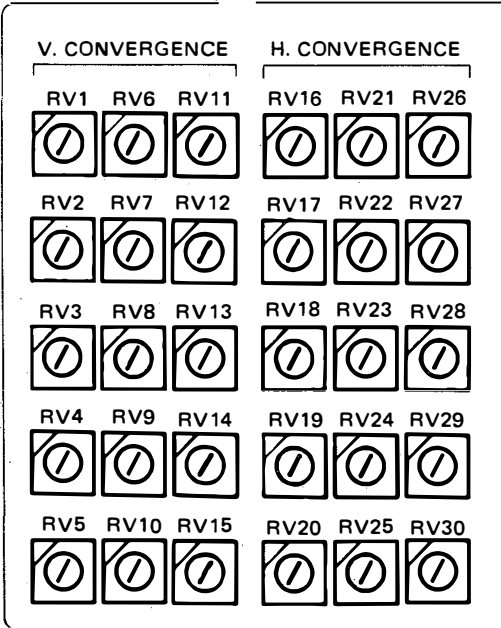
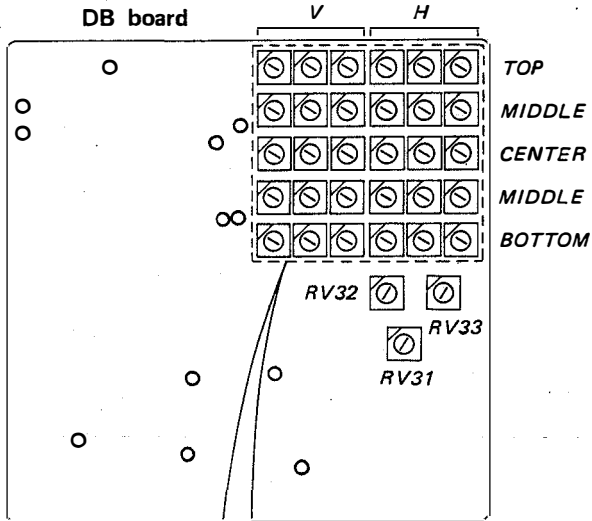

Fig. 1-10.

[CONVERGENCE PROCESS]

1. UNDER SCAN switch NOR (□)
2. Adjust RV23 and RV8 on the DB board to coincide with R, G and B dots at the center of the screen as shown in Fig. 1-11.

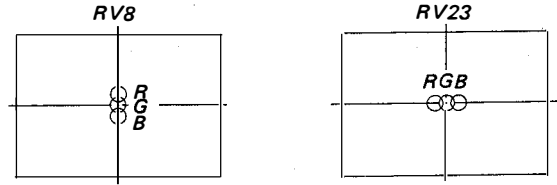

Fig. 1-11.

3. Adjust RV6, RV10, RV21, and RV25 on the DB board to coincide with the R, G and B dots as shown in Fig. 1-12.

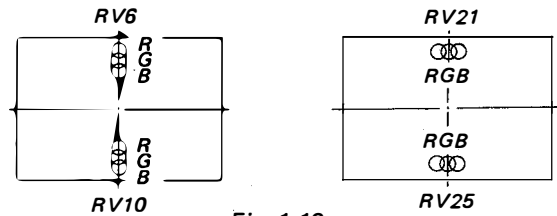

Fig. 1-12.

4. Adjust RV3, RV13 and RV18, RV28 on the DB board to coincide with the R, G and B dots as shown in Fig. 1-13.

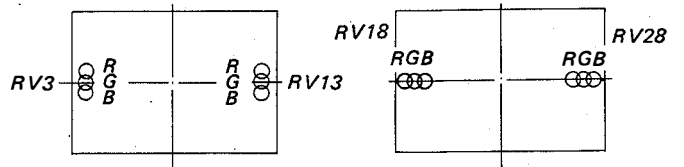

Fig. 1-13.

5. Adjust RV1, RV5 and RV11, RV15 on the DB board to coincide with the R, G and B dots as shown in Fig. 1-14.

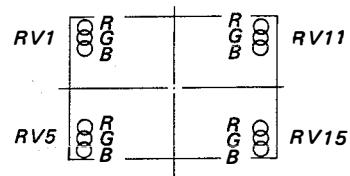

Fig. 1-14.

6. Adjust RV16, RV20 and RV26, RV30 on the DB board to coincide with the R, G and B dots as shown in Fig. 1-15.

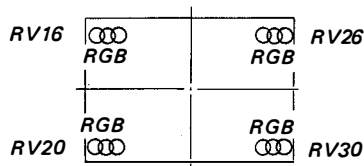

Fig. 1-15.

7. Adjust RV7, RV9 and RV22, RV24 on the DB board to coincide with the R, G and B dots as shown in Fig. 1-16.

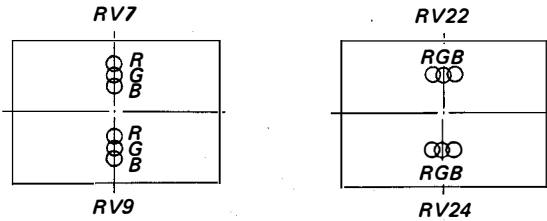

Fig. 1-16.

8. Adjust RV2, RV4 and RV12, RV14 on the DB board to coincide with the R, G and B dots as shown in Fig. 1-17.

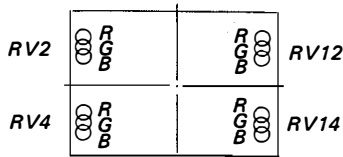

Fig. 1-17.

9. Adjust RV17, RV19 and RV27, RV29 on the DB board to coincide with the R, G and B dots as shown in Fig. 1-18.

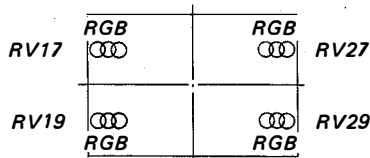

Fig. 1-18.

10. UNEDR SCAN switch UNDER (⏏)
 11. Adjust RV31 (UNDER SCAN Y. BOW) on the DB board to coincide with the R, G and B dots as shown in Fig. 1-19.

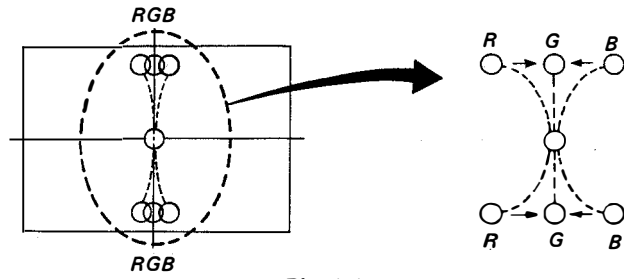

Fig. 1-19.

12. Adjust RV32 and RV33 (UNDER SCAN H. AMP) on the DB board to coincide with the R, G and B dots as shown in Fig. 1-20.

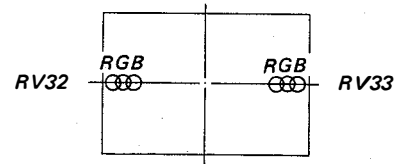
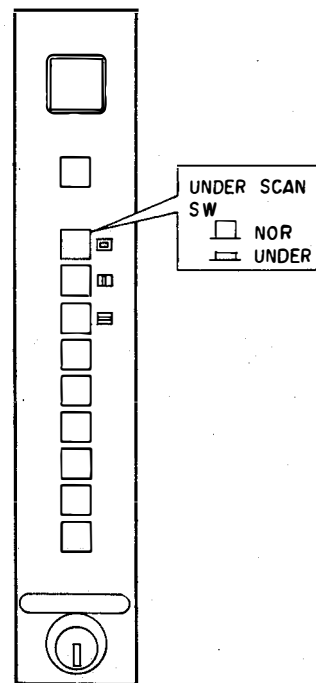
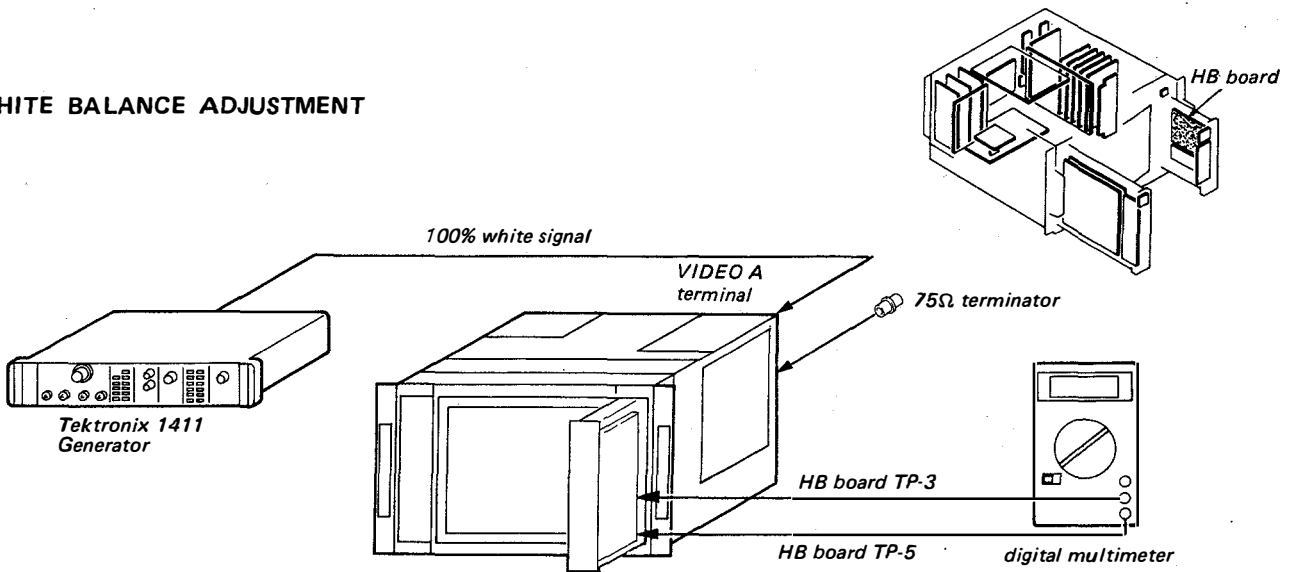

Fig. 1-20.

FRONT PANEL (L)



WHITE BALANCE ADJUSTMENT



1. Input 100% white signal to VIDEO A connector.
2. WHITE/OPERATE/SET UP switch SET UP.
3. Connect the digital multimeter between the mechanical center of the RV2 and GND on the HD board.
4. BRIGHTNESS MANUAL switch MANUAL. (☐)
5. Adjust with the BRIGHTNESS control so that the voltage of the digital multimeter becomes -0.7 vdc.
6. Turn BIAS controls (RV8: Red, RV9: Green, RV10: Blue) on the HB board to adjust the BRIGHTNESS to 0.5NIT and white balance using COLOR ANALYZER and check 0.5NIT by LUMINANCE METER.
7. BRIGHTNESS MANUAL switch PRESET (☐)
8. WHITE/OPERATE/SET UP switch OPERATE.
9. Turn GAIN controls (RV5: Red, RV6: Green, RV7: Blue) on the HB board to adjust the BRIGHTNESS at HIGH LIGHT to 103 NIT and white balance using COLOR ANALYZER and check 103 NIT by LUMINANCE METER.
10. Repeat procedure steps 4 to 9 if necessary.

*1 HD board is replaced by HG board from the serial No. shown below.
 In this case, connect the digital multimeter between the TP1 and GND on the HG board.

HG board:
 BVM-2010P only, serial No. 2001397 and higher
 BVM-2010PM only, serial No. 21000021 and higher

FRONT PANEL (R)

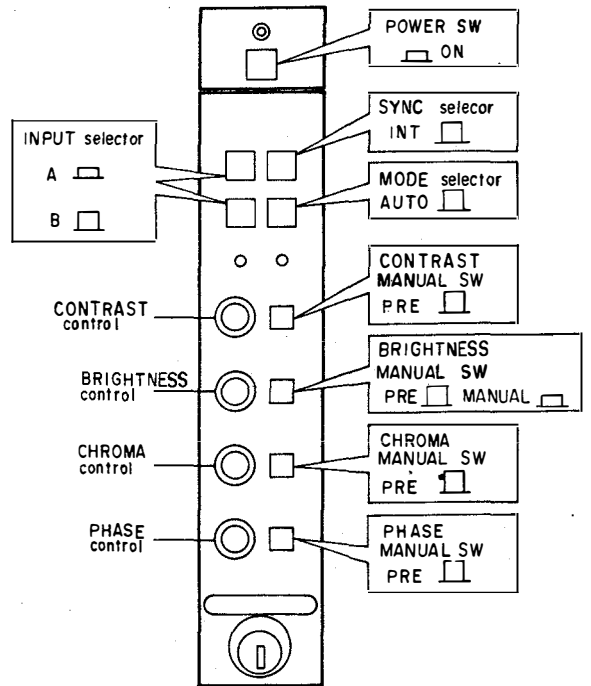

HB board

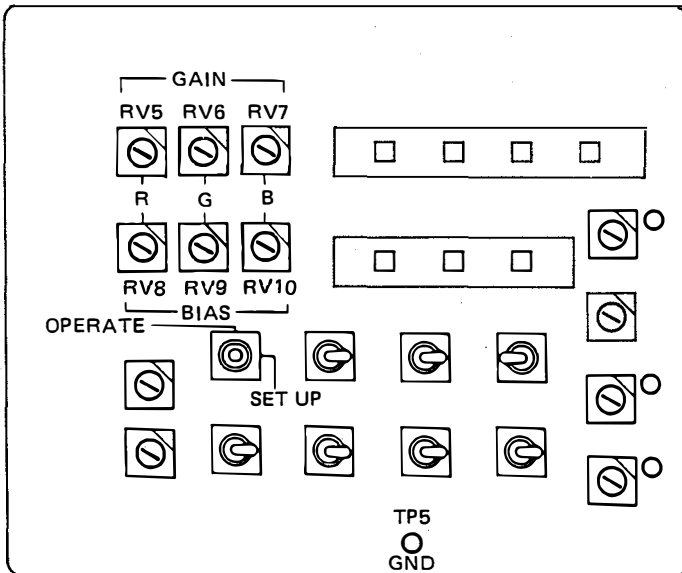

4-6. SAFETY RELATED ADJUSTMENTS

+B PROTECTOR (R52, R53)

When replacing the following components (marked on the schematic diagram), make this confirmation.

- GA Board . . R52, R53, Q14, Q13
- GB Board . . D5, D6, R5, Q4, Q3, D7, R4, Q5, D8, R19, R20, R21, R22

It is necessary to use a digital multimeter for this confirmation.

Connect a digital multimeter to TP2 on GA Board.

1. Receive a color bar signal and set CONTRAST and BRIGHTNESS controls to preset position. (manual bottom is out.)
2. Short-circuit R55 on GA Board.
3. Connect 100k Ω variable resistor with R68 in parallel on GA Board.
4. Confirm that the reading on the digital multimeter drops abruptly from +182.0V ~ +216.0V to 0V by turning the 100k Ω variable resistor so that the value of the resistor decrease from maximum value.
5. If step 4 isn't satisfied, check that the mounted components are correct.

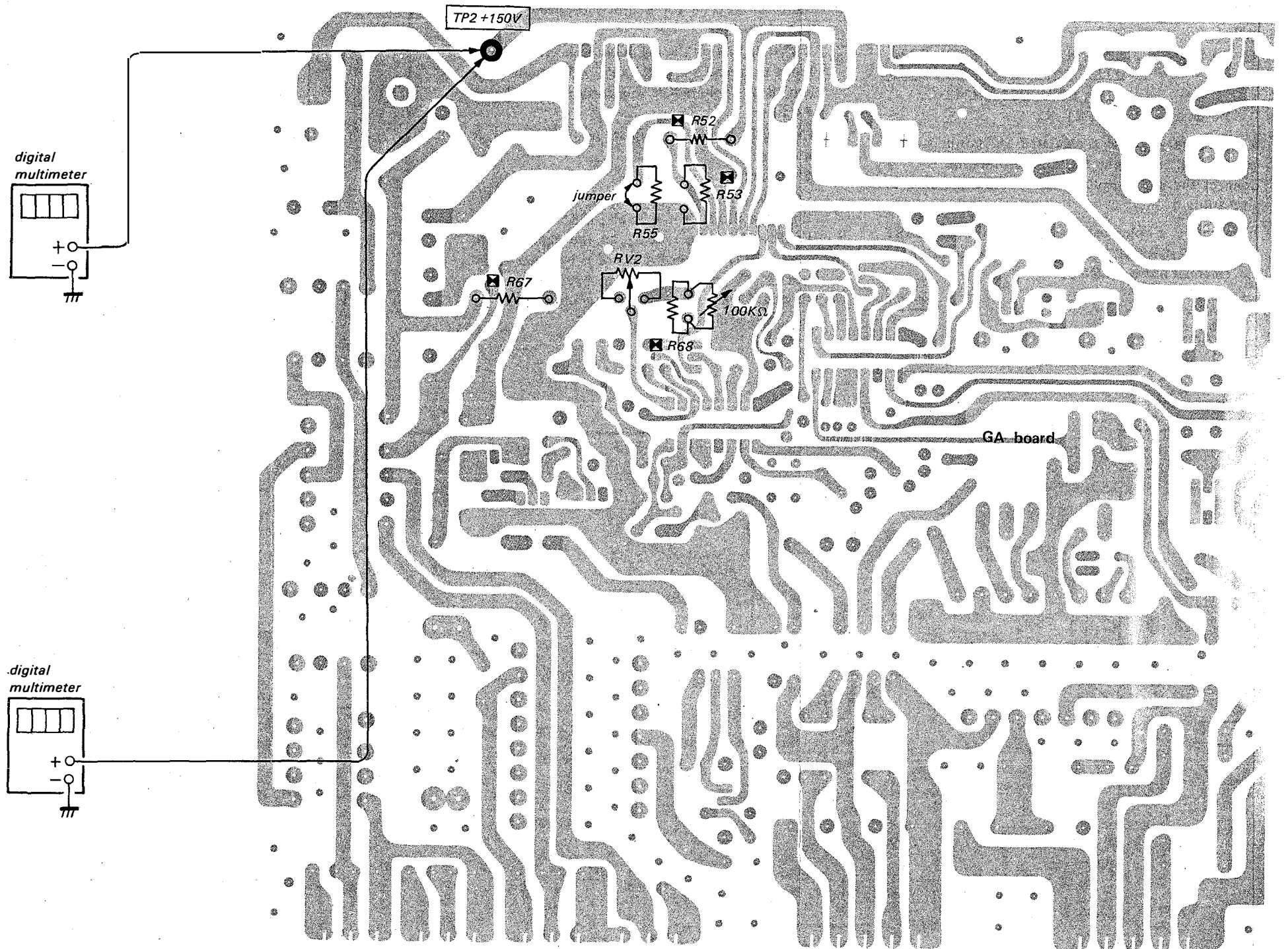

+B MAX CONFIRMATION (R67, R68)

When replacing the following components (marked on the schematic diagram), make this confirmation.

- GA Board . . R67, RV2, R68, IC3, C59, R78

It is necessary to use a digital multimeter for this confirmation.

Connect a digital multimeter to TP2 on GA Board.

1. Receive a color bar signal and set CONTRAST and BRIGHTNESS controls to preset position. (manual bottom is out.)
2. Confirm that the reading on the digital multimeter is between +155.0V and +175.0V when RV2 variable resistor is turned to fully clockwise.
3. After confirmation, make the reading on the digital multimeter into +150.0V \pm 0.5V by adjusting RV2 on GA Board.

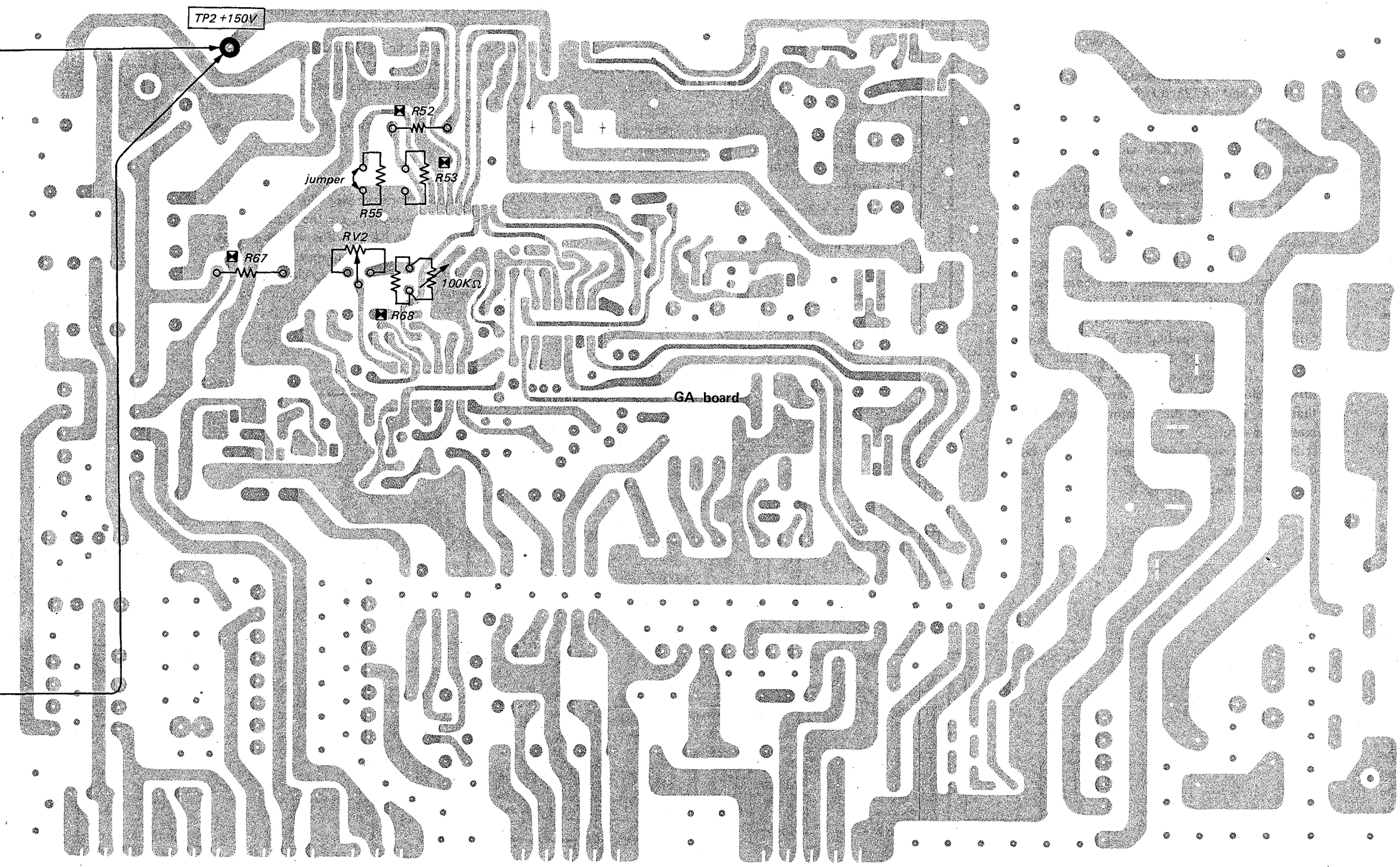

HIGH VOLTAGE HOLD DOWN ADJUSTMENT AND CONFIRMATION

When replacing the following components (marked on the schematic diagram), make this adjustment.

- DCT Block
- PA Board . . . IC2, R201, R202, D215, R225, R226, R227, R228, D214, R229, R230, D207, R213, R214, D205, R243

It is necessary to use an electrostatic voltmeter or equivalent for this adjustment. Connect the electrostatic voltmeter to the anode cap.

Even though an electrostatic voltmeter may not be used, connect digital multimeters to TP1 and ⑦ pin of IC4 and IHV(1) on PA Board.

Note: Use an electrostatic voltmeter which is calibrated, and which has $2 \times 10^9 \Omega$ or more input impedance.

example: ESH-27X or ESH-23X of the SINGER COMPANY

Use a digital multimeter which has 4 digit or more.

IN case of using electrostatic voltmeter

1. Receive a color bar signal and set CONTRAST and BRIGHTNESS controls to fully counter-clockwise. (manual button is IN)
2. Connect 200k Ω variable resistor with R125 in parallel on PA Board.
3. Confirm and memorize that the reading on the electrostatic voltmeter drops abruptly from 29.0kV ~ 27.0kV to 0V by turning slowly the 200k Ω variable resistor so that the value of the resistor decrease from maximum value.
4. If step 3 can not be performed, select the value of R227 and R228 (1/6W metal-film) and repeat above step 3.
5. Set CONTRAST and BRIGHTNESS controls to fully clockwise. (maximum; the reading on the digital multimeter of IHV(1) on PA Board should be between -5.9V and -7.7V)
6. Confirm and memorize that the reading on the electrostatic voltmeter drops abruptly from 28.0kV ~ 26.0kV to 0V by turning slowly the 200k Ω variable resistor and check the difference of memorize voltage between in step 3 and 6 is over 400V.

In case of using a digital multimeter

1. Receive a color bar signal and set CONTRAST and BRIGHTNESS controls to fully counter-clockwise. (manual button is IN)

(R227, R228)

2. Connect 200k Ω variable resistor with R125 in parallel on PA Board.
3. Confirm that the reading on the digital multimeter of TP1 on PA Board is between 9.10V and 9.30V.
4. If step 3 can not be performed, select the value of R227 and R228 (1/6W metal-film) and repeat above step 3.
5. Confirm that the reading on the digital multimeter at ⑦ pin of IC4 on PA Board drop abruptly from between 9.10V and 9.35V by turning slowly the 200k Ω variable resistor.
6. If step 5 can not be performed, select the value of R227 and R228 (1/6W metal-film) and repeat above step 3 through 5.
7. Set CONTRAST and BRIGHTNESS controls fully clockwise. (maximum; the reading on the digital multimeter of IHV(1) on PA Board should be between -5.9V and -7.7V)
8. Confirm that the reading on the digital multimeter at ⑦ pin of IC4 on PA Board drops abruptly from between 9.05V and 8.85V by turning slowly the 200k Ω variable resistor so that the value of the resistor decrease from maximum value.
9. If step 8 can not be performed, select the value of R227 and R228 (1/6W metal-film) and repeat above step 3 through 8.

BEAM CURRENT PROTECTOR 1 CONFIRMATION

(R222)

When replacing the following components (marked on the schematic diagram), make this confirmation.

- PA Board . . . R201, R202, D215, R220, R221, R222, R223, R224, IC2, D206, R213, R214, D205, R242
- PB Board . . . FBT, R1, R2

It is necessary to use a regulated DC power supply and a digital multimeter for this confirmation. Connect the digital multimeters to TP2 and IHV(1) on PA Board.

1. Receive a color bar signal and set CONTRAST and BRIGHTNESS controls to preset position. (manual button is OUT)

2. Confirm that the reading on the digital multimeter of TP2 on PA Board is between +31.0V and +33.5V.
3. If the reading on the digital multimeter of TP2 is more than +32.5V, 1M Ω $\pm 1\%$ 1/6W (metal-film) should be mounted at the portion of R222 on PA Board. (Normally in this position no component is mounted.)
4. Short-circuit R213.
5. Connect a regulated dc power supply to IHV(1) through a diode. (for example, 1SS119).
6. Confirm that the reading on the digital multimeter of IHV(1) on PA Board is between -7.6V and -11.8V when the raster disappears.
7. If step 6 can not be perform, check that the mounted components are correct.

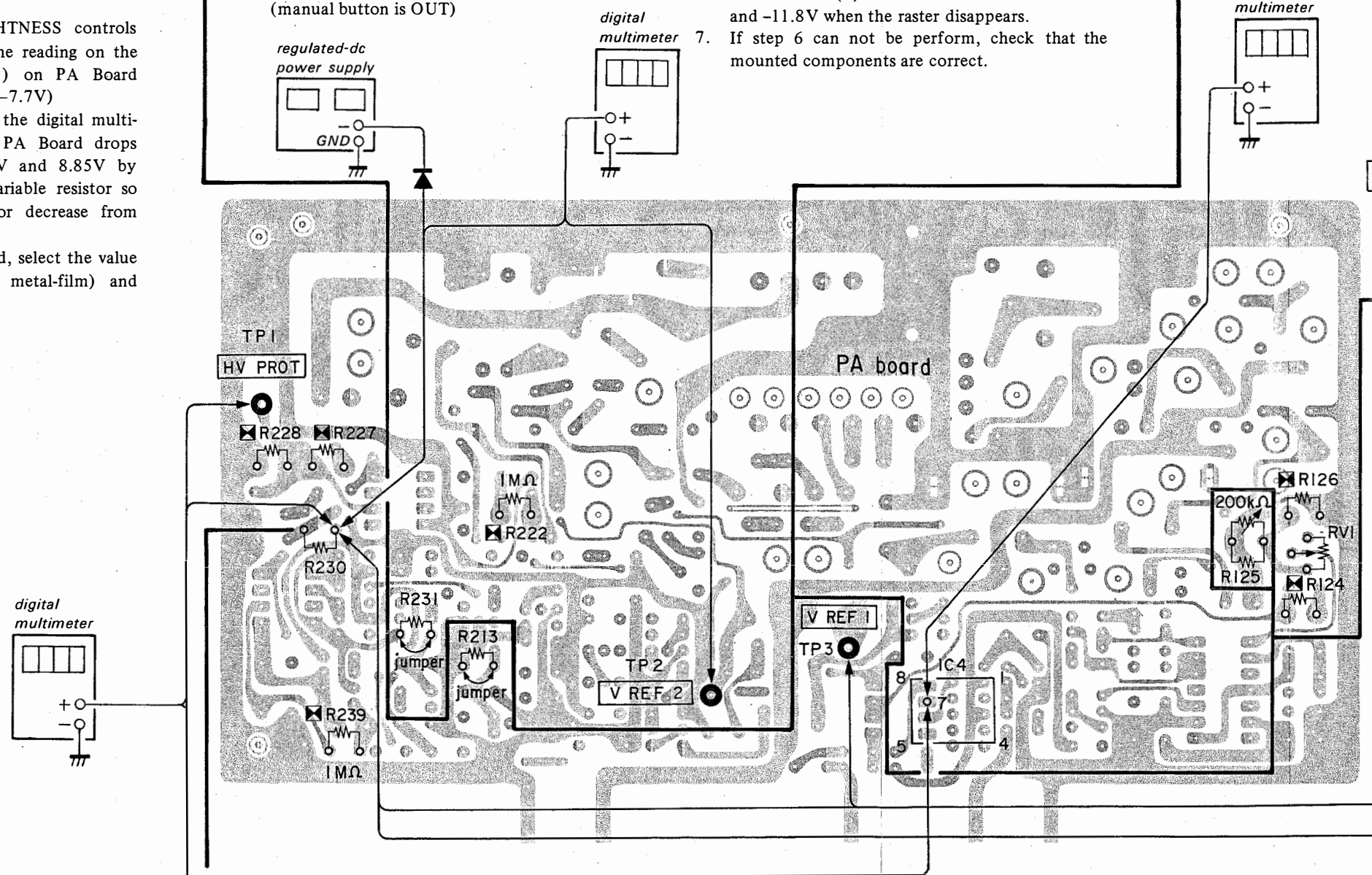

HIGH TIO

When on I F

It is equiv static Even used, on P/ **Note**

In 1.

BEAM CURRENT PROTECTOR 1 CONFIRMATION

(R222)

When replacing the following components (marked on the schematic diagram), make this confirmation.

- PA Board . . R201, R202, D215, R220, R221, R222, R223, R224, IC2, D206, R213, R214, D205, R242
- PB Board . . FBT, R1, R2

It is necessary to use a regulated DC power supply and a digital multimeter for this confirmation. Connect the digital multimeters to TP2 and IHV(1) on PA Board.

Receive a color bar signal and set CONTRAST and BRIGHTNESS controls to preset position. (manual button is OUT)

2. Confirm that the reading on the digital multimeter of TP2 on PA Board is between +31.0V and +33.5V.
3. If the reading on the digital multimeter of TP2 is more than +32.5V, 1MΩ ±1% 1/6 W (metal-film) should be mounted at the portion of R222 on PA Board. (Normally in this position no component is mounted.)
4. Short-circuit R213.
5. Connect a regulated dc power supply to IHV(1) through a diode. (for example, 1SS119).
6. Confirm that the reading on the digital multimeter of IHV(1) on PA Board is between -7.6V and -11.8V when the raster disappears.
7. If step 6 can not be perform, check that the mounted components are correct.

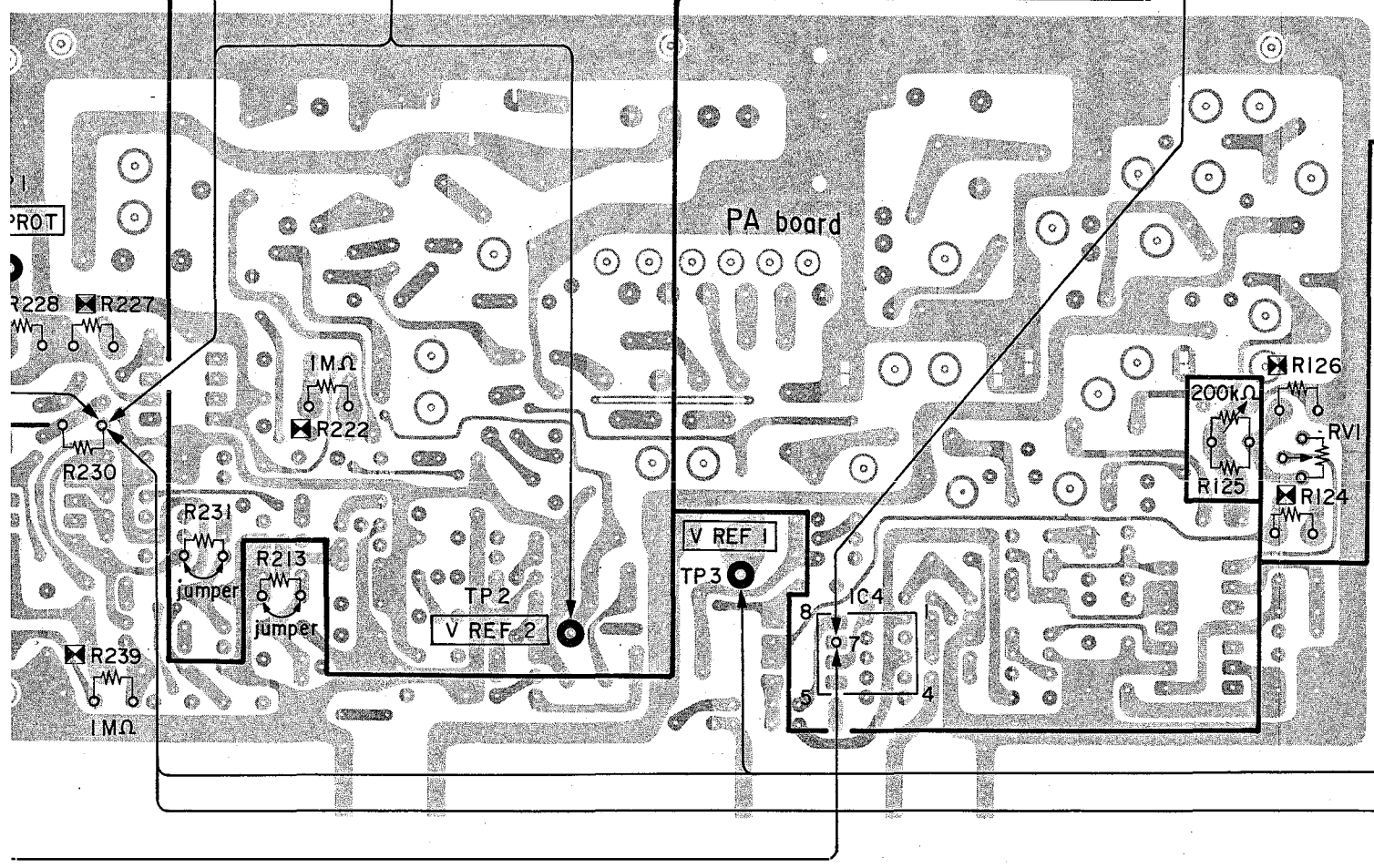
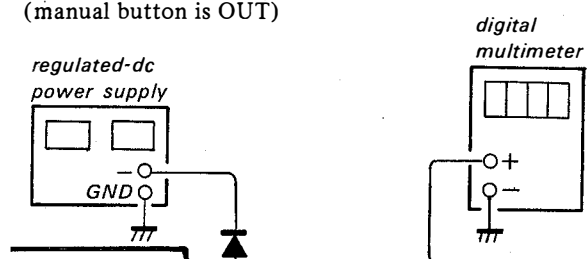

HIGH VOLTAGE REGULATOR CONFIRMATION

(R124, R126)

When replacing the following components (marked on the schematic diagram), make this adjustment.

- DCT Block
 - PA Board . . IC4, R123, R124, RV1, R125, R126, IC1, R203, R204, D216, R137, R138, R136

It is necessary to use an electrostatic voltmeter or equivalent for this adjustment. Connect the electrostatic voltmeter to the anode cap.

Even though an electrostatic voltmeter may not be used, connect digital multimeters to ⑦ pin of IC4 on PA Board.

Note: Use an electrostatic voltmeter which is calibrated, and which has $2 \times 10^9 \Omega$ or more input impedance.

example: ESH-27X or ESH-23X of the SINGER COMPANY

Use a digital multimeter which has 4 digit or more.

In case of using an electrostatic voltmeter

1. Receive a color bar signal and set CONTRAST and BRIGHTNESS controls to preset position. (manual button is out.)

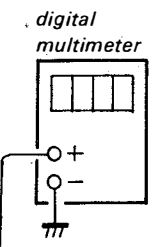

BEAM CURRENT PROTECTOR 2

(R239)

When replacing the following components (marked on the schematic diagram), make this confirmation.

- PA Board . . R203, R204, D216, R237, R238, R239, R240, R241, IC3, R231, R232, D204, R247
- PB Board . . FBT, R3, R4

It is necessary to use a regulated DC power supply and a digital multimeter for this confirmation.

Connect the digital multimeters to TP3 and IHV(1) on PA Board.

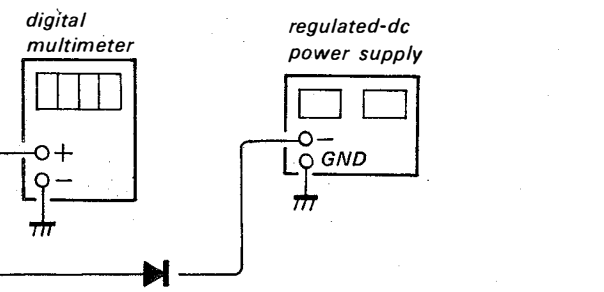

1. Receive a color bar signal and set CONTRAST and BRIGHTNESS controls to preset position. (manual button is OUT)
2. Confirm that the reading on the digital multimeter of TP3 on PA Board is between +31.0V and +33.5V.
3. If the reading on the digital multimeter of TP3 is more than +32.5V, 1MΩ ±1% 1/6 W (metal-film) should be mounted at the portion of R239 on PA Board. (Normally in this portion no component is mounted.)
4. Short-circuit R213.
5. Connect a regulated dc power supply to IHV(1) through a diode. (For example, 1SS119 etc.)
6. Confirm that the reading on the digital multimeter of IHV(1) on PA Board is between -7.6V and -11.8V when the raster disappears.
7. If step 6. can not be performed, check that the mounted components are correct.

4-7. CIRCUIT ADJUSTMENTS

- To make the following adjustments, unless otherwise specified, the controls knobs and switches shall be preset as described below.

FRONT PANEL (R)

- | | | |
|-----------------------------|--------------|-----------------|
| 1. INPUT selector | A | } HC board |
| 2. SYNC selector | INT | |
| 3. MODE selector | AUTO | } HG board (HD) |
| 4. CONTRAST MANUAL switch | .. PRESET | |
| 5. BRIGHTNESS MANUAL switch | .. PRESET | |
| 6. CHROMA MANUAL switch | ... PRESET | |
| 7. PHASE MANUAL switch | PRESET | |

FRONT PANEL (L)

- | | | |
|-------------------------------------|------------|------------|
| 8. SCAN MODE switch | | } HA board |
| <input type="checkbox"/> UNDER SCAN | NOR | |
| <input type="checkbox"/> H. DELAY | NOR | |
| <input type="checkbox"/> V. DELAY | NOR | |
| 9. SCREEN switch (R) | NOR | |
| 10. SCREEN switch (G) | NOR | |
| 11. SCREEN switch (B) | NOR | |
| 12. APT switch | NOR | |
| 13. BLUE ONLY switch | NOR | |
| 14. COMB/TRAP filter selector | TRAP | |

SUB CONTROL PANEL

- | | | |
|-----------------------------------|---------------|------------|
| 15. INPUT SELECT buttons | B | } HB board |
| 16. COLOR STANDARD buttons | .. PAL | |
| 17. FILTER switch | OFF | |
| 18. MATRIX switch | OFF | |
| 19. PAL/SECAM mode selector | ... D(L) | |
| 20. WHITE/OPERATE/SET UP selector | OPERATE | |
| 21. SPLIT SCREEN switch | OFF | |
| 22. CROSS HATCH switch | OFF | |
| 23. VITC switch | OFF | |
| 24. PIC. SET UP switch | OFF | |
| 25. AFC switch | 2m sec | } DA board |

FRONT PANEL (R)

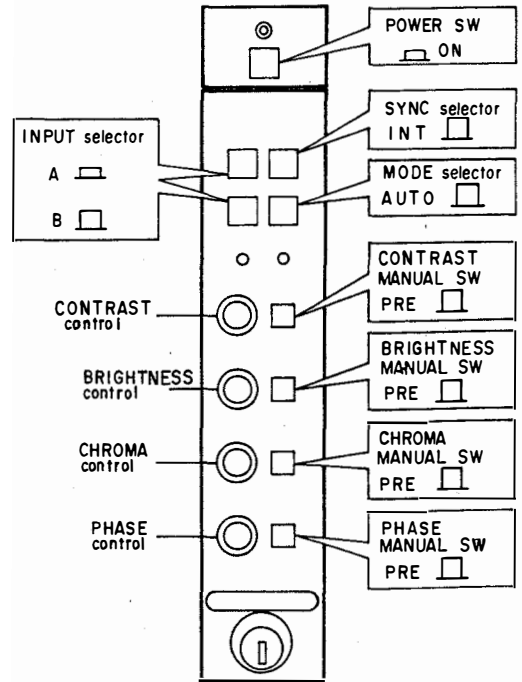

FRONT PANEL (L)

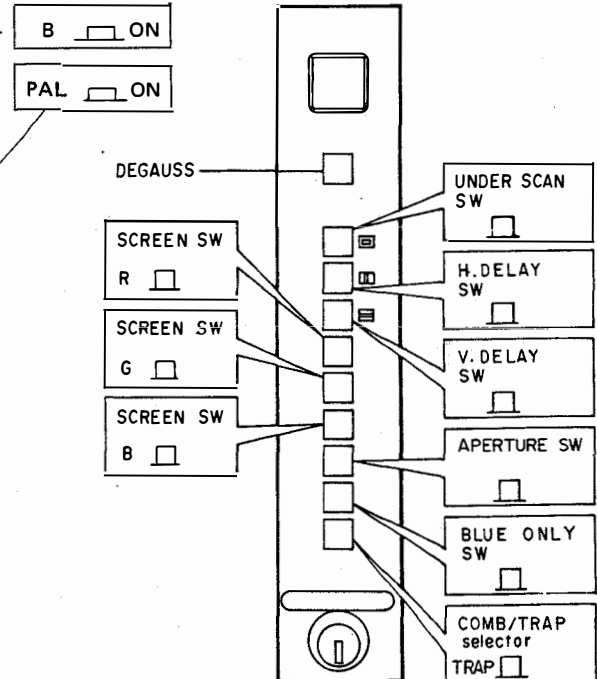

SUB CONTROL PANEL (HB board)

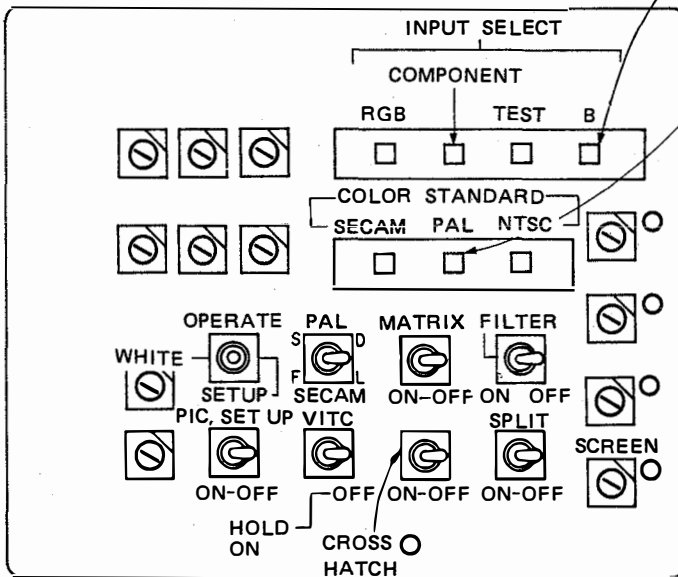

1. HB Board SUB CHROMA, SUB PHASE ADJUSTMENT

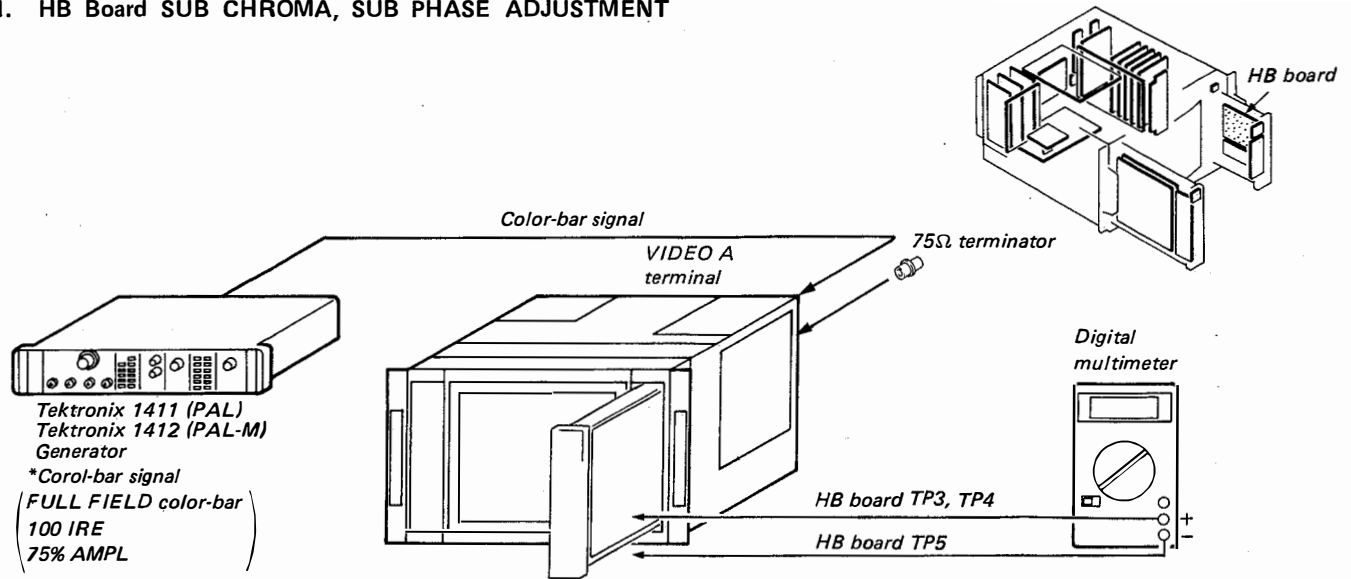

1. Connect a digital multimeter to the TP3 of HB board and TP5 (ground).
2. Adjust to -5.5V DC with RV3. (SUB CHROMA)
3. Connect a digital multimeter to the TP4 of HB board and TP5.
4. Adjust to 0V DC with RV4. (SUB PHASE) of HB board.

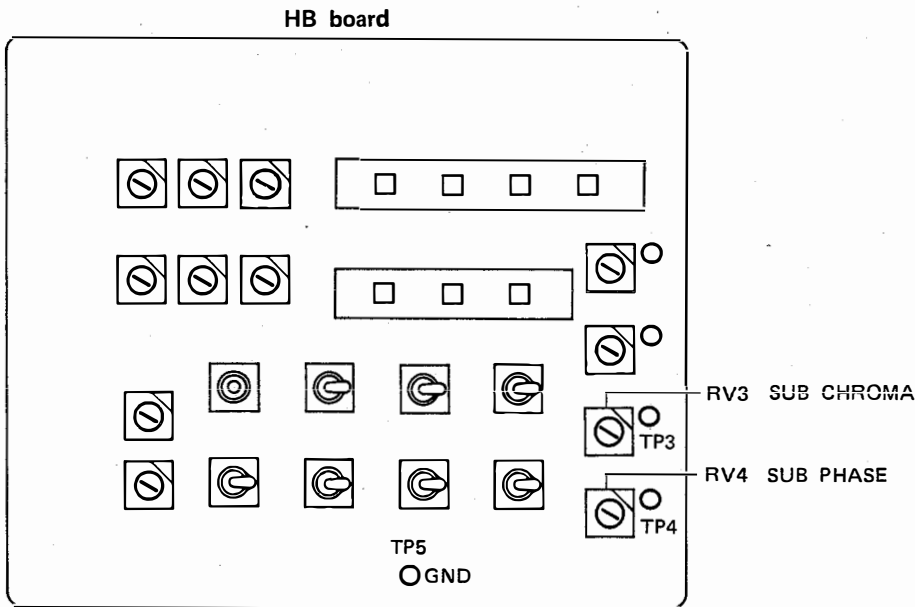

4. ADJUSTMENTS

2. BJ Board BRT PULSE ADJUSTMENT

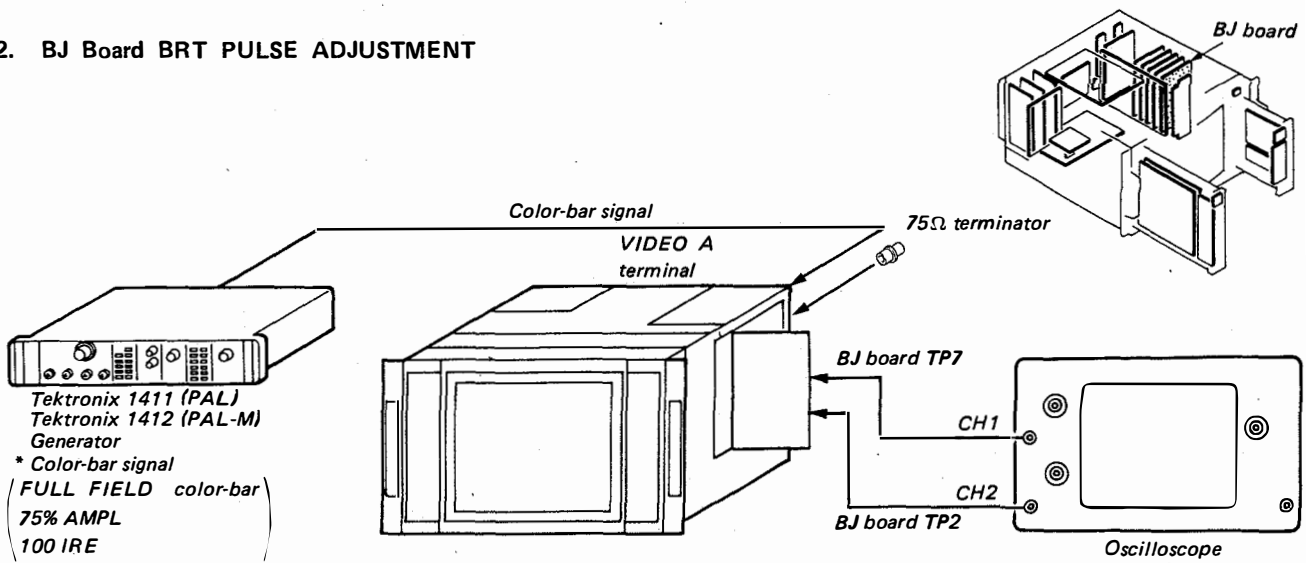

1. Input a color-bar signal to VIDEO A terminal of the set.
2. Connect an oscilloscope (CH1 probe) to the TP7 of BJ board and oscilloscope (CH2 probe) to the TP2 of BJ board.
3. Adjust RV7 to obtain the waveform on the oscilloscope as shown in Fig. 2-1.

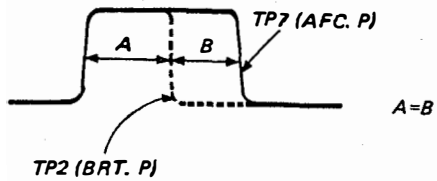
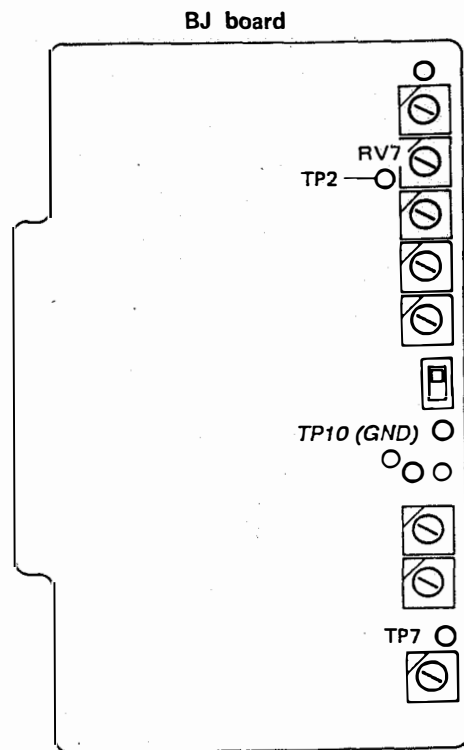
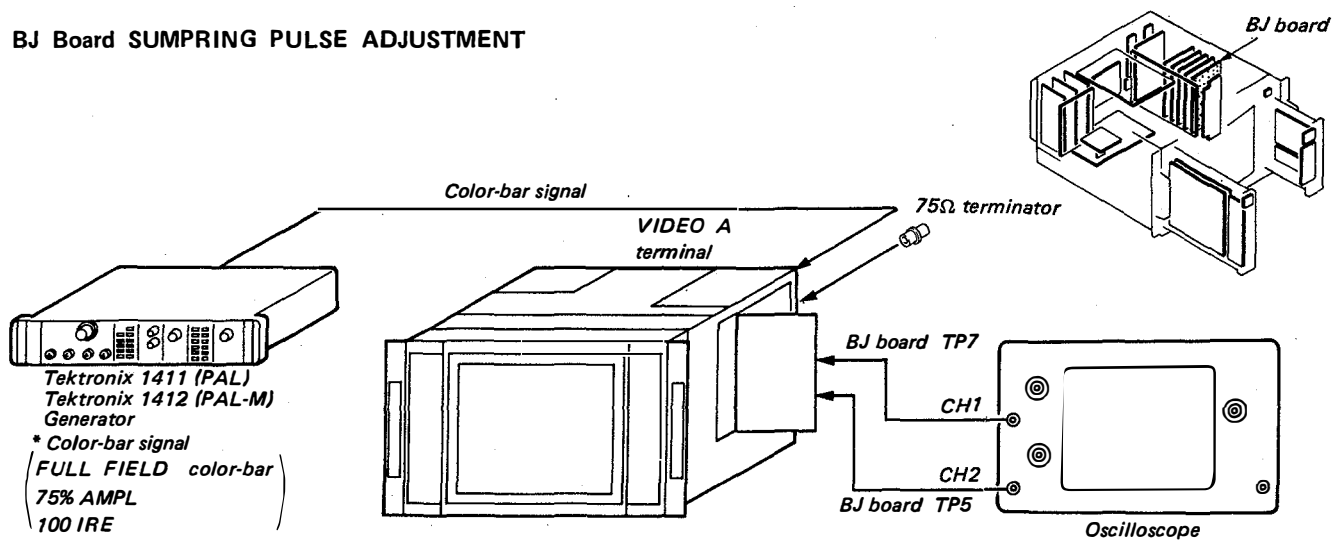

Fig. 2-1



BJ Board SUMPRING PULSE ADJUSTMENT



1. Input a color-bar signal to VIDEO A terminal of the set.
2. Connect an oscilloscope (CH 1 probe) to the TP7 of BJ board and Connect an oscilloscope (CH 2 probe) to the TP5 of BJ board.
3. Adjust RV5 to obtain the waveform on the oscilloscope as shown in Fig. 2-2.

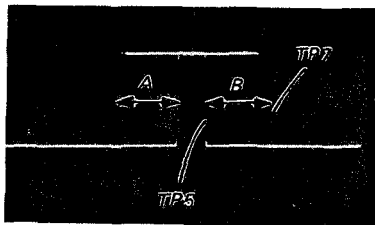
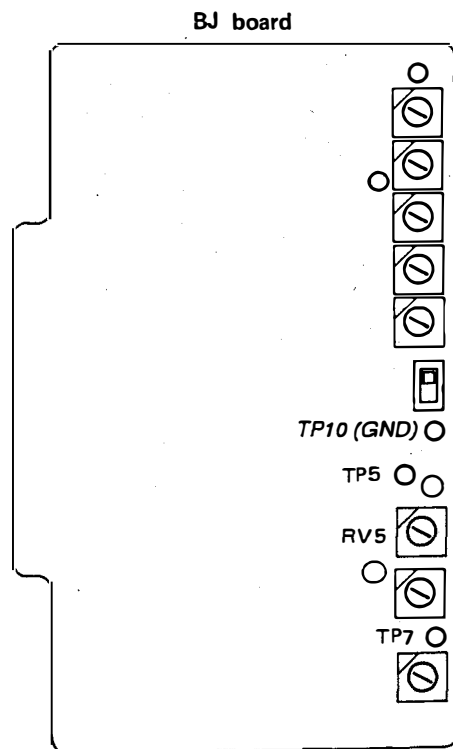
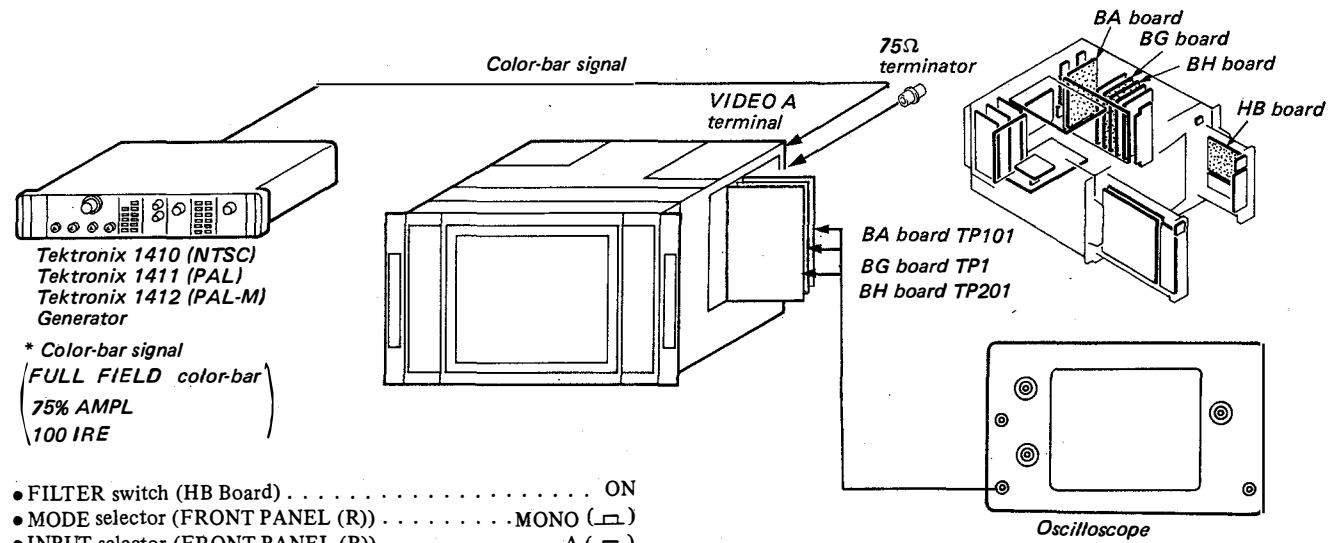

Fig. 2-2



3. EACH CHANNEL LEVEL ADJUSTMENT



- FILTER switch (HB Board) ON
- MODE selector (FRONT PANEL (R)) MONO ()
- INPUT selector (FRONT PANEL (R)) A ()
- COLOR STANDARD button (SUB CONTROL PANEL) PAL ()

BA board

1. Input a color-bar signal to VIDEO A terminal to the set.
2. Connect an oscilloscope to the TP101 of BA board.
3. Adjust to 1.0Vp-p with RV101 of BA board as shown in Fig. 3-1.

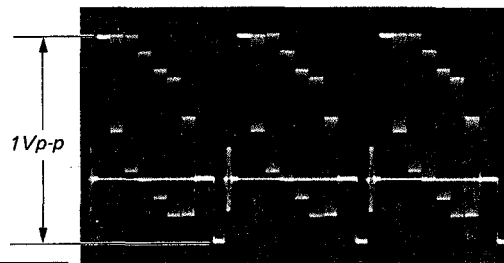

Fig. 3-1

BG board

4. Connect an oscilloscope to the TP1 of BG board.
5. Adjust to 1.0Vp-p with RV3 of BG board as shown in Fig. 3-1.
6. Connect an oscilloscope to the TP201 of BH board.

HB board

7. Adjust RV2 (SUB BRT) of HB board so that (A) (black level) is 0V DC as shown in Fig. 3-2.
8. Adjust RV1 (SUB CONT) of HB board so that (B) (100% white level) is -0.7V DC as shown in Fig. 3-2.

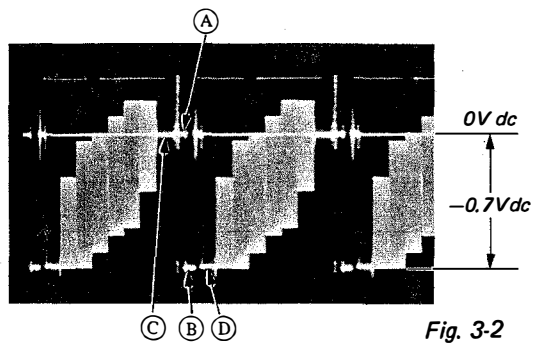

Fig. 3-2

- (A) Black level
- (B) 100% White level
- (C) 0 IRE level
- (D) 100 IRE level

BH board

9. S2 (BH Board) 0 IRE
Adjust RV1 of BH board so that the (C) (0 IRE level) coincides with (A) (Black level) as shown in Fig. 3-3.
10. Adjust RV3 of BH board so that the (D) (100 IRE level) coincides with (B) (100% white level) as shown in Fig. 3-3.

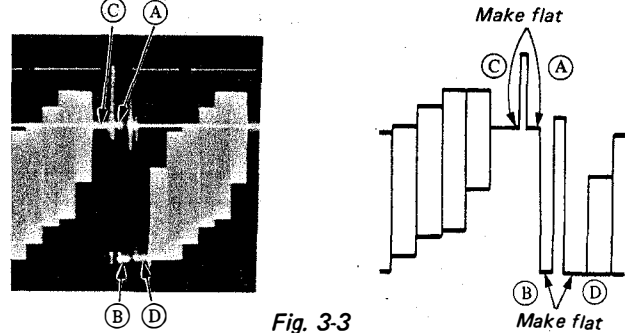

Fig. 3-3

BH board

11. S2 (BH Board) 7.5 IRE
COLOR STANDARD button NTSC
Input a NTSC color-bar signal (with 7.5% SET UP) to VIDEO A terminal to the set.
12. Adjust RV2 of BH board so that the (E) (7.5 IRE level) coincides with (A) (Black level) as shown in Fig. 3-4.
13. S2 (BH Board) 0 IRE

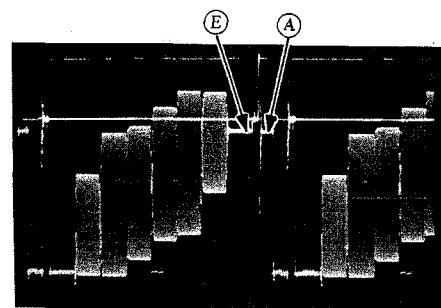
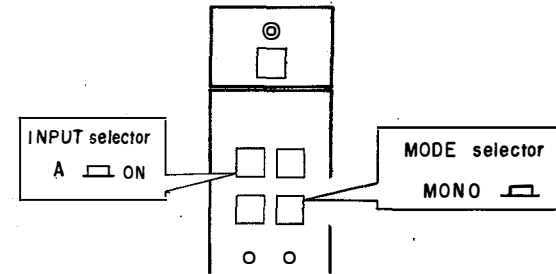
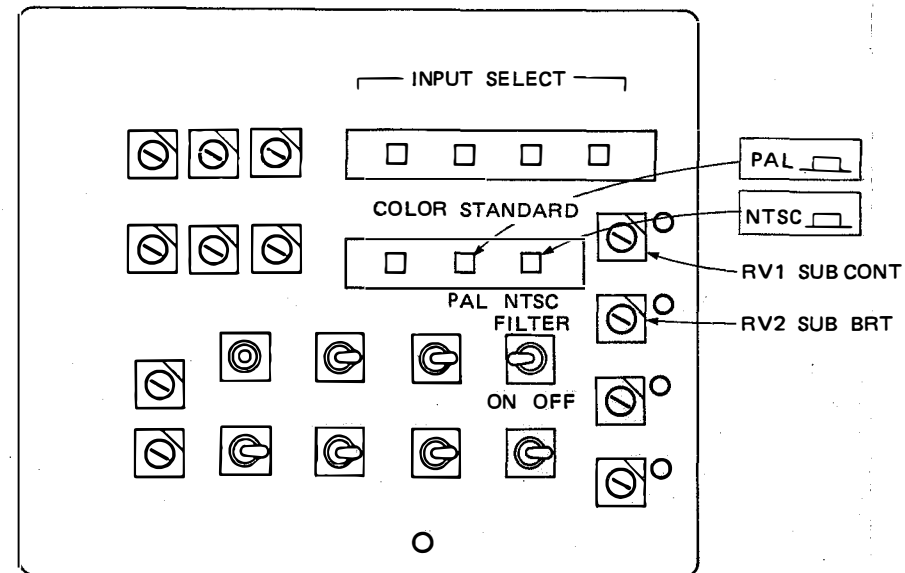

Fig. 3-4

FRONT PANEL (R)



HB board



BG board

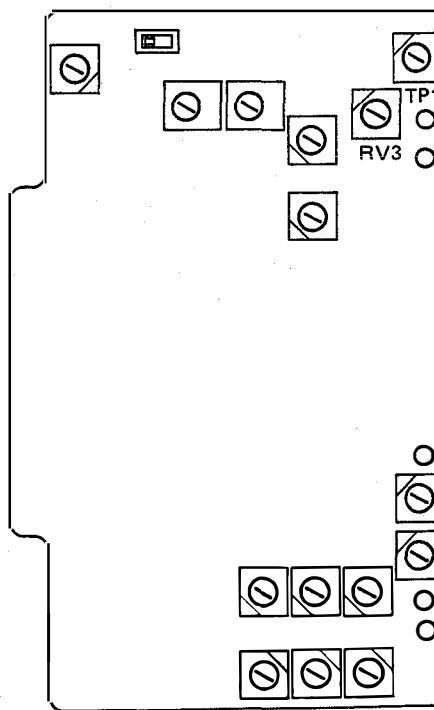

BA board

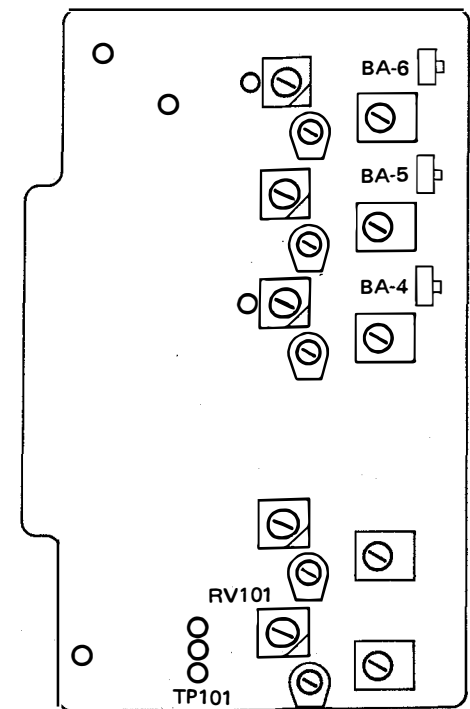

BH board

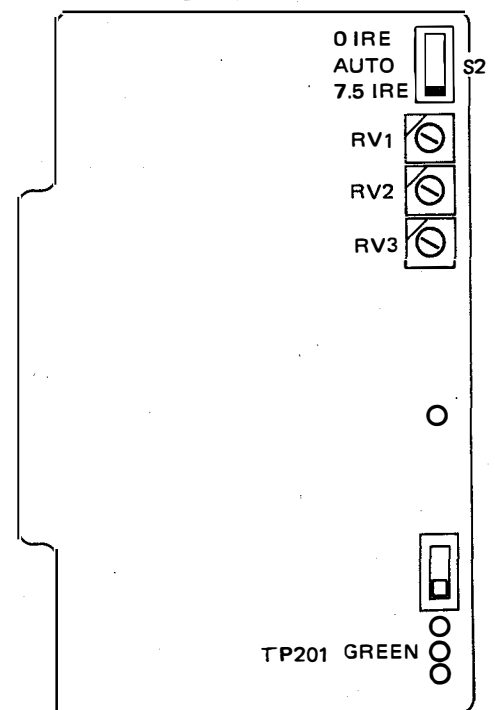

BA board

13. Input a color-bar signal to VIDEO B terminal of the set.
 - INPUT selector (FRONT PANEL (R)) B ()
 - SYNC selector (FRONT PANEL (R)) EXT ()
 - INPUT SELECT buttons (SUB CONTROL PANEL (R)) RGB ()

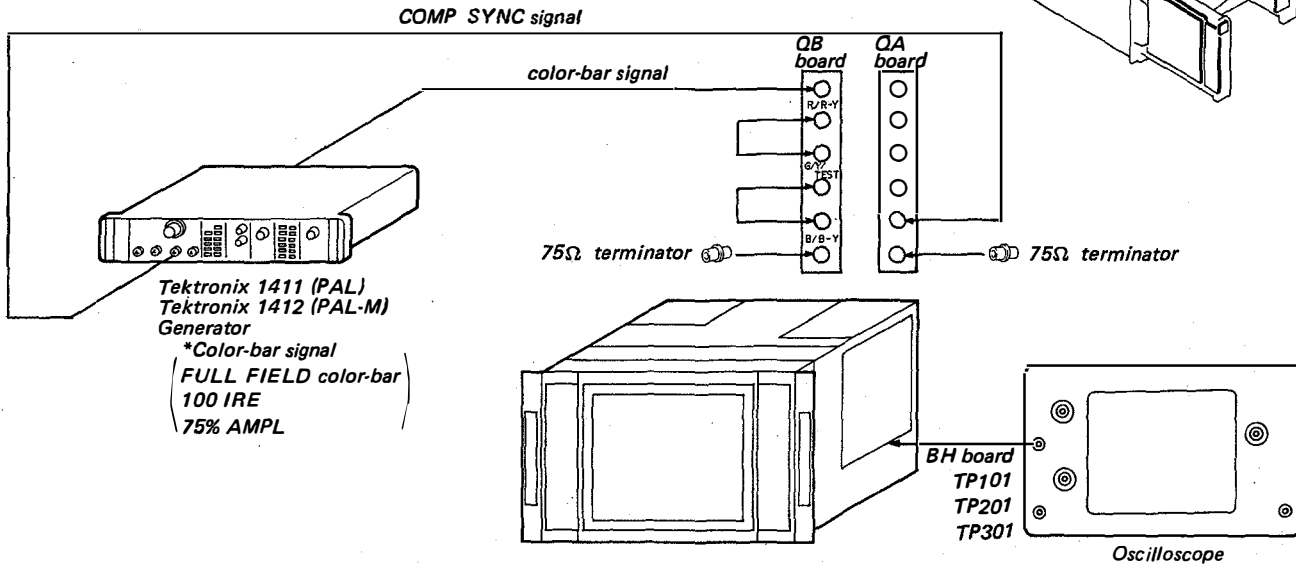

14. Connect an oscilloscope to TP101 of BH board.
15. Adjust RV401 of BA board so that the ① (100 IRE level) coincides with ② (100% white level) as shown in Fig. 3-5.
16. Connect an oscilloscope to TP201 of BH board.
17. Adjust RV501 of BA board so that the ① (100 IRE level) coincides with ② (100% white level) as shown in Fig. 3-5.
18. Connect an oscilloscope to TP101 of BH board.
19. Adjust RV601 of BA board so that the ① (100 IRE level) coincides with ② (100% white level) as shown in Fig. 3-5.

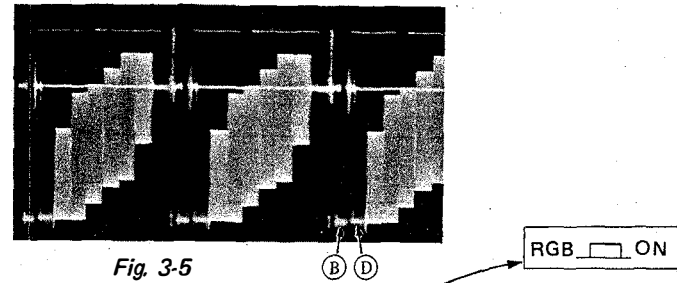

BH board

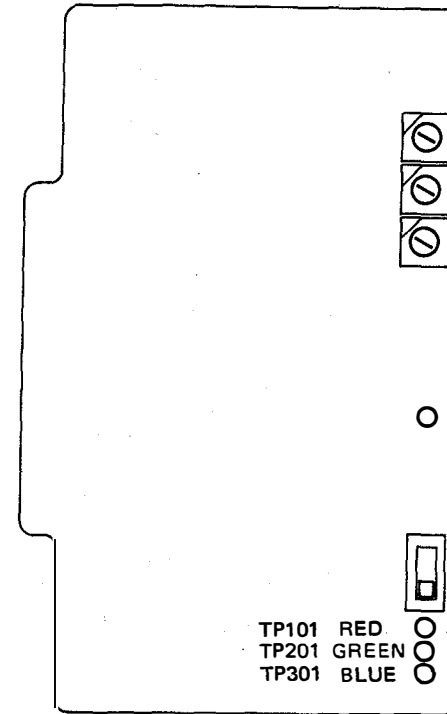

FRONT PANEL (R)

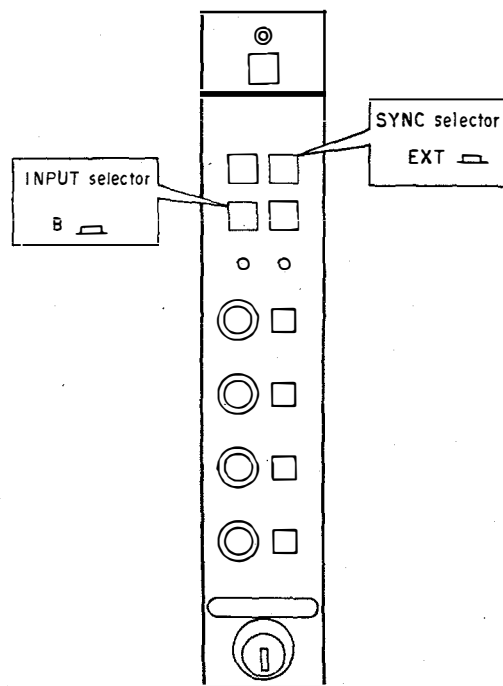

HB board

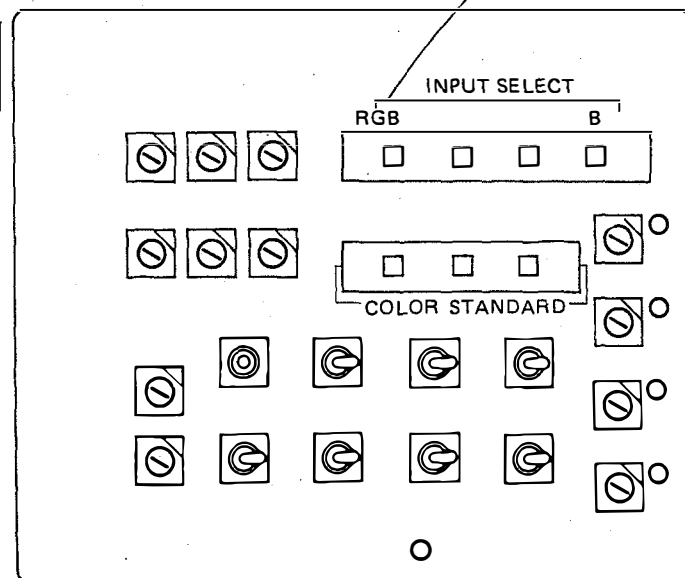

BA board

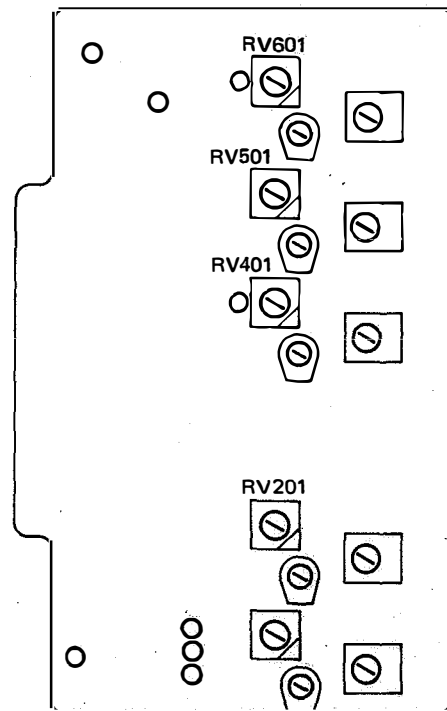

4. BA Board INPUT CIRCUIT FREQUENCY CHARACTERISTIC ADJUSTMENT

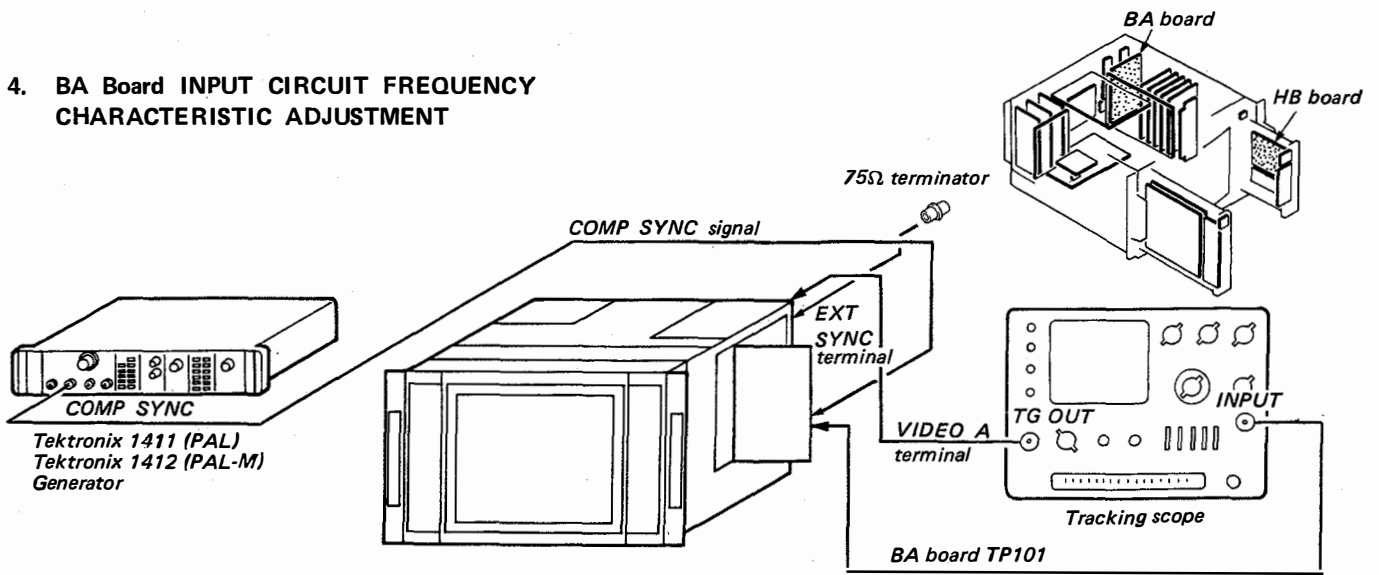

Fig. 4-1

- Complete the connection as shown in Fig. 4-1.
 - INPUT selector A (A)
 - SYNC selector EXT (EXT)
 - CONTRAST control Minimum
 - BRIGHTNESS control Minimum
- Adjust CV101 so that minimum as shown in Fig. 4-2.

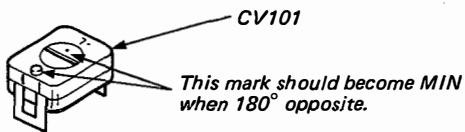

Fig. 4-2

- Adjust output waveform peak to 12MHz with CV102 of the BA board as shown in Fig. 4-3.

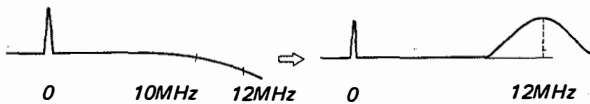

Fig. 4-3

- Adjust CV101 of the BA board so that the output waveform becomes flat in a range of 0 to 10MHz as shown in Fig. 4-4.

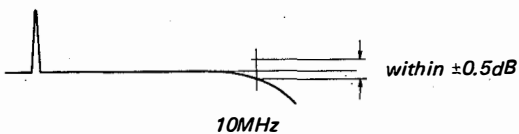
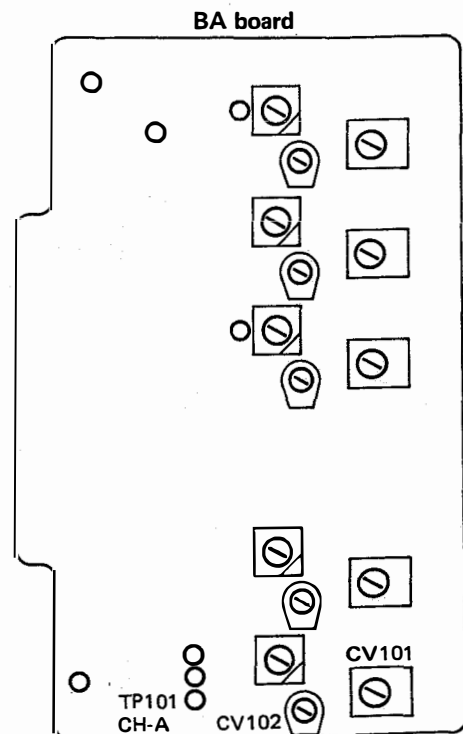
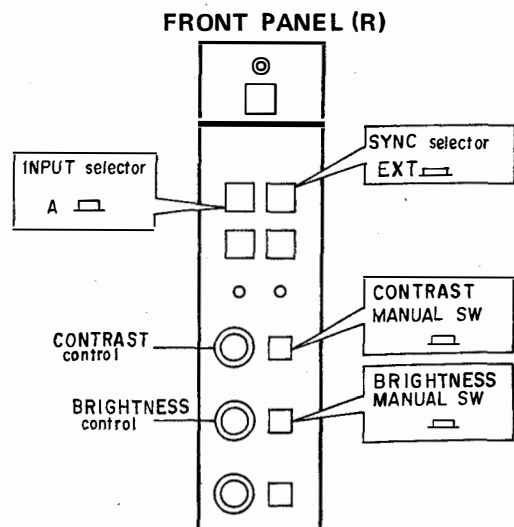

Fig. 4-4



5. In the same way, perform the adjustment for B CH, under the following conditions.

INPUT	INPUT selector (FRONT PANEL (A))	INPUT SELECT buttons (SUB CONTROL PANEL)	TP (BA board)	CV (BA board)
B	B	B	TP201	CV201, 202
R/R-Y	B	RGB	TP401	CV401, 402
G/Y/TEST	B	RGB	TP501	CV501, 502
B/B-Y	B	RGB	TP601	CV601, 602

FRONT PANEL (R)

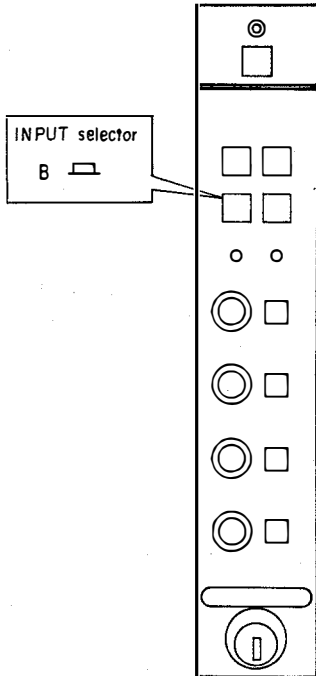

BA board

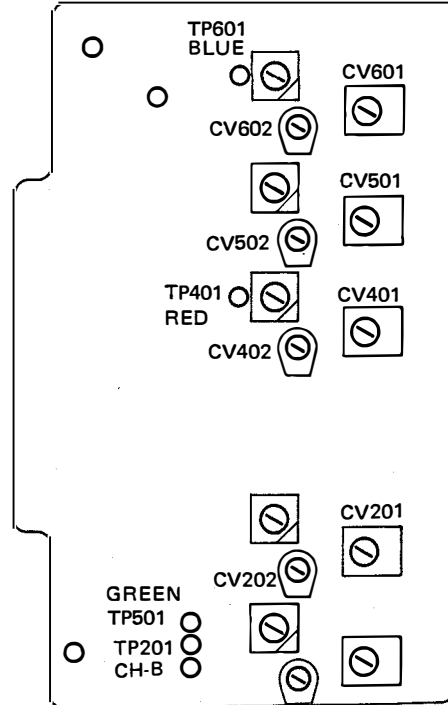

HB board

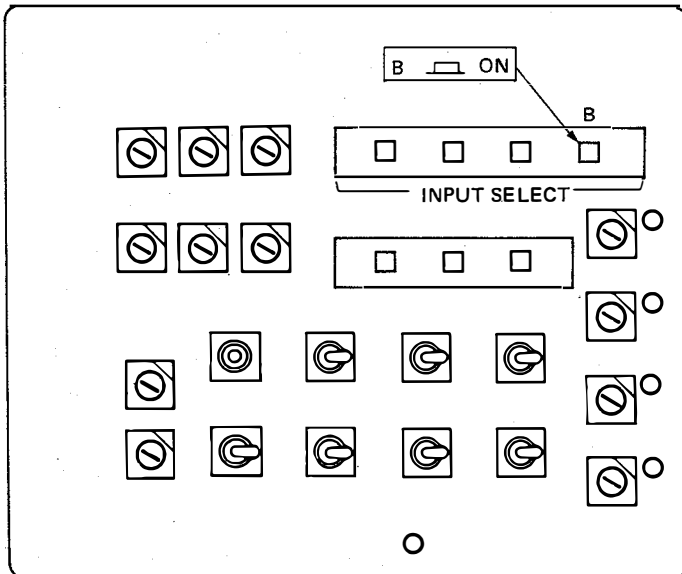

5. BG BOARD FREQUENCY CHARACTERISTIC ADJUSTMENT

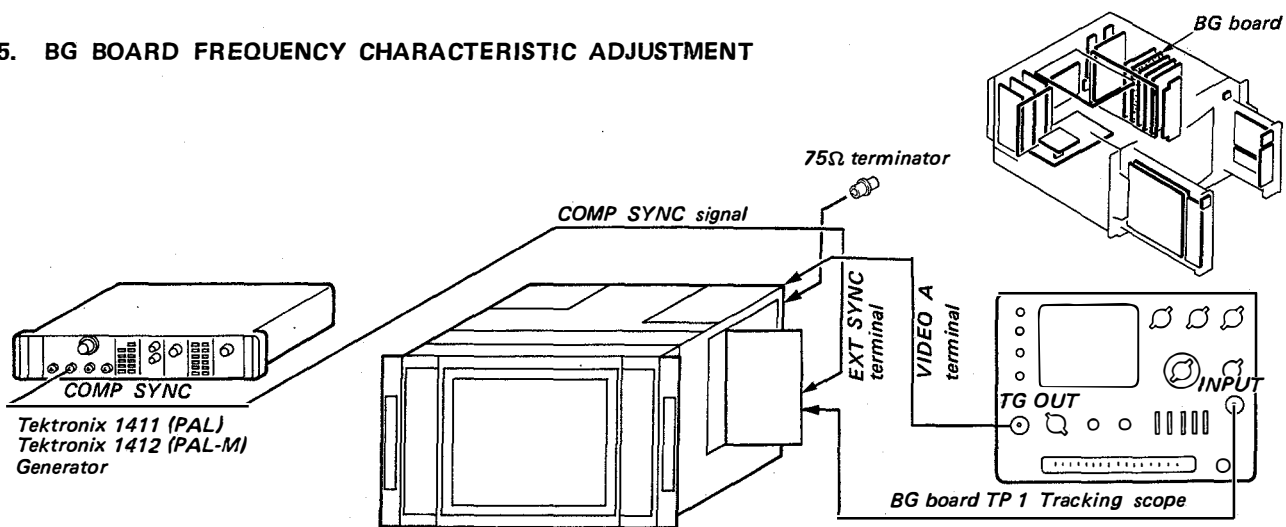

Fig. 5-1

- Complete the connections as shown in Fig. 5-1.
 - INPUT selector (FRONT PANEL (R)) A ()
 - SYNC selector (FRONT PANEL (R)) EXT ()
 - CONTRAST control Minimum
 - BRIGHTNESS control Minimum
 - S1 (BG Board) 4.5MHz (6.5)
- Adjust RV1, CV2 and CV3 of the BG board so that the output waveform becomes flat in a range of 0 to 10MHz as shown in Fig. 5-2. (within $0 \pm 0.5\text{dB}$)

*Waveform movement by RV1, CV2, CV3

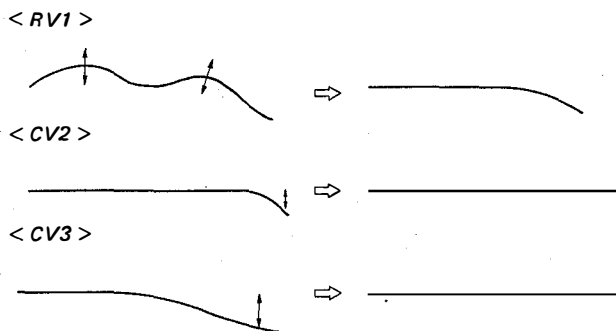

Fig. 5-2

- Adjust with RV2 (BG board) to the position in which the APT (Fig. 5-3.) begins to become effective.

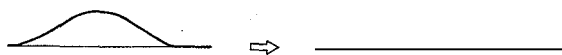
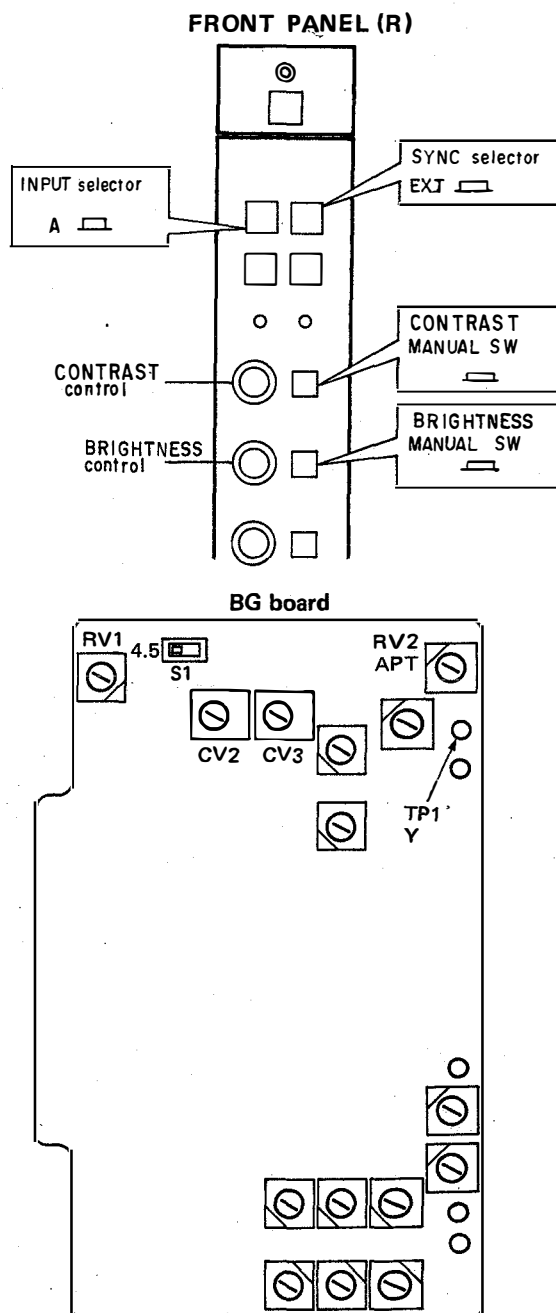

Fig. 5-3



6. COMPONENT INPUT LEVEL ADJUSTMENT

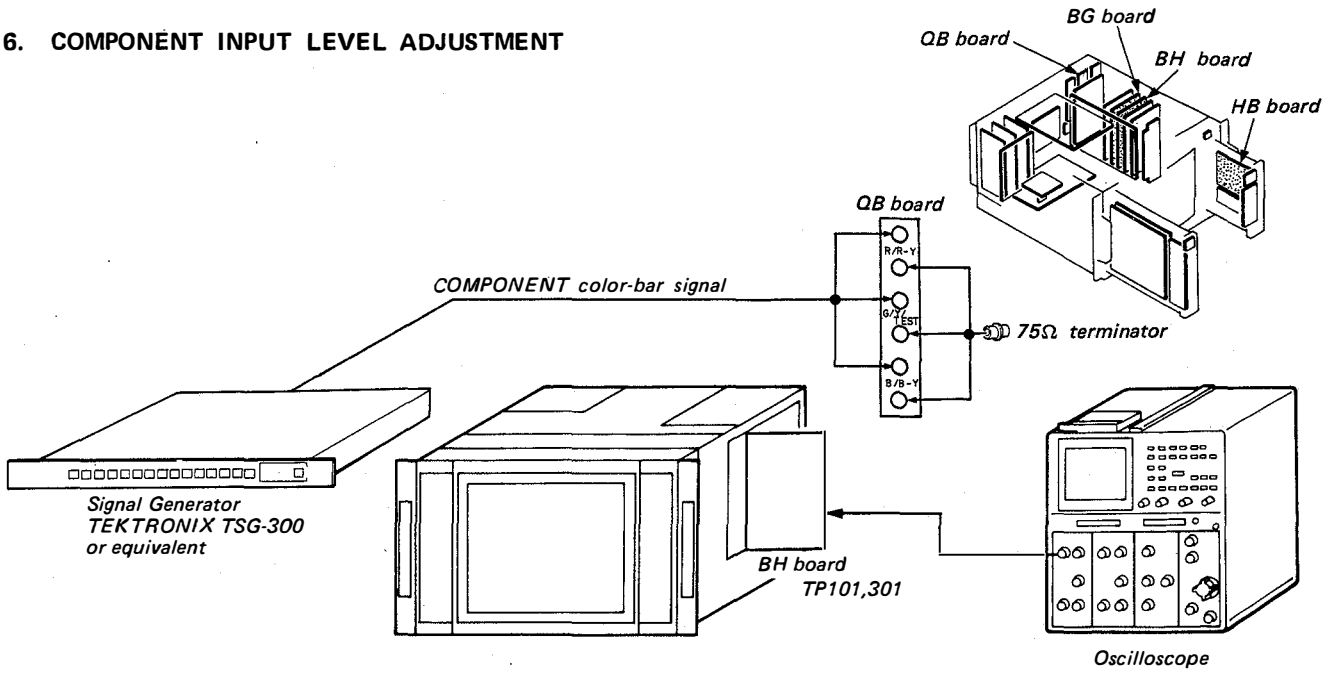

Fig. 6-1

1. Complete the connections as shown in Fig. 6-1.
 - INPUT selector B (FRONT PANEL (R))
 - INPUT SELECT buttons (RIGHT SIDE DRAWER) (HB board) COMPONENT
2. Connect an oscilloscope to the TP-101 of BH board.
3. Adjust RV21 of BG board so that the output waveform becomes flat. (Fig. 6-2)

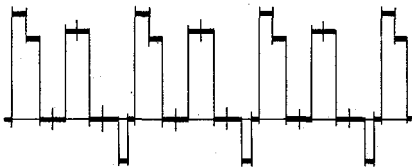

Fig. 6-2

4. Connect an oscilloscope to the TP301 of BH board.
5. Adjust RV22 of BG board so that the input waveform becomes flat. (Fig. 6-3)

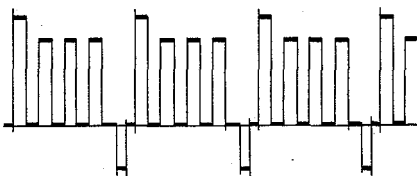
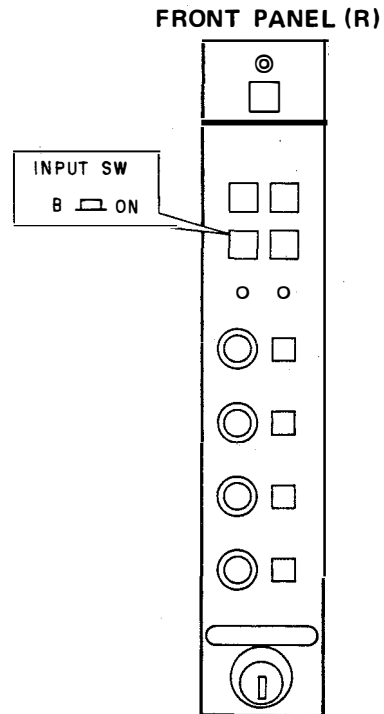
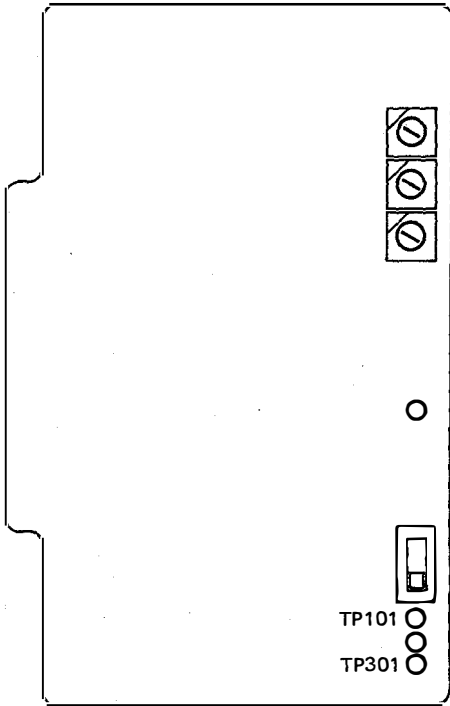

Fig. 6-3



BH board



BG board

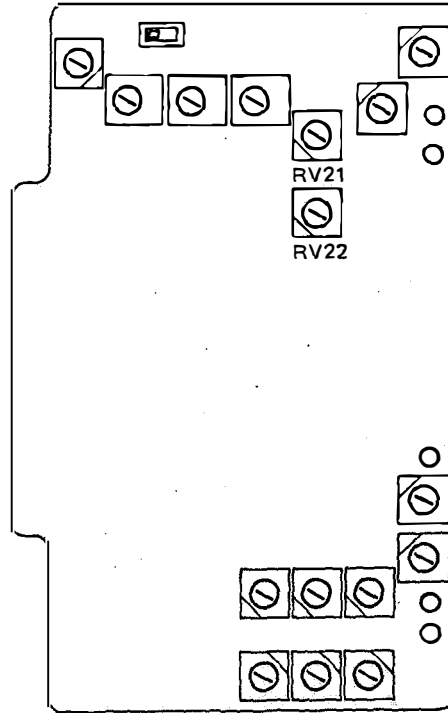

RIGHT SIDE DRAWER (HB board)

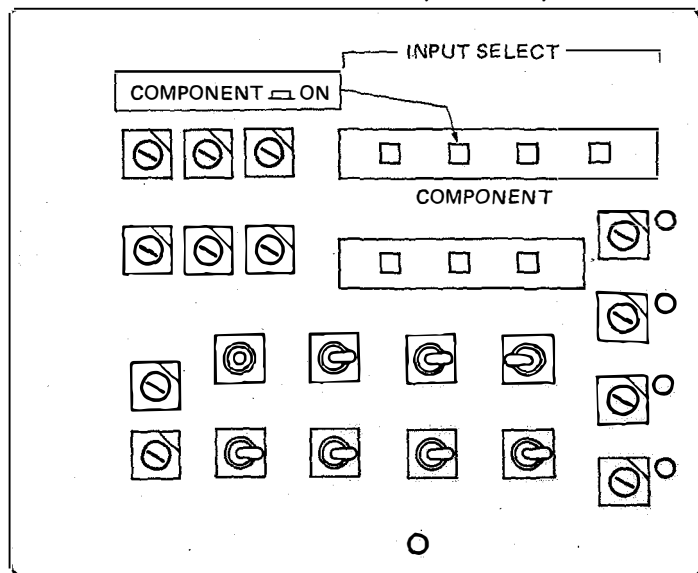

7. BJ Board BURST GATE PULSE ADJUSTMENT

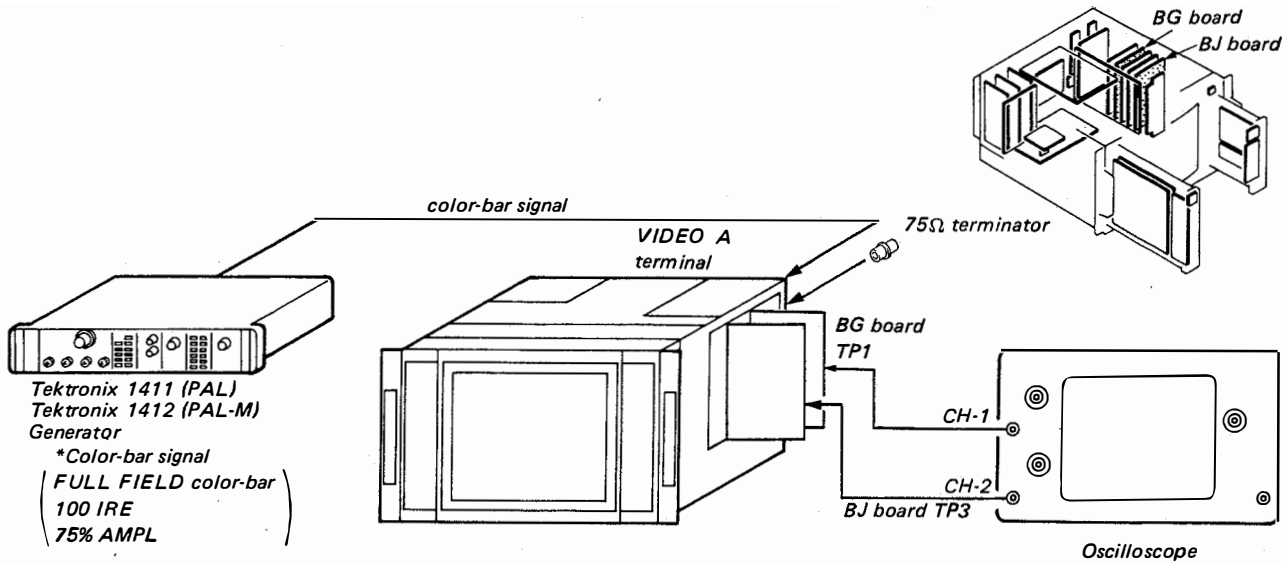

1. Input a color-bar signal to the VIDEO A terminal of the set.
2. Connect an oscilloscope (CH-1 probe) to the TP1 of BG board and connect an oscilloscope (CH-2 probe) to the TP3 of BJ board.
3. Adjust RV8 of BJ board so that the A width is $4.3\mu\text{s}$ as shown in Fig 7-1.

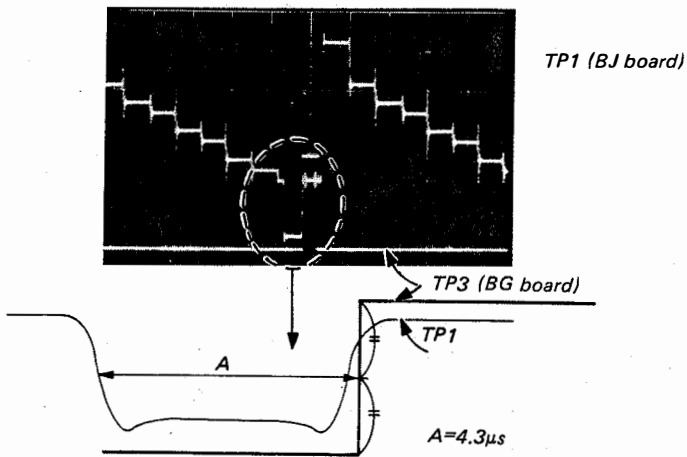

* Adjust (A), from SYNC fall to B.G.P. (BURST GATE PULSE) rise, to $4.3\mu\text{s}$.

Fig. 7-1

4. Adjust RV4 of BJ board so that the burst gate pulse width is $3.9\mu\text{s}$ as shown in Fig. 7-2.

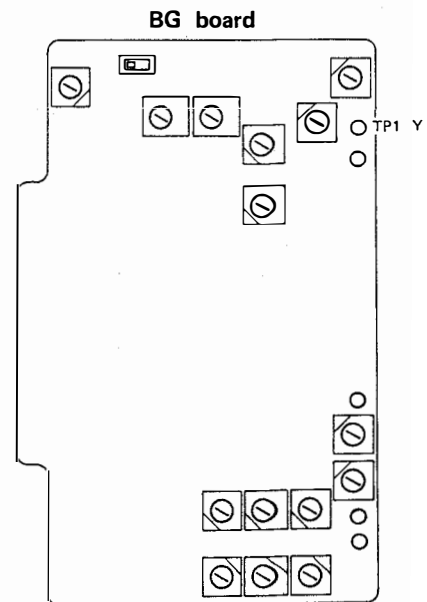
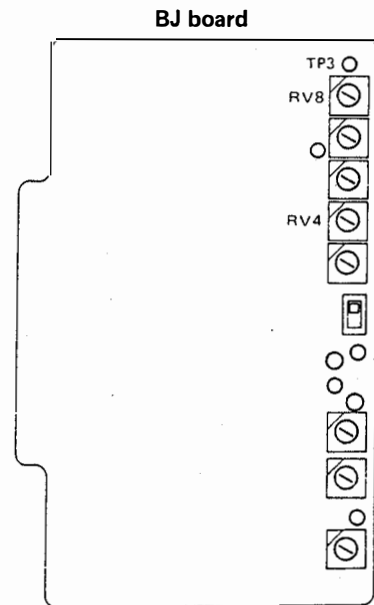
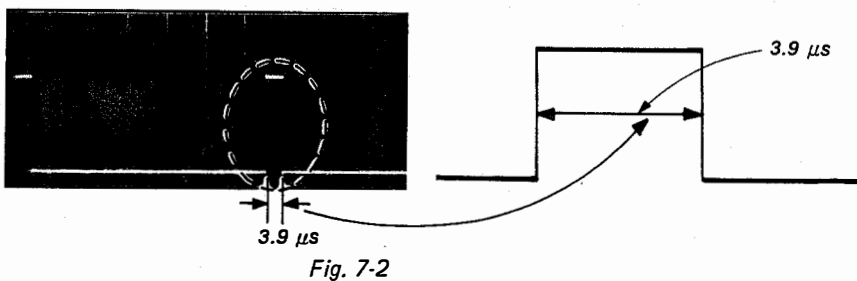

8. BD (PAL) OR BM (PAL-M) BOARD BPF ADJUSTMENT

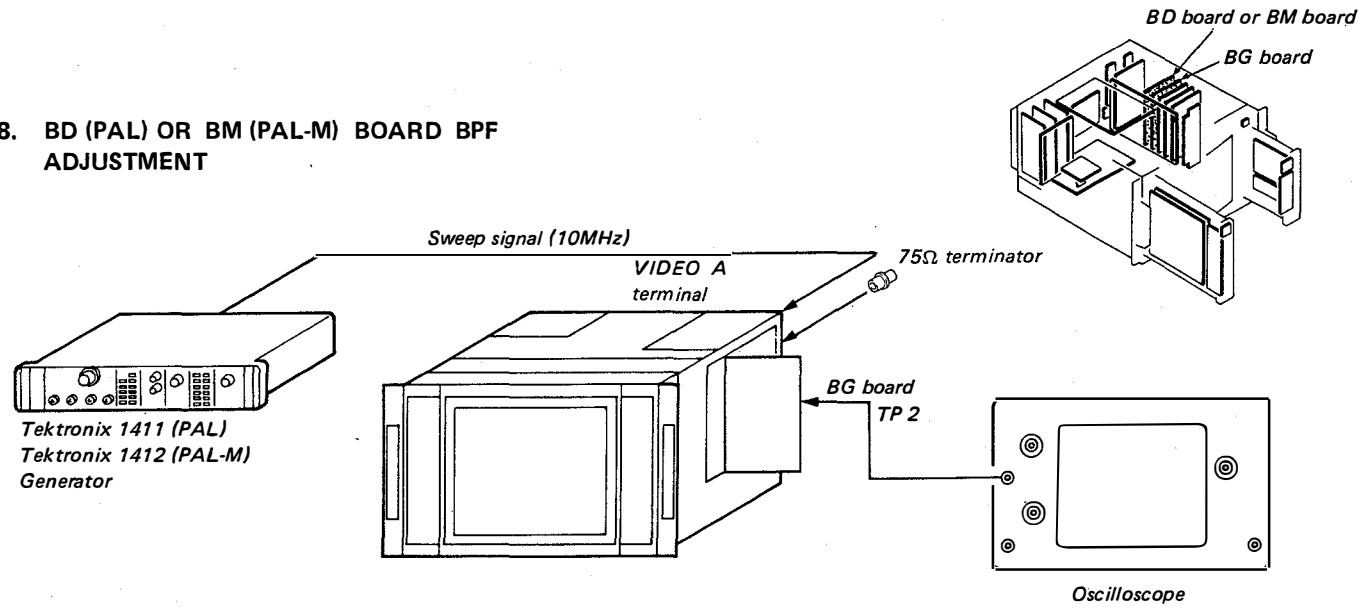

* Set the PAL switch of the BVM-1410P or 1410PM to the S position.

1. Input SWEEP signal (10MHz) to the VIDEO A terminal of the set.
2. Connect an oscilloscope to the TP2 on the BG board.
3. Make the V/div of oscilloscope into VARIABLE, and match the upper section of waveform to 7 div as shown in Fig. 8-1.

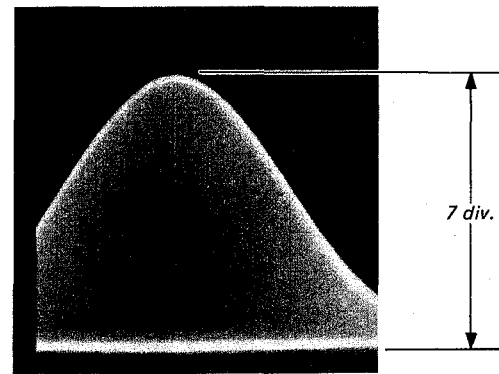
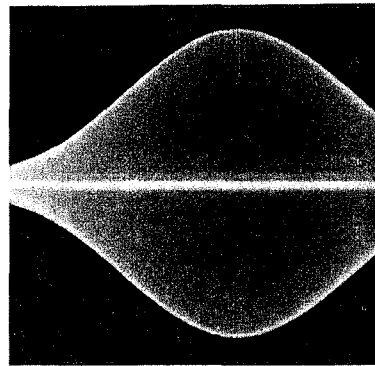

Fig. 8-1

4. Adjust L3 on the BD board so that A is equal to B as shown in Fig. 8-2.

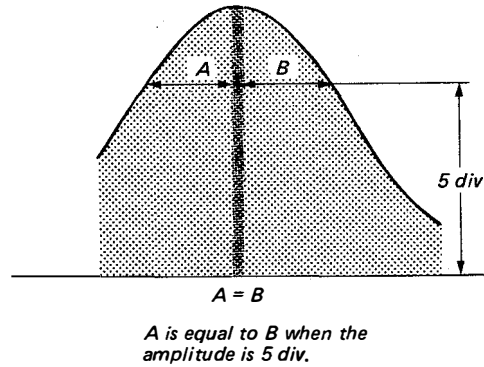
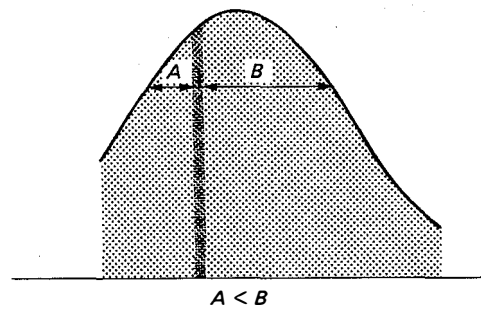
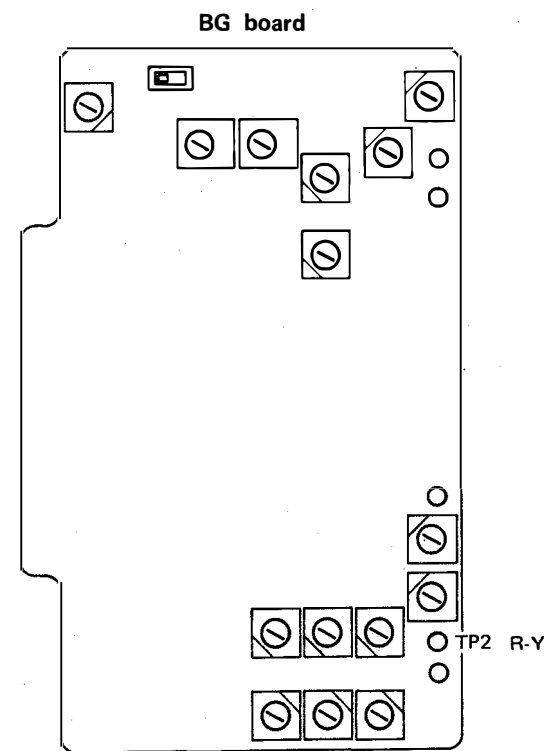
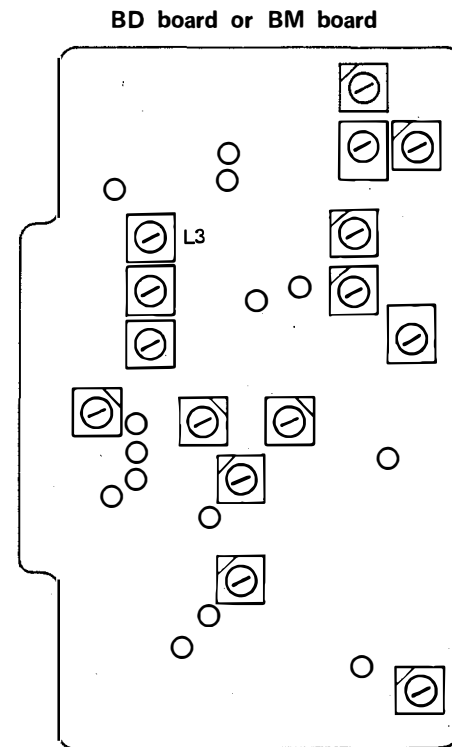

Fig. 8-2



9. BD (PAL) OR BM (PAL-M) BOARD PHASE SHIFT ADJUSTMENT

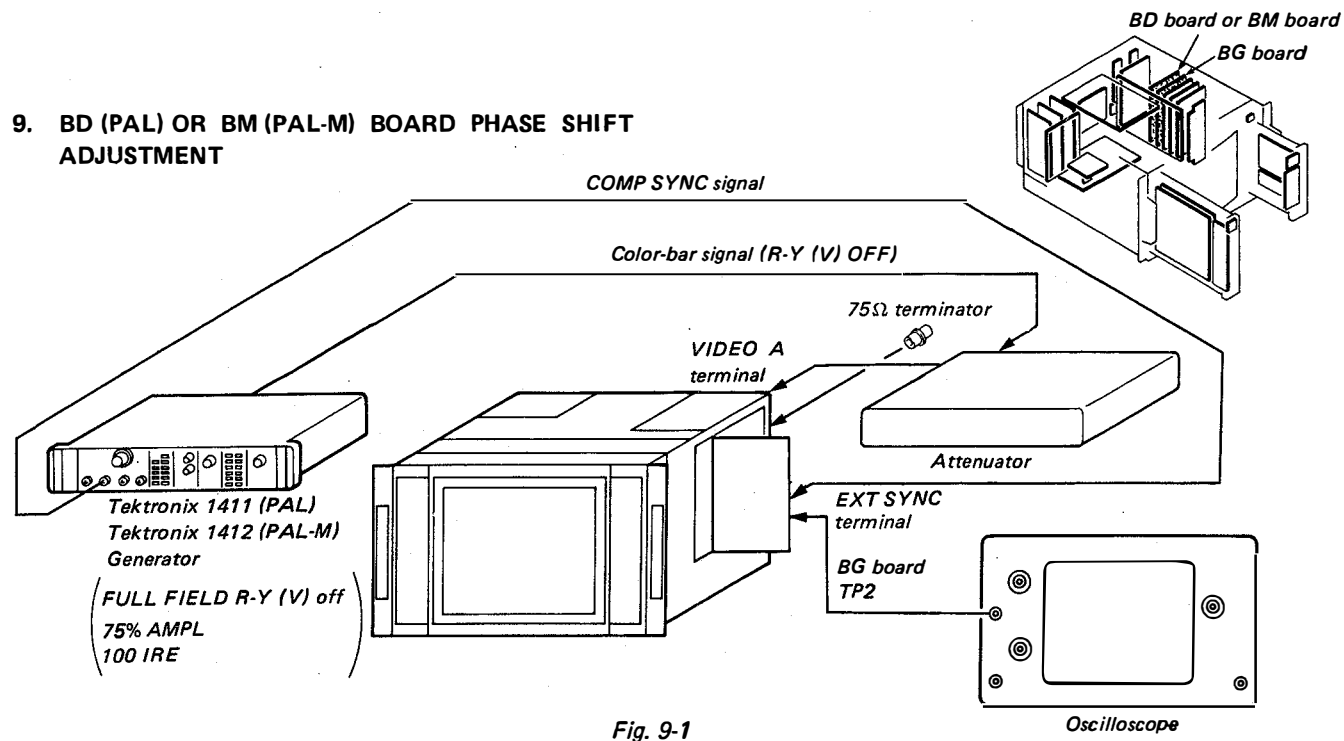

Fig. 9-1

* Set the PAL switch of the BVM-1410P or 1410PM to the S position and RV2, CV1, CV2 on the BD or BM board to mechanical midposition.

1. Complete the connection as shown in Fig. 9-1.
 - INPUT selector (FRONT PANEL (R)) ... A ()
 - SYNC selector (FRONT PANEL (R)) ... EXT ()
2. Connect an oscilloscope to the TP2 on the BG board.
3. Make the waveform flat with the PHASE control of front panel (R) as shown in Fig. 9-2.

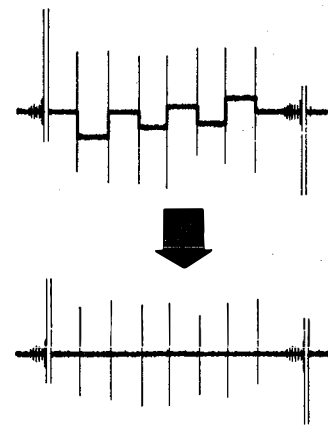
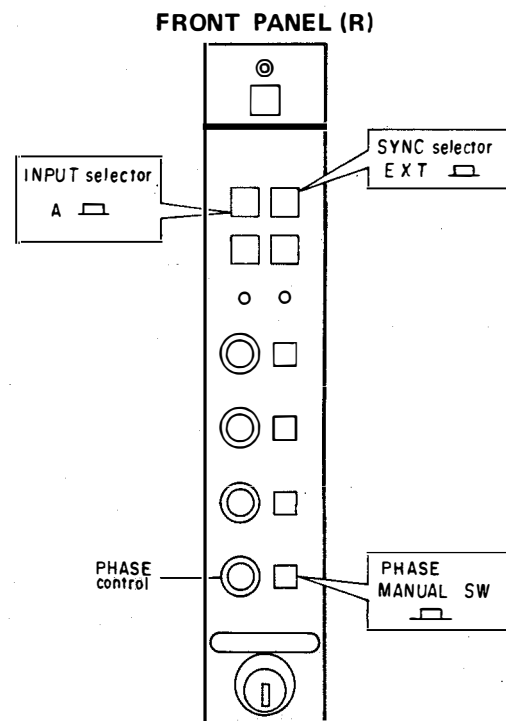
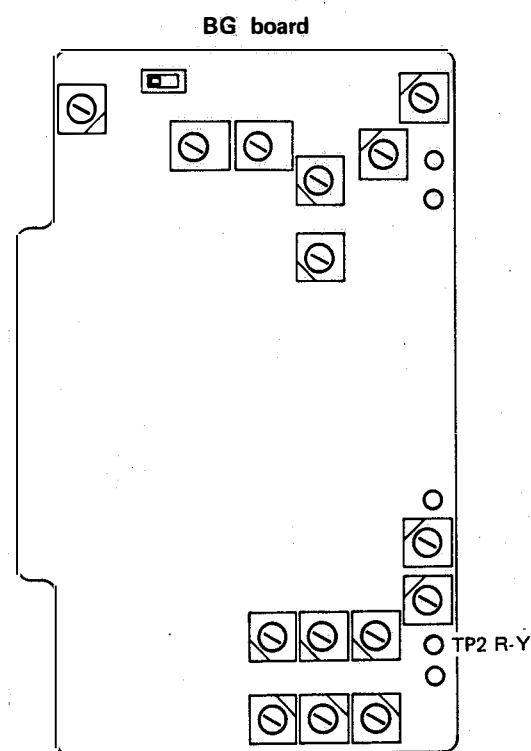
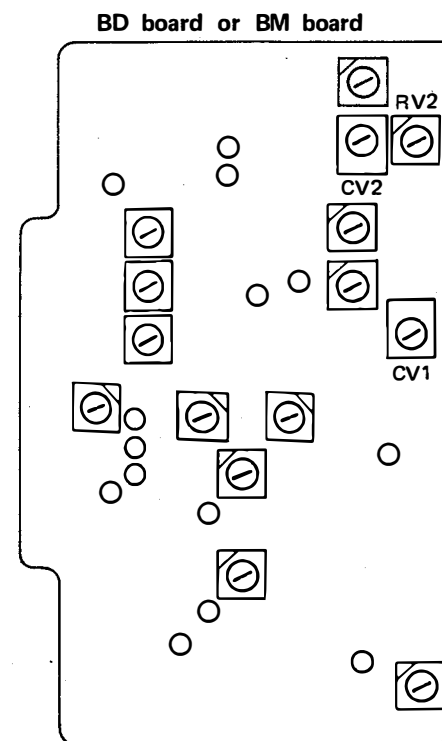

Fig. 9-2



4. Attenuate the signal by 10dB by using attenuator.
5. Adjust RV2 on the BD or BM board so that the output waveform becomes flat as shown in Fig. 9-2.
6. Restore the attenuator to 0dB.
7. Repeat the steps 3 to 5.



10. BD BOARD 4.43MHz (PAL) or BM BOARD 3.58MHz (PAL-M) fo ADJUSTMENT

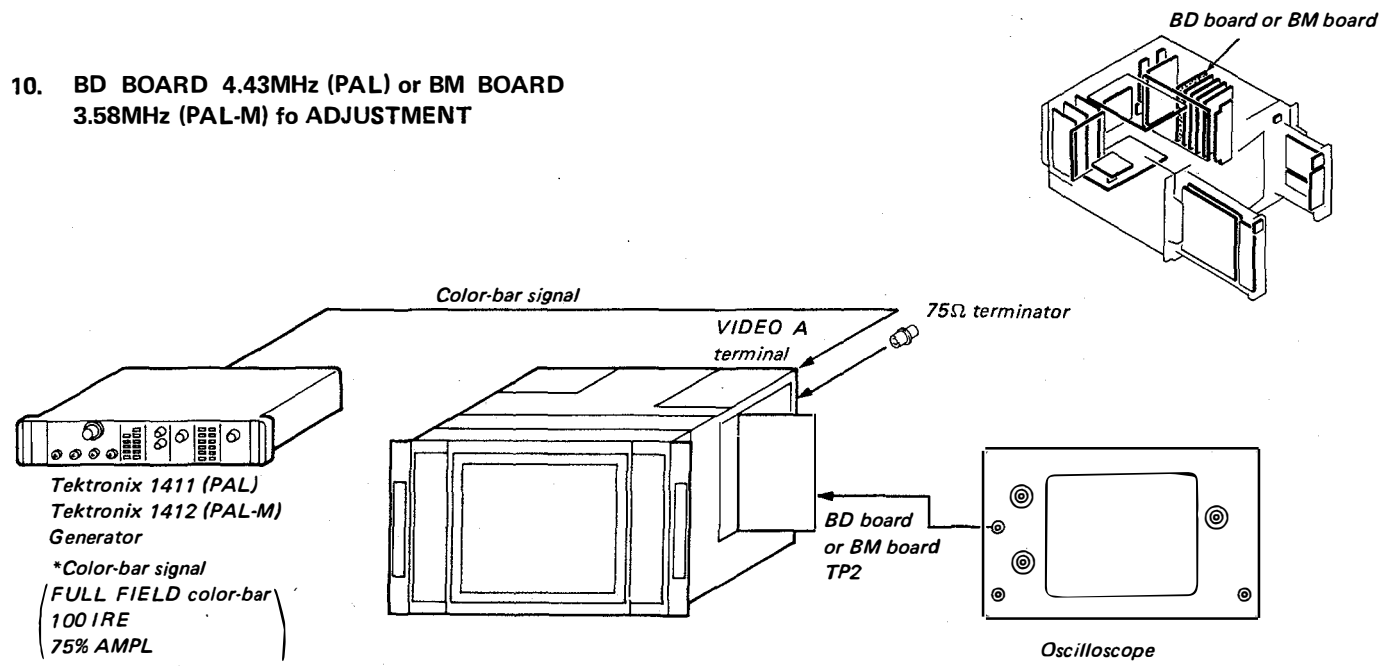

1. Input color-bar signal to the VIDEO A terminal of the set.
2. Connect an oscilloscope to the TP2 of BD or BM board.
3. Short-circuit between TP11, 12 of BD or BM board with a jumper wire.
4. Adjust CV2 of BD or BM board so that the output waveform is shifted slowly as shown in Fig. 10-1.
5. Turn off the power of this monitor, and disconnect TP11, 12 of BD or BM board.

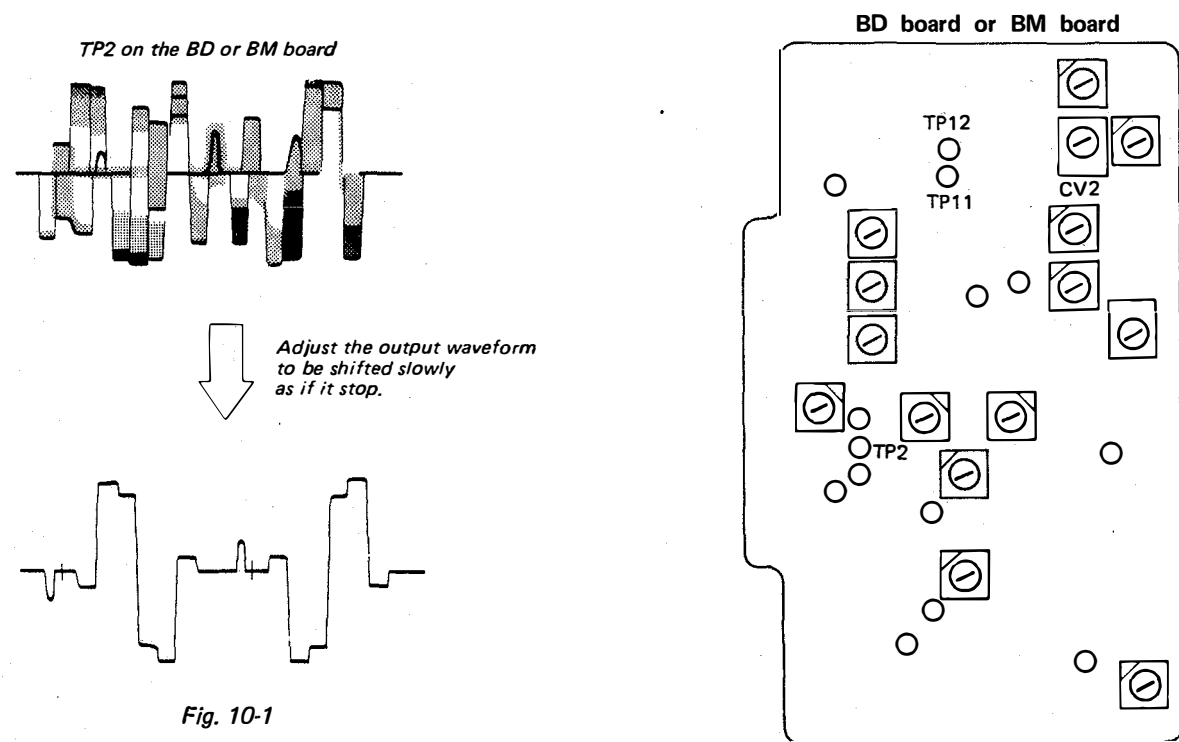
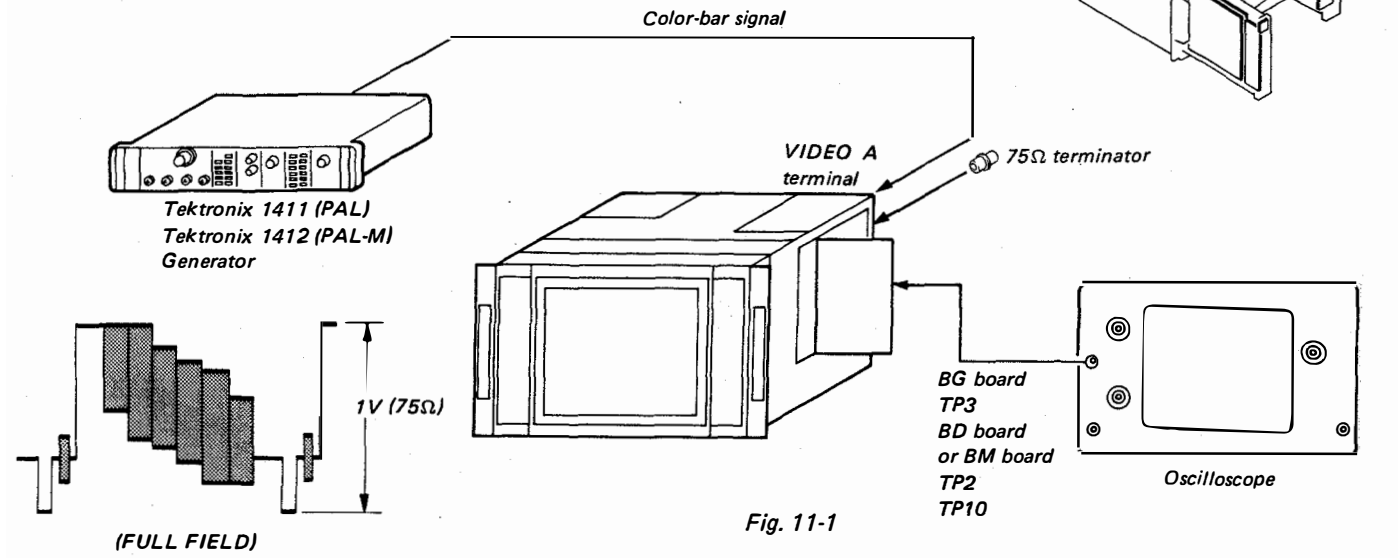

Fig. 10-1

11. BD BOARD (PAL) or BM BOARD (PAL-M)
COLOR DIFFERENCE PHASE ADJUSTMENT



1. Complete the connections as shown in Fig. 11-1.
2. Turn on the power of this monitor. Set the INPUT switch to the A position, the SYNC switch to the INT position, and the PAL switch to the S position.

B-Y System Adjustment

3. Connect the oscilloscope probe to TP3 on the BG board, and turn off the U (B-Y) signal of the signal generator.
4. Set the oscilloscope sensitivity to 20mV/DIV, and adjust RV8 on the BD or BM board so that the output waveform is flat. (See Fig. 11-2.)

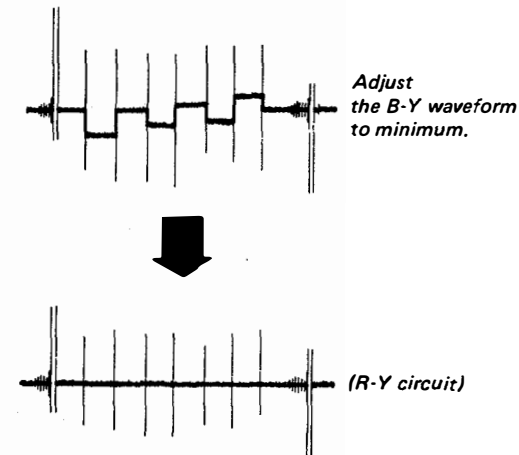
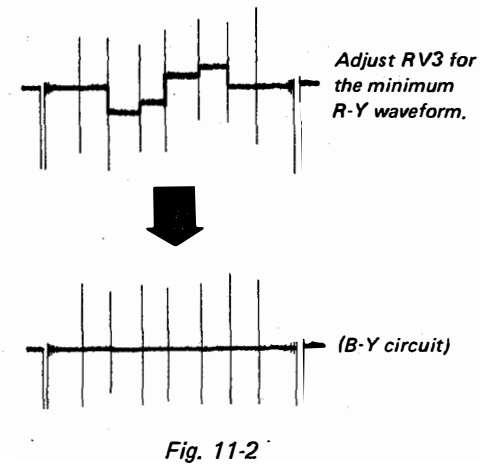

Quad Adjustment

5. Connect the oscilloscope probe to TP2 on the BD or BM board. Turn on the U signal of the signal generator, and turn off the V (R-Y) signal. Then adjust CV1 on the BD or BM board so that the output waveform is flat. (See Fig. 11-3.)
6. Repeat the steps 3 to 6.

PAL-D Phase Adjustment

7. Set the PAL switch to the D position and turn on the V signal of the signal generator, and turn off U signal.
8. Connect the oscilloscope probe to TP10 on the BD or BM board.
9. Adjust RV7 on the BD board so that the output waveform is flat. (See Fig. 11-2.)
10. Finally, perform the adjustments of 3 and 4 by directly mounting the BD or BM board to the set, without using the extension board.

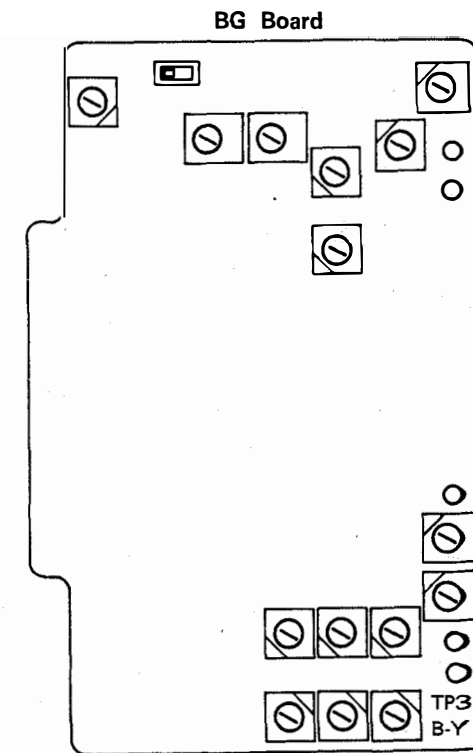
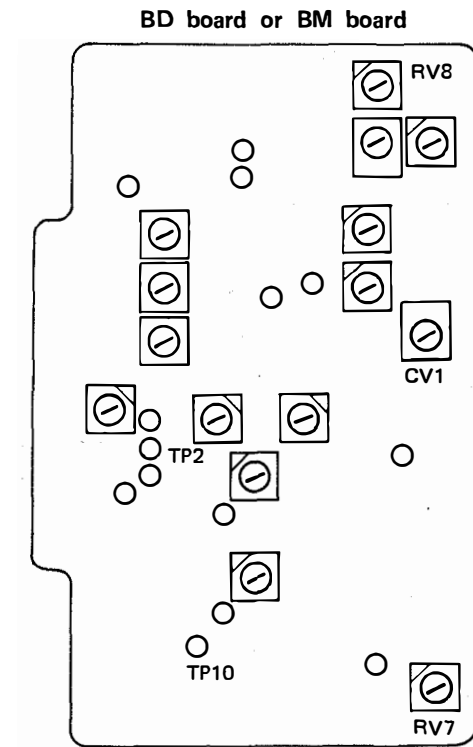

12. BD (PAL) OR BM (PAL-M) BOARD COLOR DIFFERENCE LEVEL ADJUSTMENT

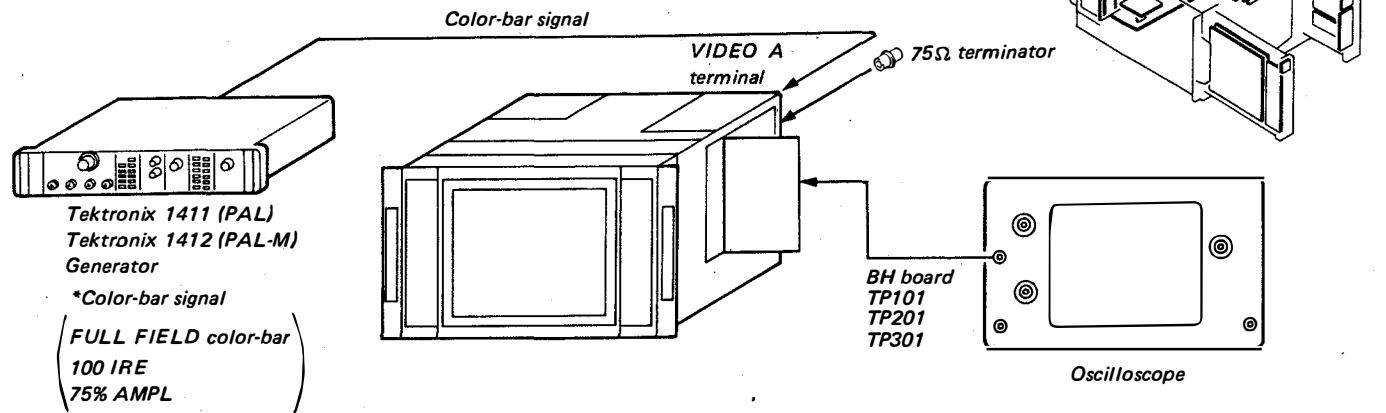

- * Set the PAL switch of the BVM-1410P or 1410PM to the S position.
- 1. Input color-bar signal to the VIDEO A terminal of the set.
- 2. Connect an oscilloscope to the TP101 of BH board.
- 3. Adjust RV3 of BD or BM board so that the level with * is flat as shown in Fig. 12-1.

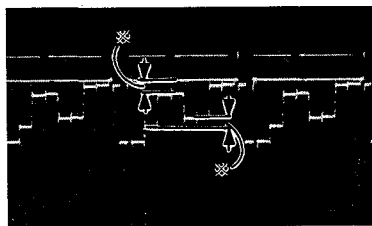

TP101 R OUT

Fig. 12-1

* Adjust the levels with * to be flat respectively using RV3 of BD or BM board.

- 4. Connect an oscilloscope to the TP301 of BH board.
- 5. Adjust RV4 of BD or BM board so that the output waveform as shown in Fig. 12-2.

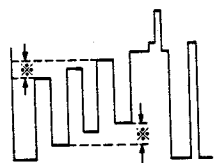

TP103 B OUT

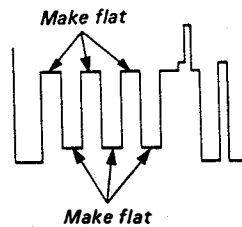
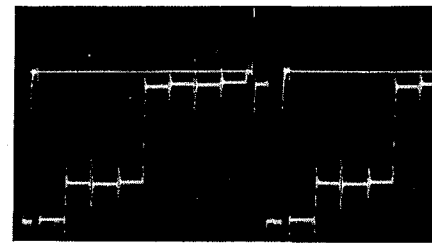

Fig. 12-2

- 6. Connect an oscilloscope to the TP201 of BH board.
- 7. Adjust RV4 and RV5 of BG board so that the INPUT waveform becomes flat as shown in Fig. 12-3.



TP201 G OUT

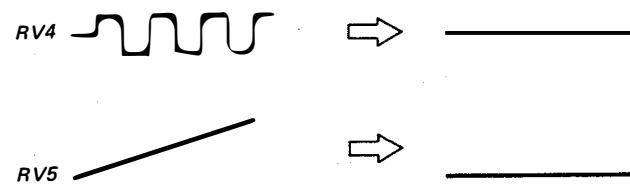
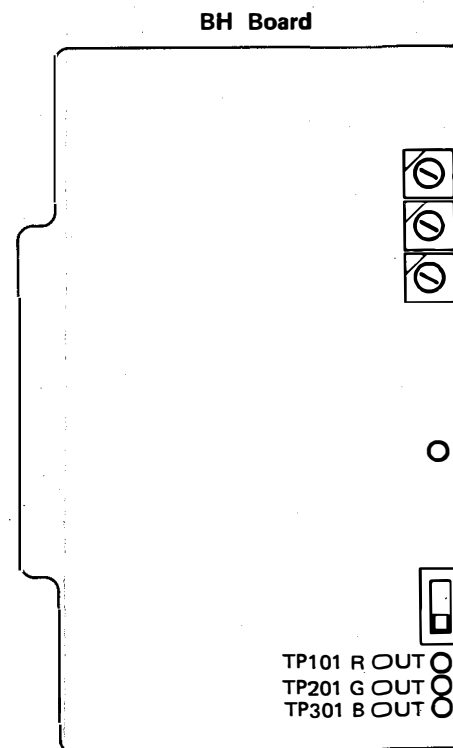
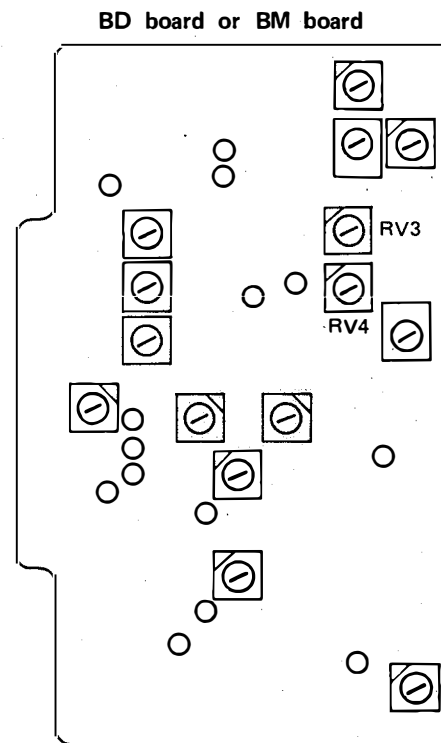
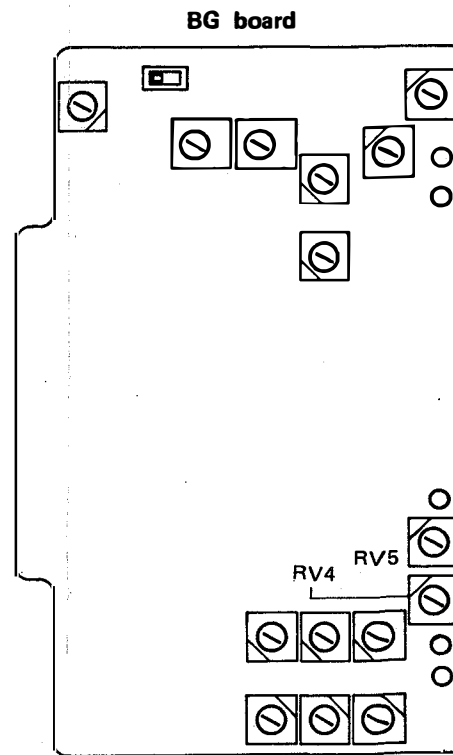
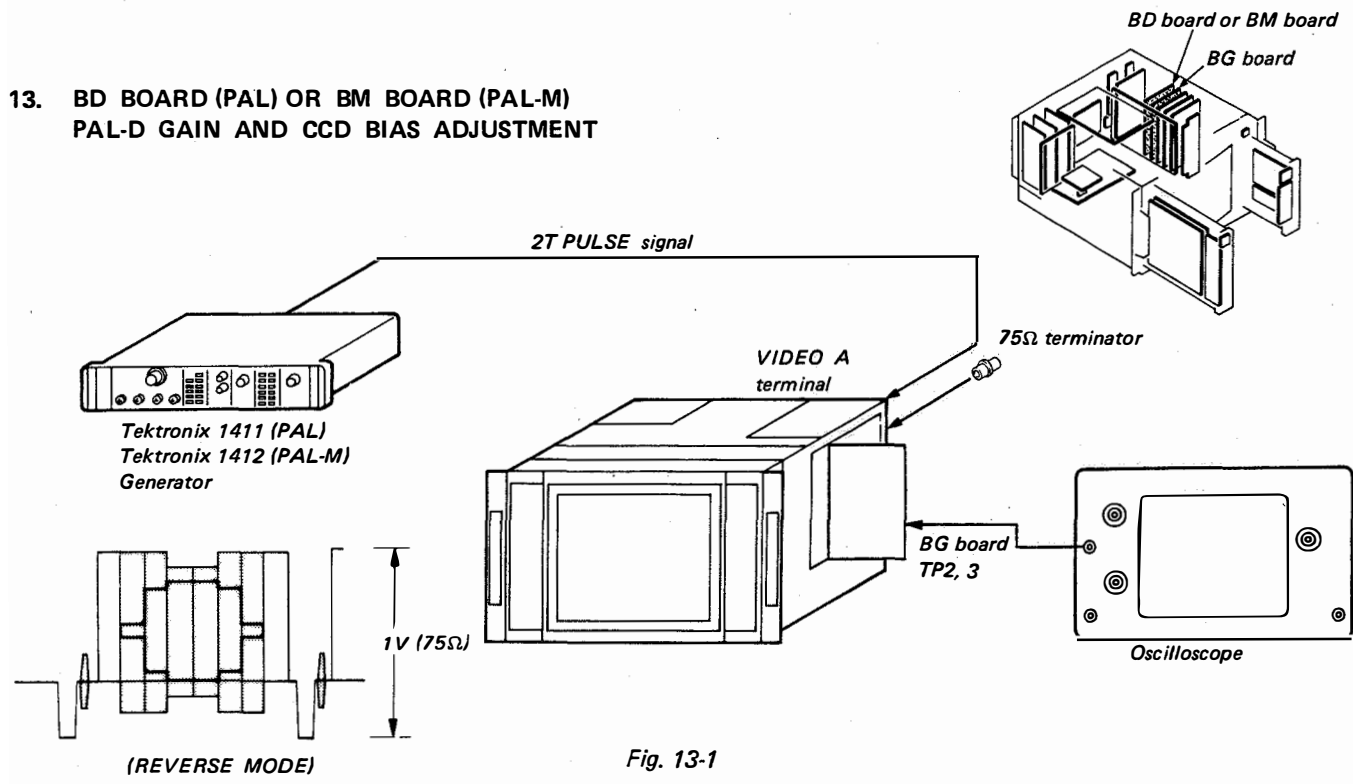

Fig. 12-3



13. BD BOARD (PAL) OR BM BOARD (PAL-M)
PAL-D GAIN AND CCD BIAS ADJUSTMENT



* Set the PAL switch of BVM-1410P or 1410PM to the D position.

1. Complete the connections as shown in Fig. 13-1. Turn on the power of this monitor. Set the INPUT switch to the A position, and the SYNC switch to the INT position.
2. Connect the oscilloscope probe to TP2 on the BG board.
3. Turn RV5 and RV6 on the BD or BM board fully clockwise.
4. By observing the waveform shown in Fig. 13-2, adjust RV9 on the BD or BM board so that it becomes A = B.
5. Adjust RV5 on the BD or BM board so that the waveform shown in Fig. 13-2 becomes flat.
6. Connect the probe of the oscilloscope to TP3 on the BG board and observe the section shown in Fig. 13-3.
7. Adjust RV10 on the BD or BM board so that the waveform of the oscilloscope becomes A = B.
8. Adjust RV6 on the BD or BM board so that the waveform shown in Fig. 13-3 becomes flat.

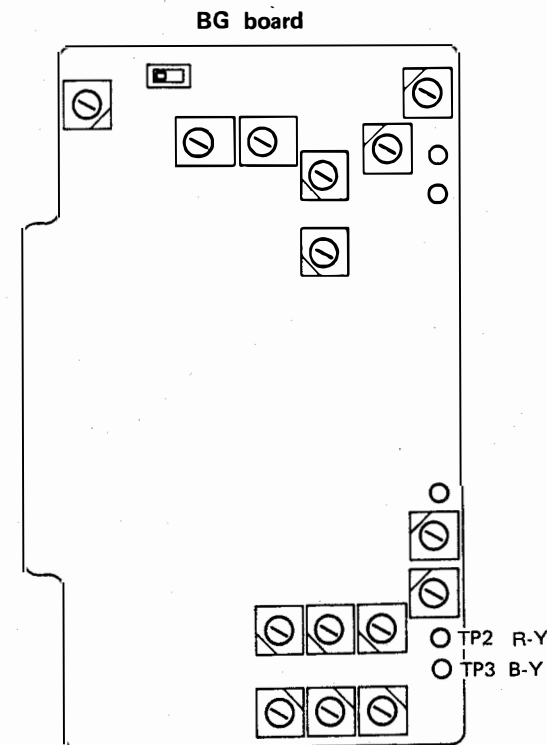
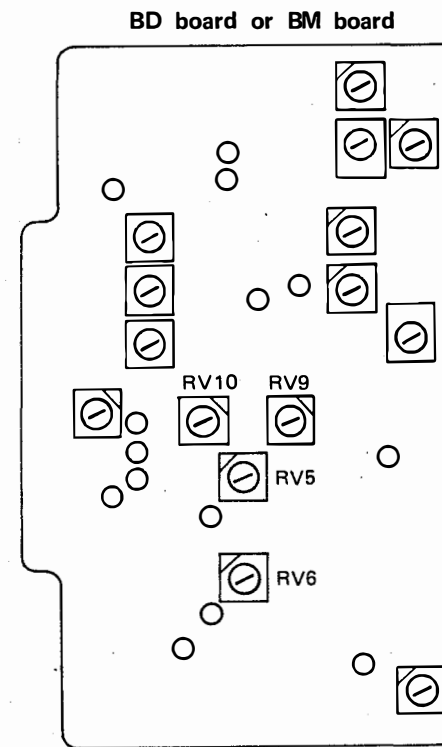
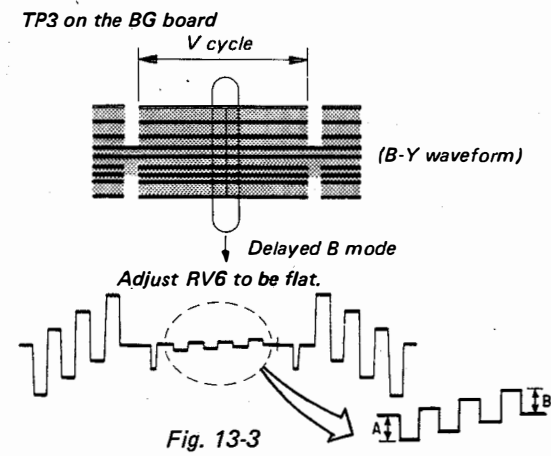
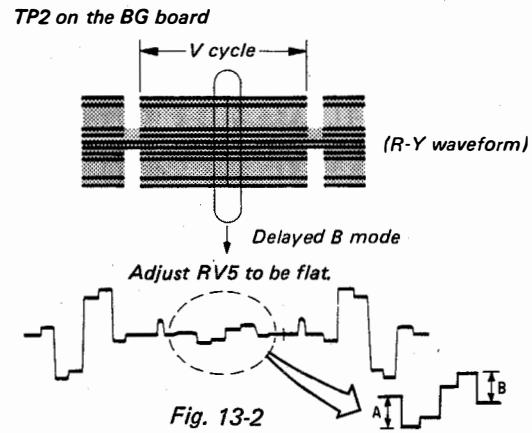

**14. BD BOARD (PAL) OR BM BOARD (PAL-M)
Y TRAP ADJUSTMENT**

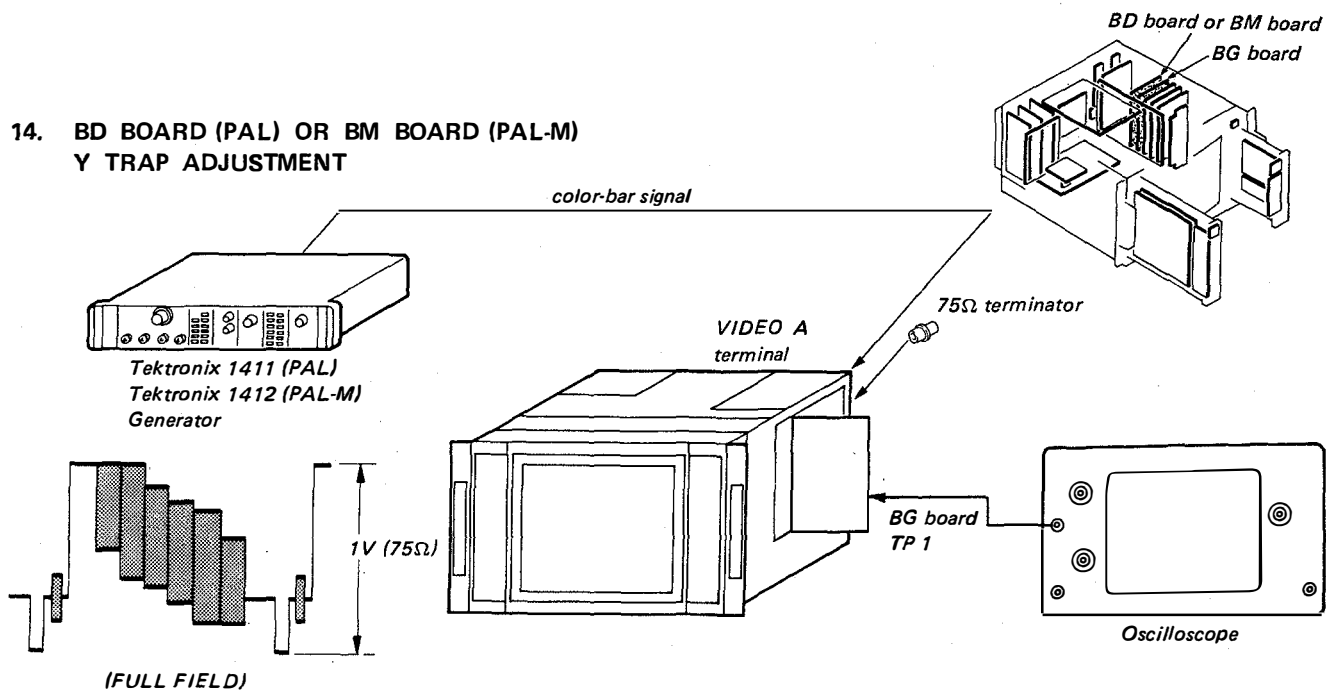

1. Input color-bar signal to VIDEO A terminal of the set.
2. Connect an oscilloscope to the TP1 of BG board.
3. Adjust L1 of BD or BM board so that 4.43 MHz (PAL) or 3.58 MHz (PAL-M) subcarrier is minimum as shown in Fig. 14-1.

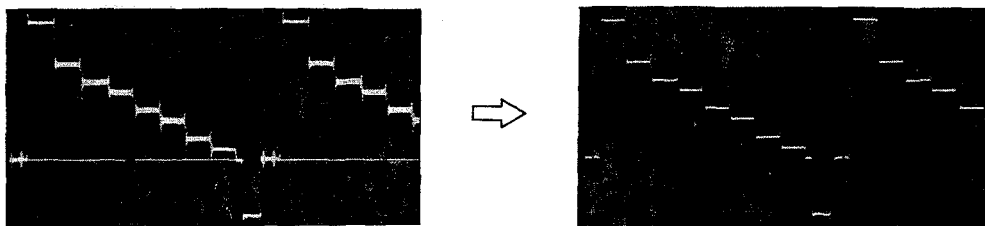
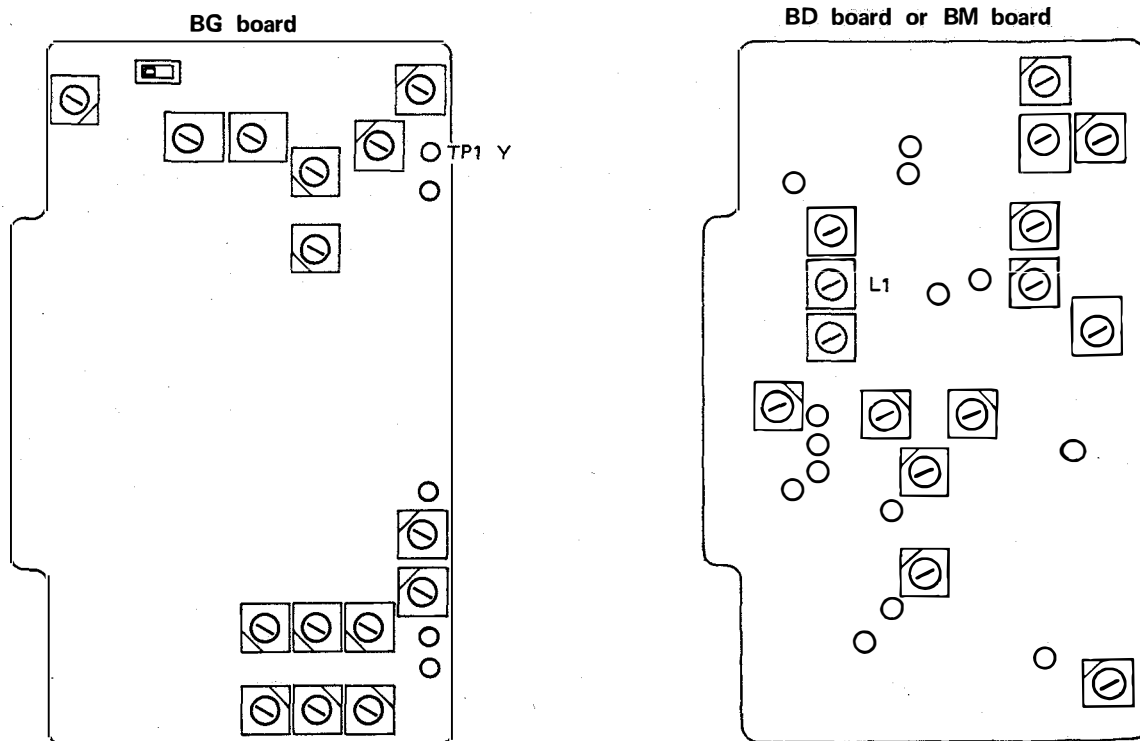
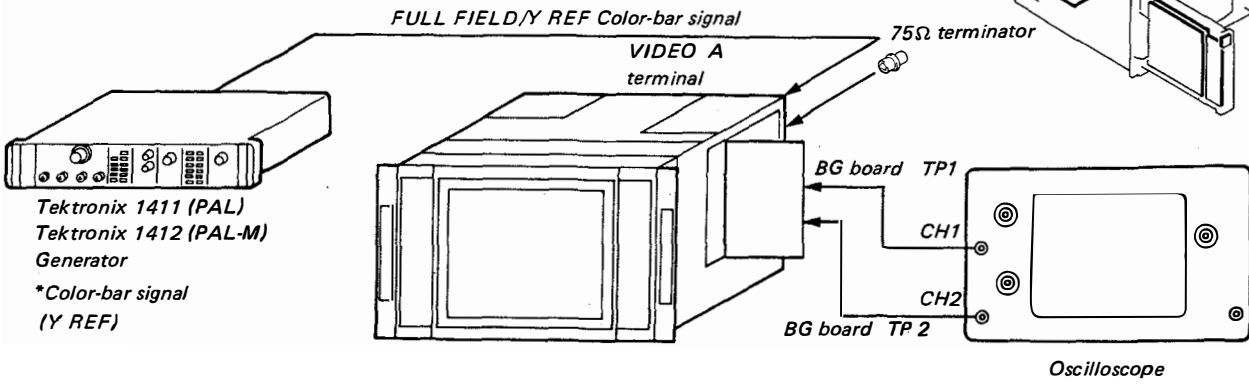
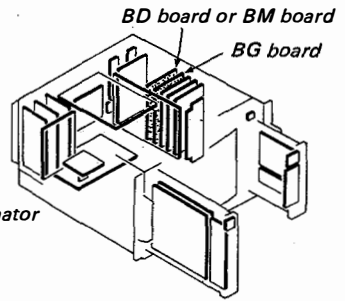

Fig. 14-1



15. BD BOARD (PAL) OR BD BOARD (PAL-M) Y-C DELAY TIME ADJUSTMENT



- * Set the PAL switch of the BVM-1410P or 1410PM to the S position.
- 1. Input color-bar signal (FULL FIELD/Y REF) to the VIDEO A terminal of the set.
- 2. Connect an oscilloscope (CH-1 probe) to the TP1 of BG board and connect an oscilloscope (CH-2 probe) to the TP2 of BG board (VERT mode of the oscilloscope is CHOP).
- 3. Adjust RV1 of BD or BM board so that the output waveform as shown in Fig. 15-1.

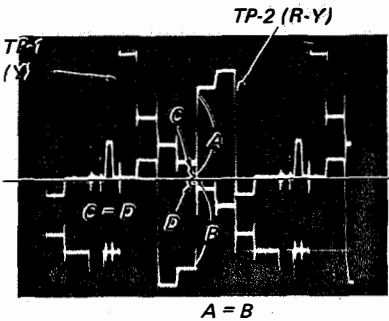

(A=B)
(C=D)

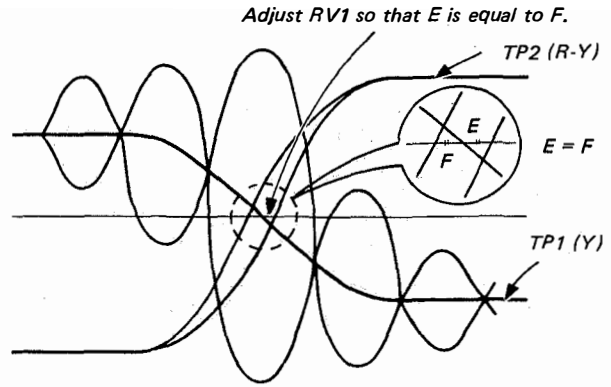
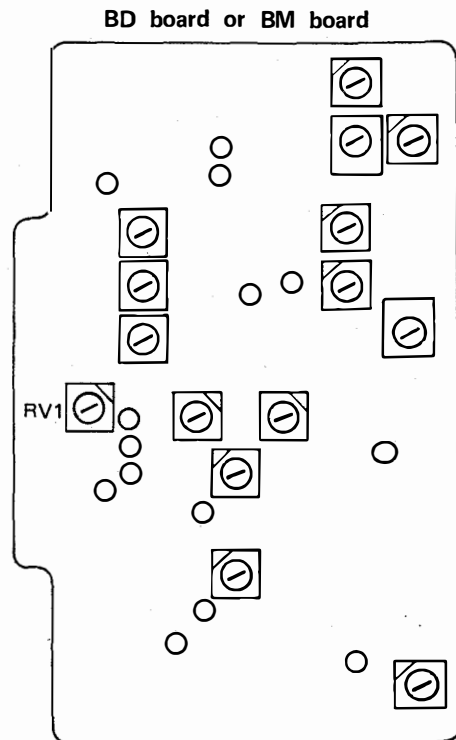
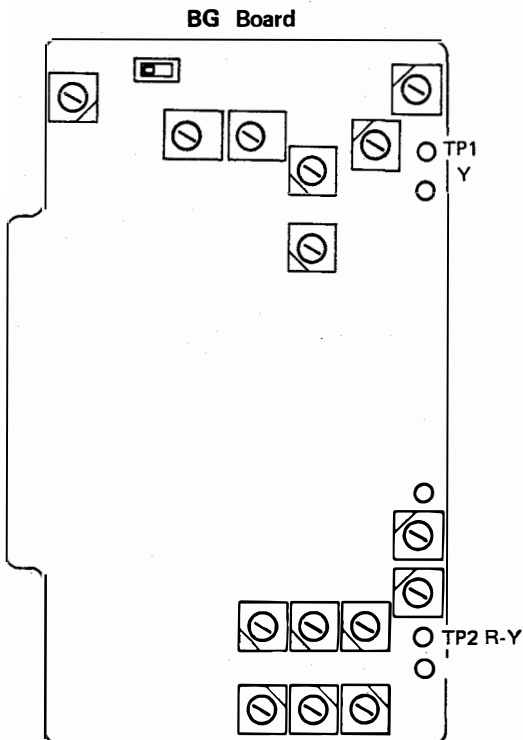
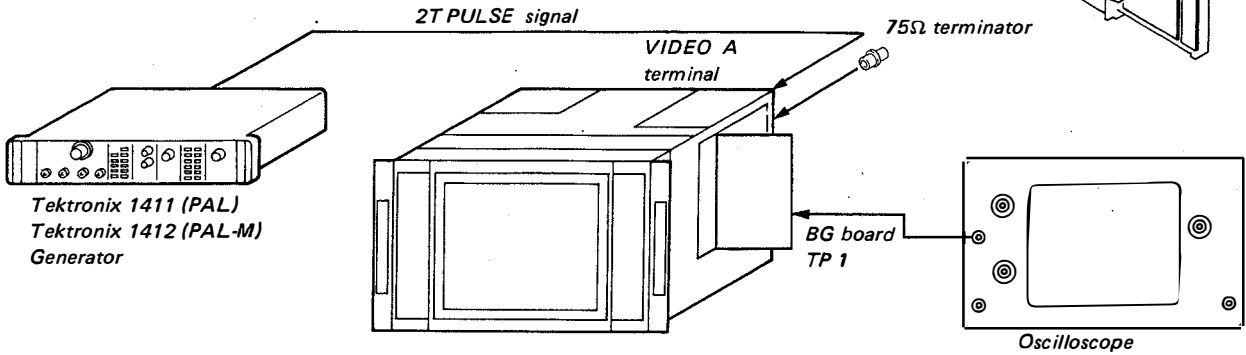
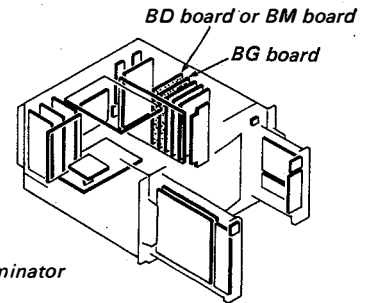

Fig. 15-1



4. ADJUSTMENTS

16. BD BOARD (PAL) OR BM BOARD (PAL-M) 2T PULSE CORRECTION ADJUSTMENT



1. Input 2T pulse signal to VIDEO A terminal of the set.
2. Connect an oscilloscope to the TP1 of BG board.
3. Adjust L2 of BD or BM board so that A is equal to B as shown in Fig. 16-1.
4. Change the input signal from 2T pulse to T pulse, and make sure the waveform balance is not lost extremely as shown in Fig. 16-1.

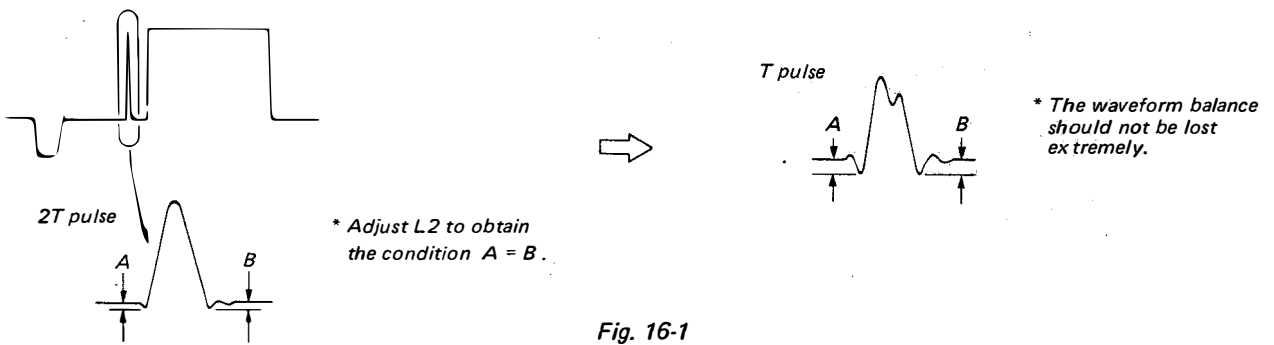
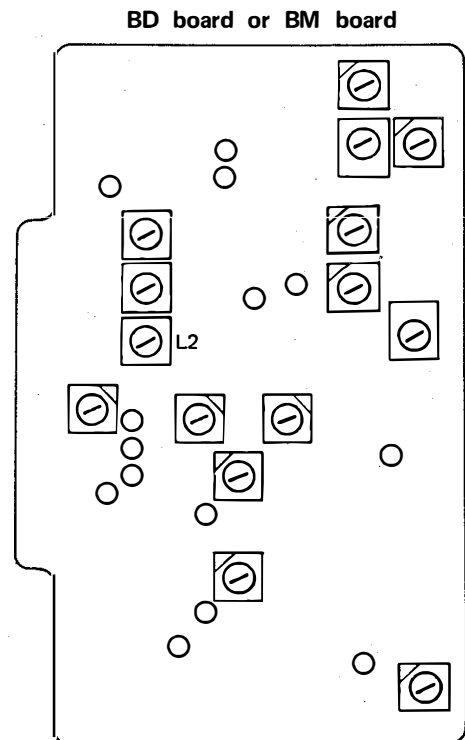
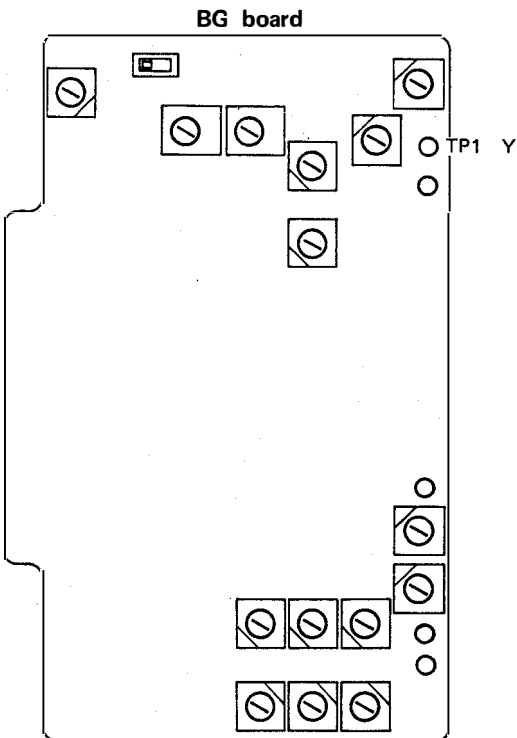
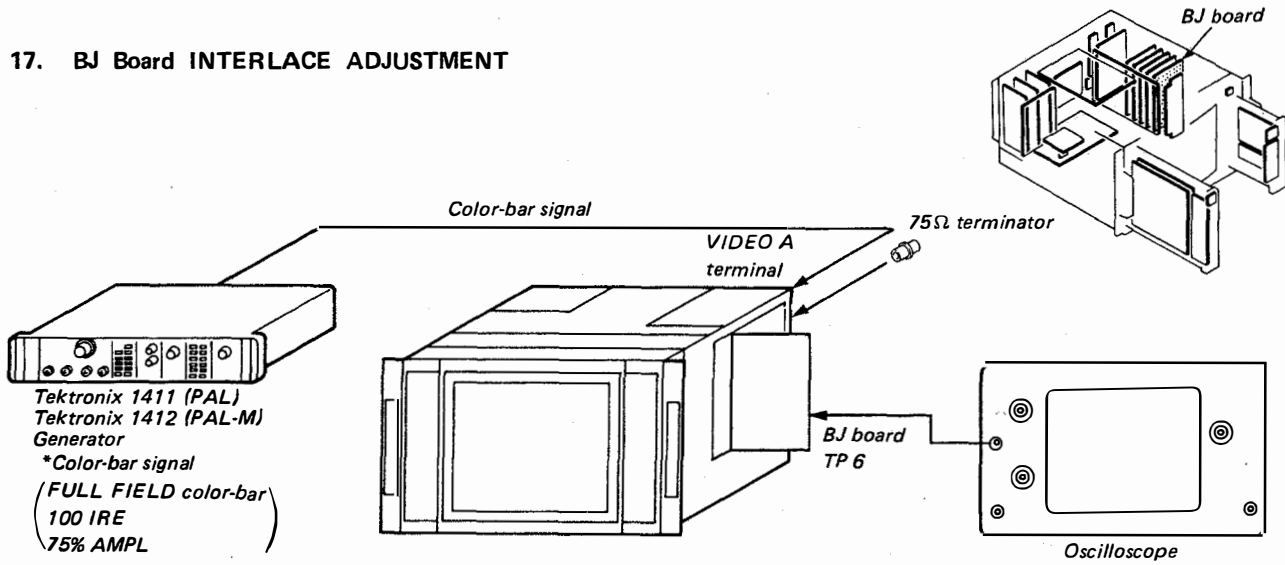

Fig. 16-1



17. BJ Board INTERLACE ADJUSTMENT



1. Input color-bar signal to the VIDEO A terminal of the set.
2. Connect an oscilloscope to the TP6 on the BJ board.
3. Adjust RV6 to obtain the waveform on the oscilloscope as shown in Fig. 17-1.

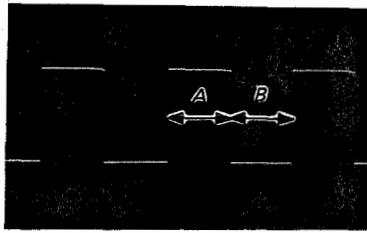
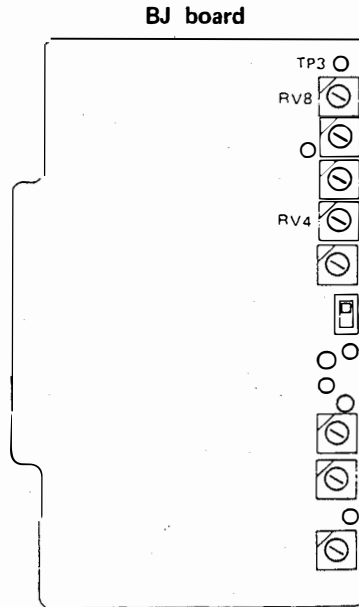
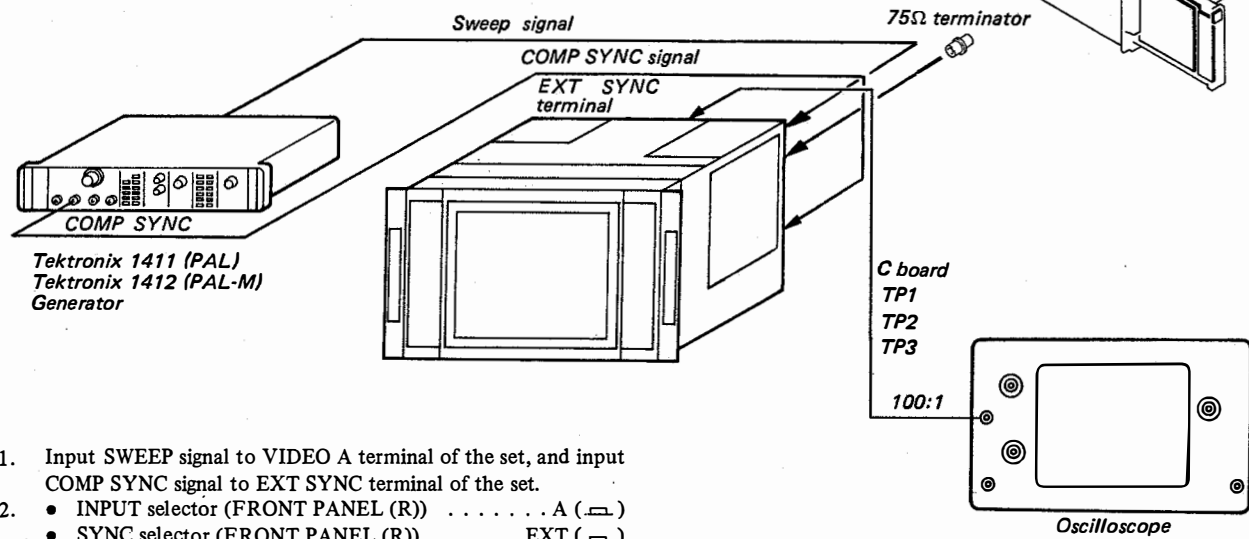
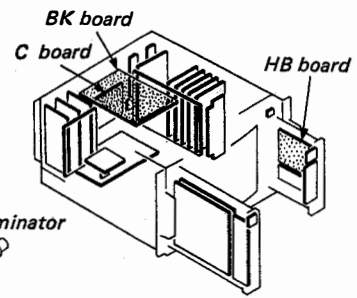

Fig. 17-1



18. BK Board FREQUENCY CHARACTERISTIC ADJUSTMENT



1. Input SWEEP signal to VIDEO A terminal of the set, and input COMP SYNC signal to EXT SYNC terminal of the set.
2.
 - INPUT selector (FRONT PANEL (R)) A (A)
 - SYNC selector (FRONT PANEL (R)) EXT (EXT)
 - MODE selector (FRONT PANEL (R)) MONO (MONO)
 - FILTER SW. (HB board S8) OFF
3. Connect an oscilloscope to the TP1 on the C board.
*Probe: 100:1
4. Adjust CV101 and CV102 on the BK board so that output waveform becomes flat in a range of 0 to 8MHz as shown in Fig. 18-1.

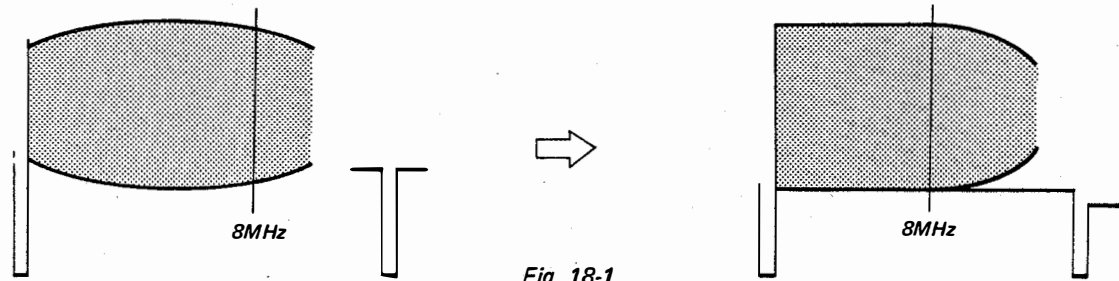
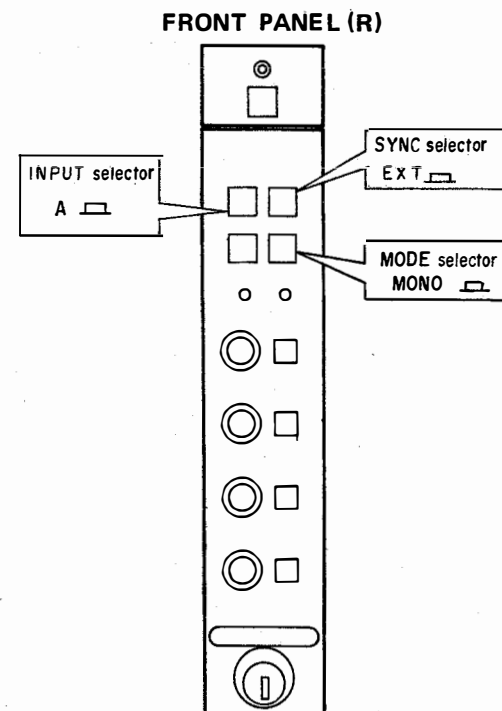
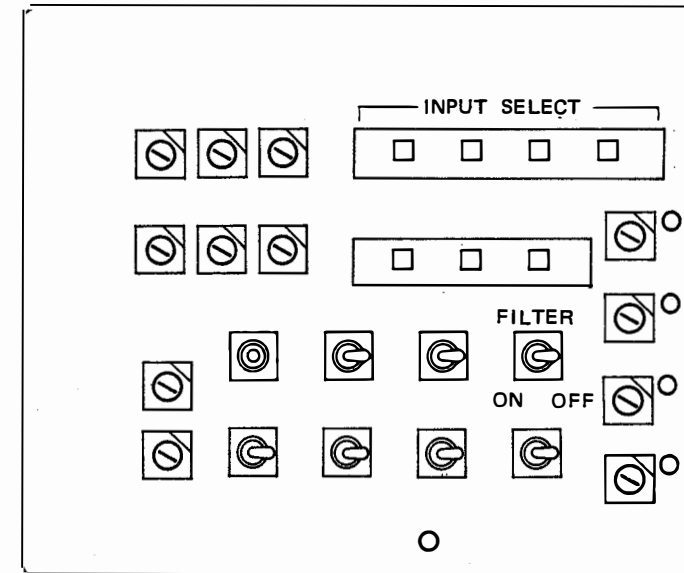

Fig. 18-1

5. Connect an oscilloscope to the TP2 on the C board.
6. Adjust CV201 and CV202 on the BK board so that output waveform becomes flat in a range of 0 to 8MHz as shown in Fig. 18-1.
7. Connect an oscilloscope to the TP3 on the C board.
8. Adjust CV301 and CV302 on the BK board so that output waveform becomes flat in a range of 0 to 8MHz as shown in Fig. 18-1.



HB board



C board

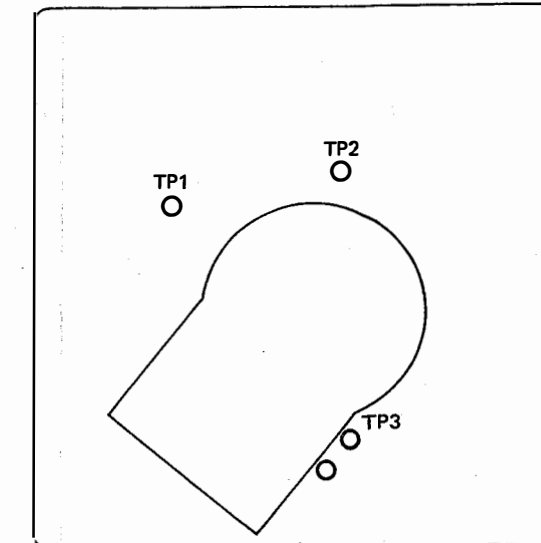

BK board

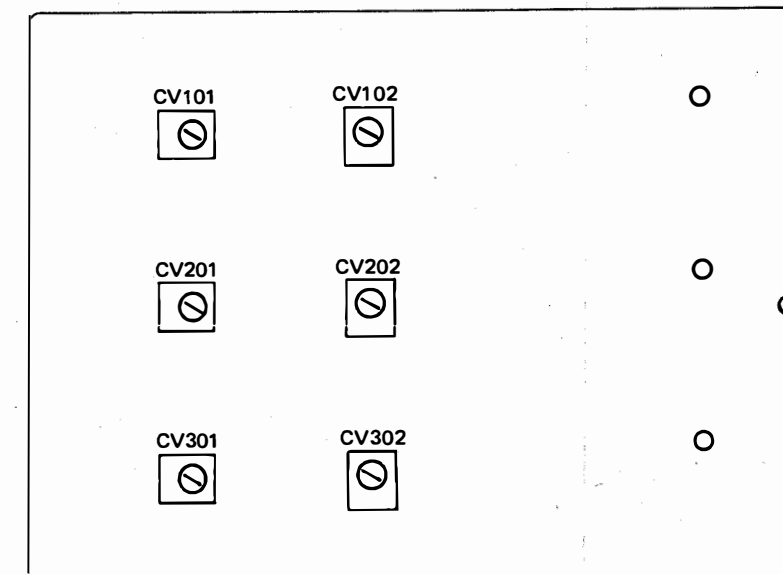

19. VECTOR OUTPUT ADJUSTMENT

PAL

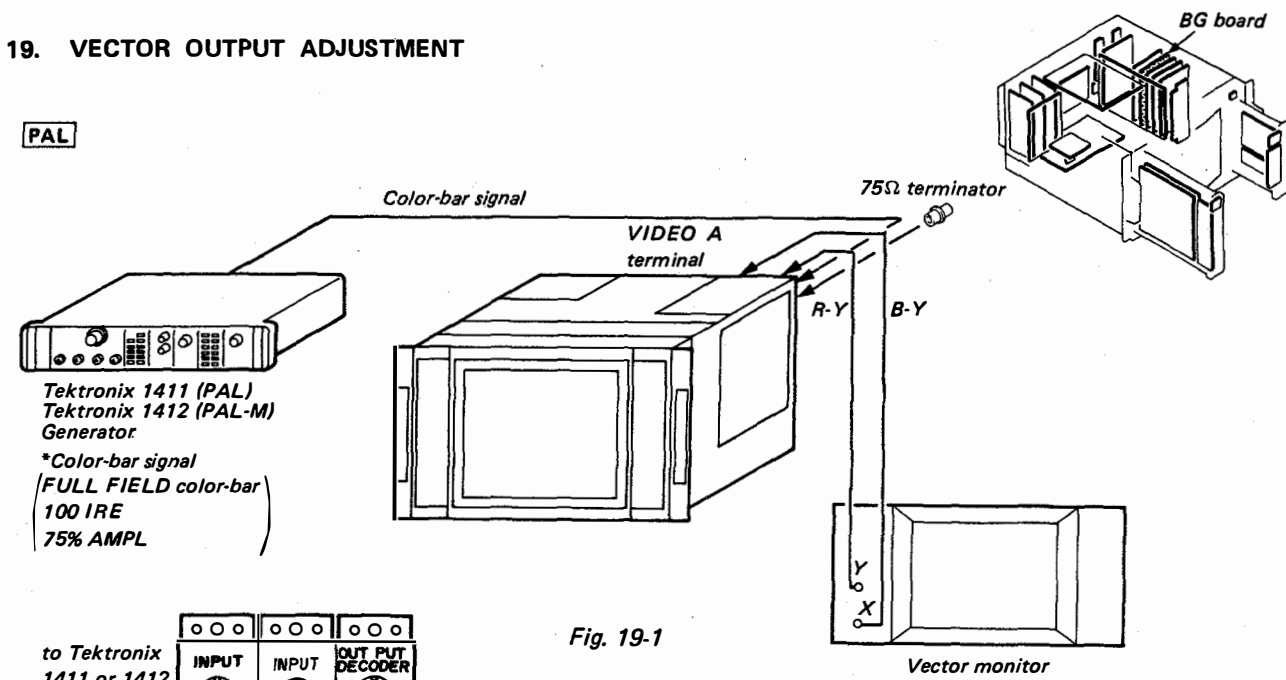

Fig. 19-1

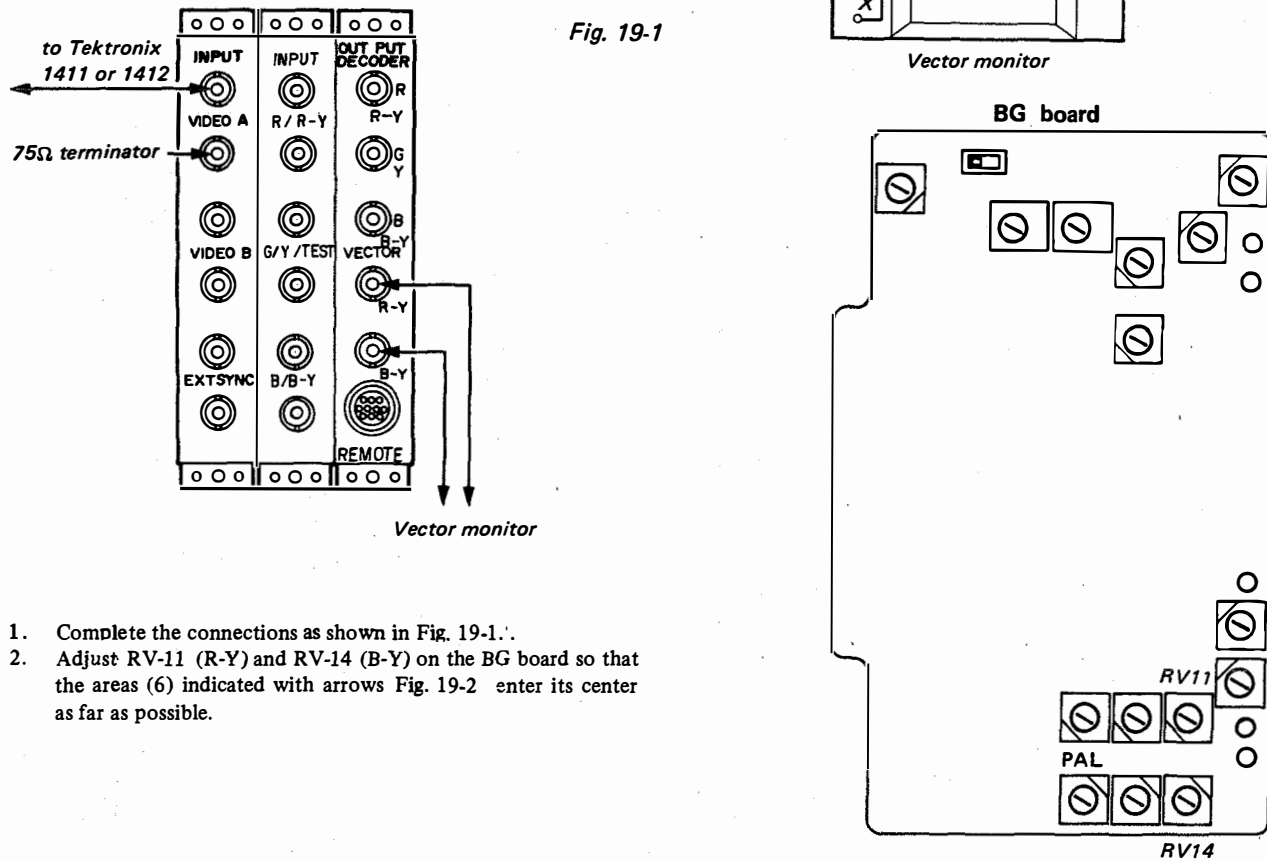
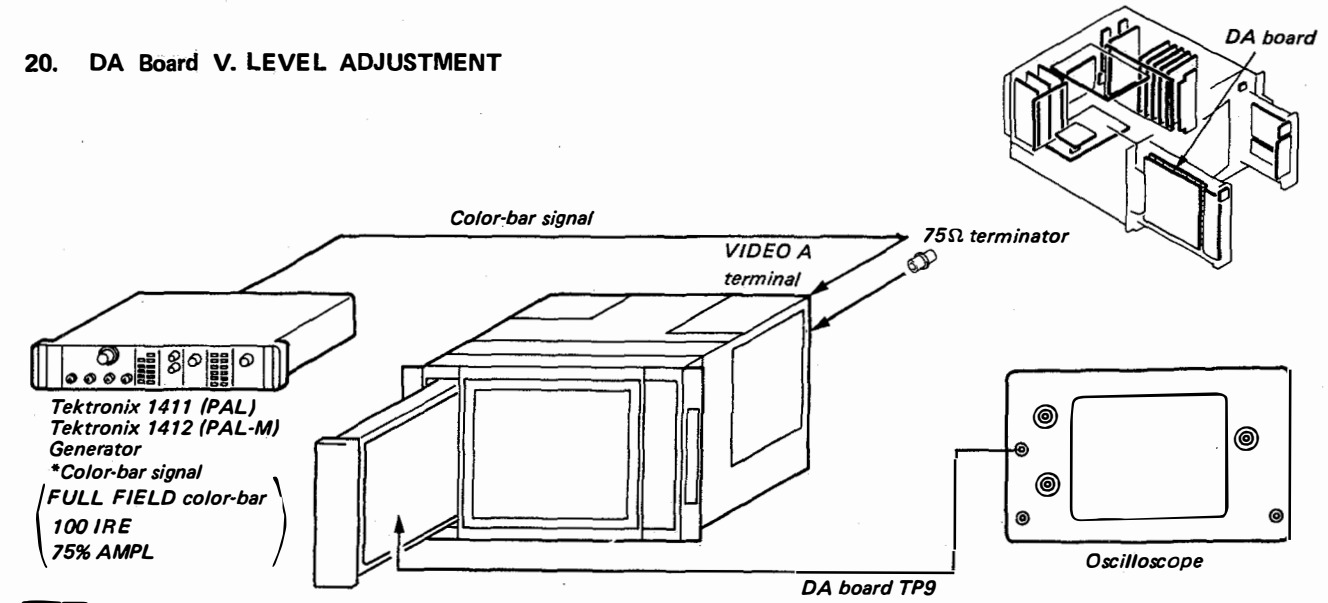

Fig. 19-2

20. DA Board V. LEVEL ADJUSTMENT

PAL



1. Input color-bar signal to the VIDEO A terminal of the set.
2. Connect an oscilloscope to the TP9 on the DA board.
3. Adjust RV18 on the DA board so that output waveform is 12.0Vp-p as shown in Fig. 20-1.

The following adjustment is required when a PAL-M or NTSC system signal is received.

PAL-M **NTSC**

4. Input color-bar signal (TEK-1412 or TEK-1410) to the VIDEO A terminal of the set.
5. Connect an oscilloscope to the TP9 on the DA board.
6. Adjust RV17 on the DA board so that output waveform is 12.0Vp-p.



Fig. 20-1

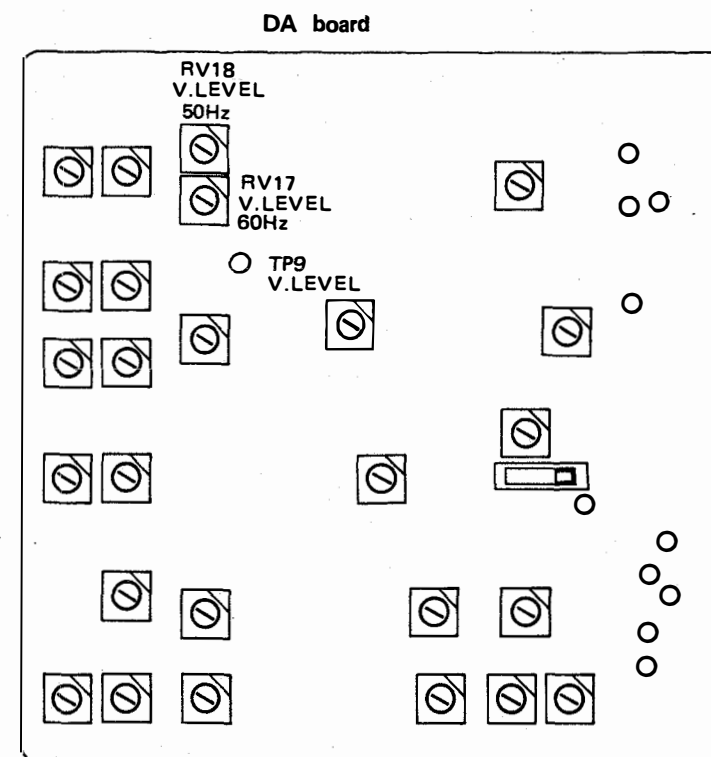

21. DA Board LINEARITY ADJUSTMENT

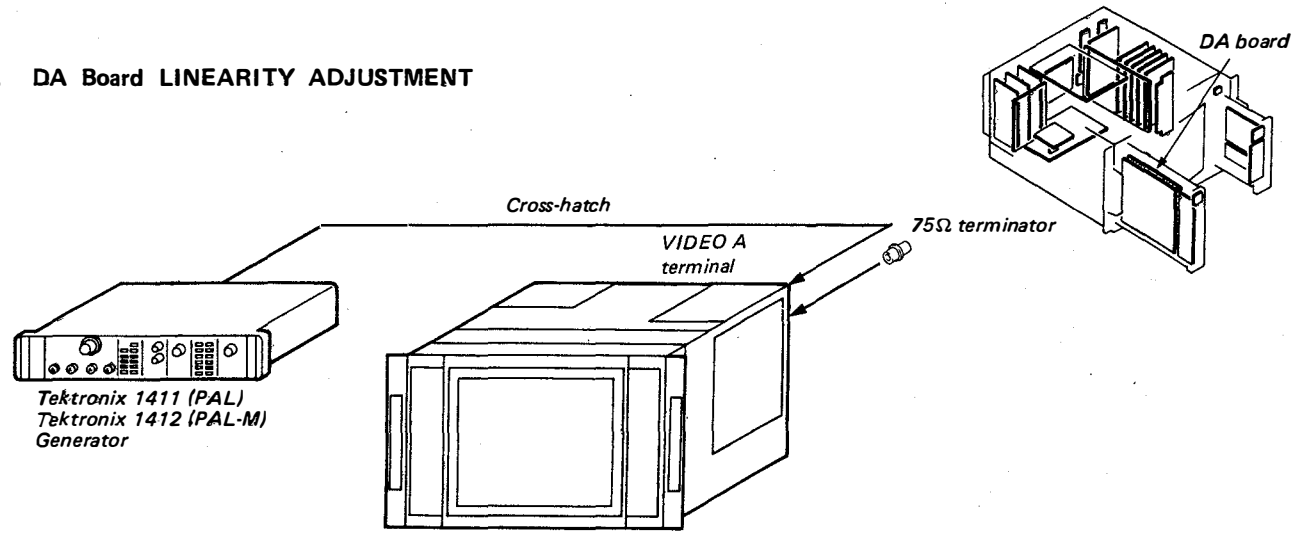

TOP AND BOTTOM PIN ADJUSTMENT

1. Receive cross-hatch signal and with H-LINE only.
2. Adjust T&B pin distortion H PHASE by turning DA board RV27 (TRAPEZOID) as shown in Fig.
3. Adjust T&B pin distortion gain by turning DA board RV13 as shown in Fig. 21-1.
4. Adjust T&B pin distortion vertical balance by turning DA board RV10 as shown in Fig. 21-1.
5. Adjust PARALLELOGRAM distortion by turning DA board RV28 (PARALLEL) as shown in Fig. 20-1.
6. Mark tracking by repeating 2 through 5.
7. UNDER SCAN switch UNDER (☐).
8. Adjust T&B distortion gain by turning DA board RV14.

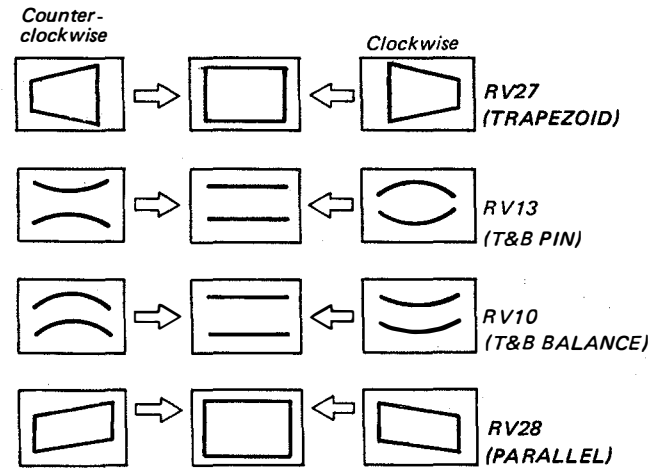
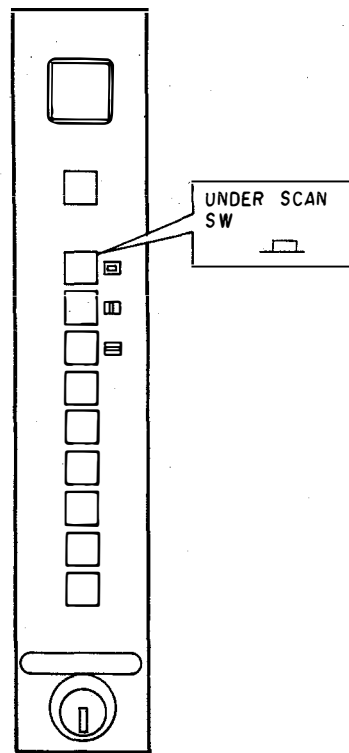
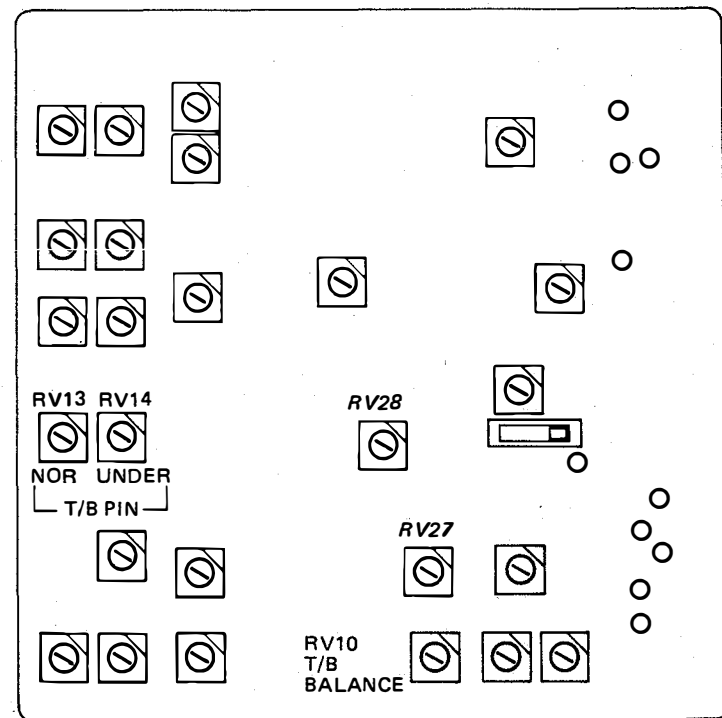

Fig. 21-1

FRONT PANEL (L)



DA board



V. LINEARITY ADJUSTMENT

1. Receive cross-hatch signal and with H-LINE only.
2. Adjust V. CENTER by turning DA board RV21.
3. Adjust V. LIN BALANCE by turning DA board RV20 as shown in Fig. 21-2.
4. Adjust V. LIN GAIN by turning DA board RV22 as shown in Fig. 20-3.
5. Adjust V. HEIGHT by turning DA board RV23.
6. Mark tracking by repeating steps 2. through 5.

RV20 V LIN BALANCE

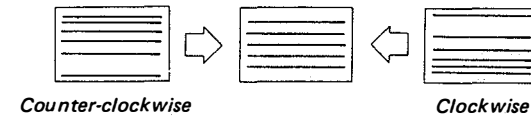

Fig. 21-2

RV22 V LIN GAIN

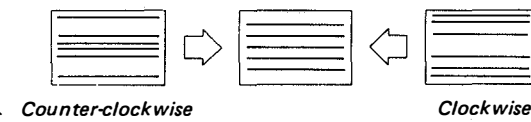

Fig. 21-3

SIDE PIN ADJUSTMENT

1. Receive cross-hatch signal and with V. LINE only.
2. Adjust SIDE PIN by turning DA board RV15 as shown in Fig. 21-4.
3. Adjust SIDE PIN TILT by turning DA board RV19 as shown in Fig. 21-5.
4. Adjust H. CENTER LINE by turning DA board RV25 as shown in Fig. 21-6.

RV15 (SIDE PIN)

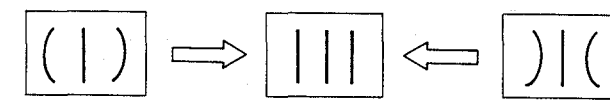

Fig. 21-4

RV19 (SIDE PIN TILT)

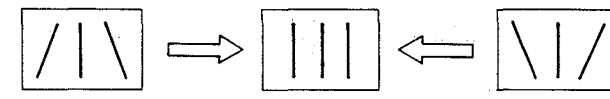

Fig. 21-5

RV25 (H. CENTER LINE)

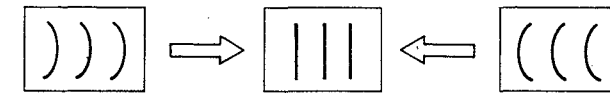
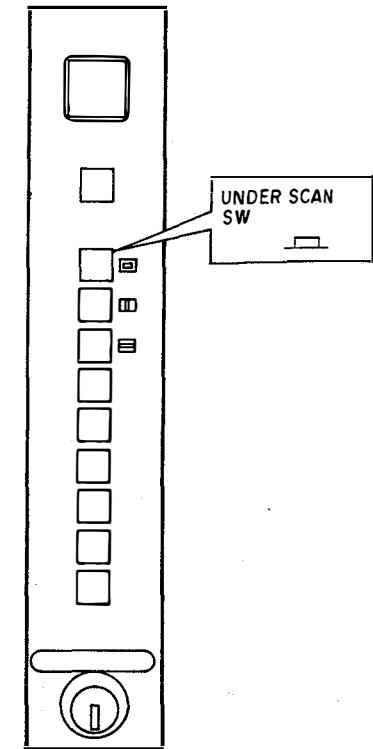

Fig. 21-6

5. UNDER SCAN switch (Front panel (L)) UNDER (☐)
6. Adjust SIDE PIN by turning DA board RV16.

FRONT PANEL (L)



DA board

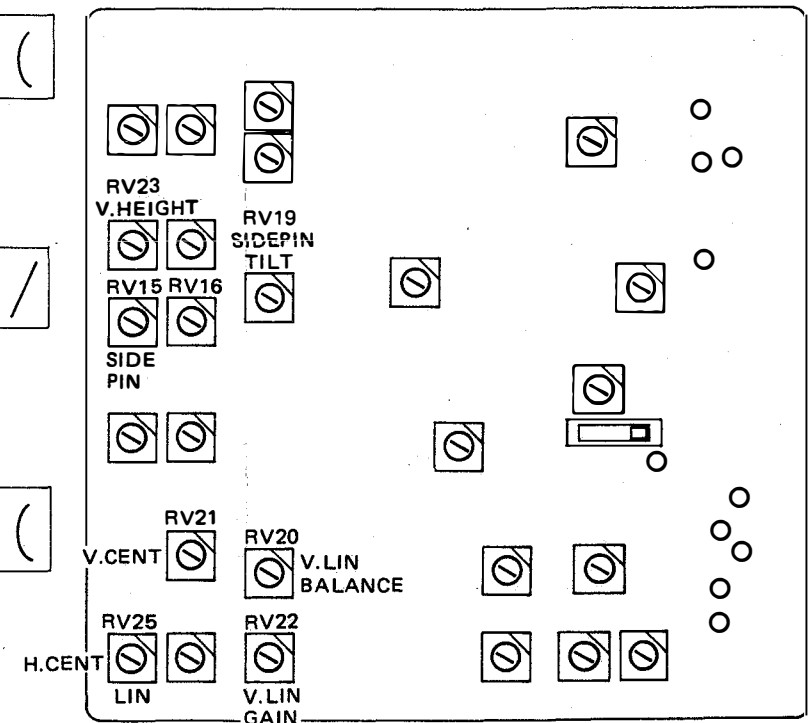

H. LINEARITY ADJUSTMENT

1. Receive cross-hatch signal and with V-LINE only.
2. Adjust H. LINEARITY by turning DA board RV6 (H LIN GAIN) as shown in Fig. 21-7.

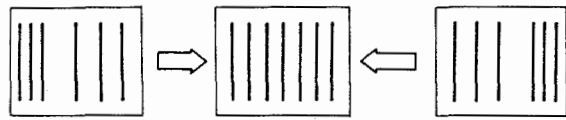

Fig. 21-7

22. H. FREQ ADJUSTMENT

1. Receive cross-hatch signal, and SYNC selector to EXT (EXT).
2. Adjust until the picture stops drifting or moves slowly by turning DA board RV5 as shown in Fig. 22-1.

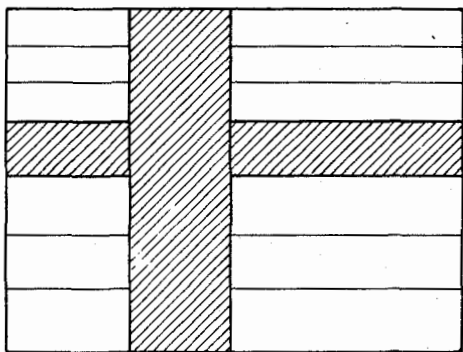

Fig. 22-1

H. BLK Adjustment

5. Connect an oscilloscope to the TP1 on the DA board.
6. Adjust RV1 on the DA board so that the H. BLK pulse width is 9.8μs. Fig. 23-2.

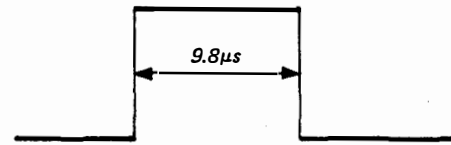

Fig. 23-2

H. BLK PHASE Adjustment

7. Adjust RV7 on the DA board so that the blanking width at the right and the left sides are equal to as shown in Fig. 23-3.

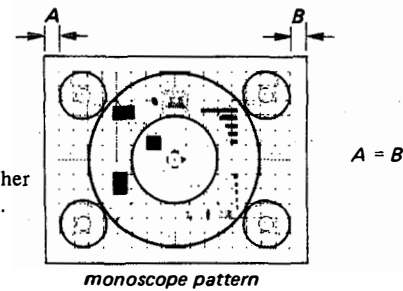

Fig. 23-3

H. PHASE Adjustment

8. Adjust RV26 on the DA board so that the outside raster portions of the picture become equal at the right and the left sides as shown in Fig. 23-4.

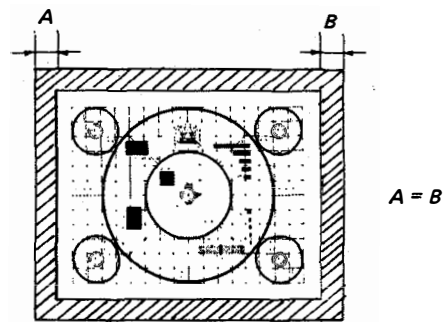

Fig. 23-4

23. DA Board H. CENTER, H. BLK PHASE ADJUSTMENT

1. Receive monoscope signal, and UNDER SCAN switch to UNDER (UNDER).
2. Picture tube
 - V. DELAY switch IN (IN)
3. Adjust RV1 and RV7 on the DA board so that the raster can all be seen by RV1 and RV7 as shown in Fig. 23-1.

H. CENTER

4. Adjust RV26 on the DA board so that the out side raster portions of the picture become equal to at the right and the left sides as shown in Fig. 23-1.

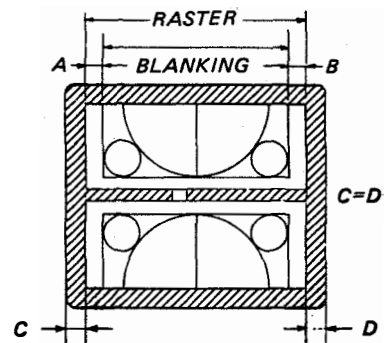
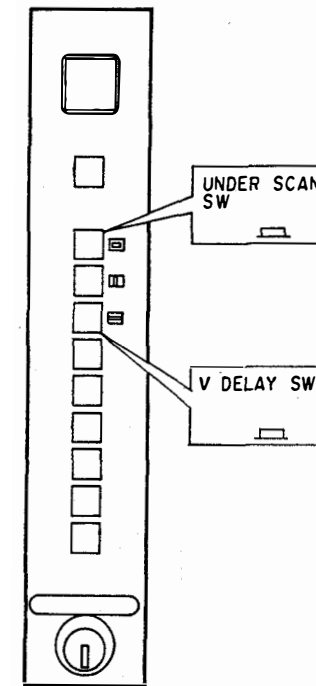
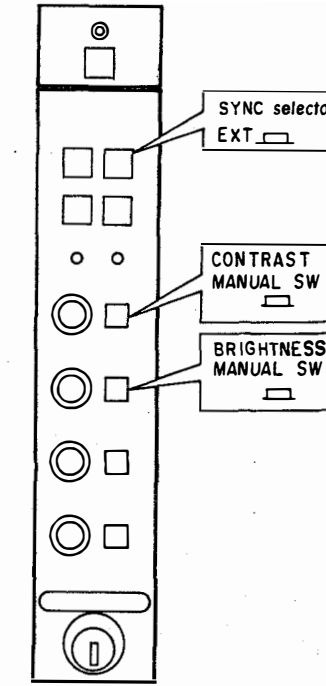

Fig. 23-1

FRONT PANEL (L)



FRONT PANEL (R)



DA board

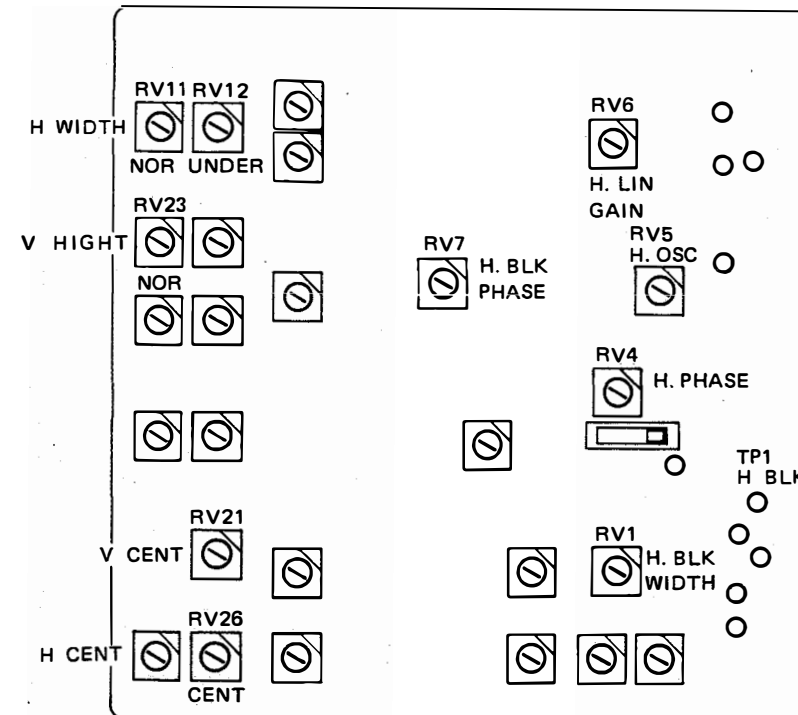

24. DA Board H DELAY POSITION ADJUSTMENT

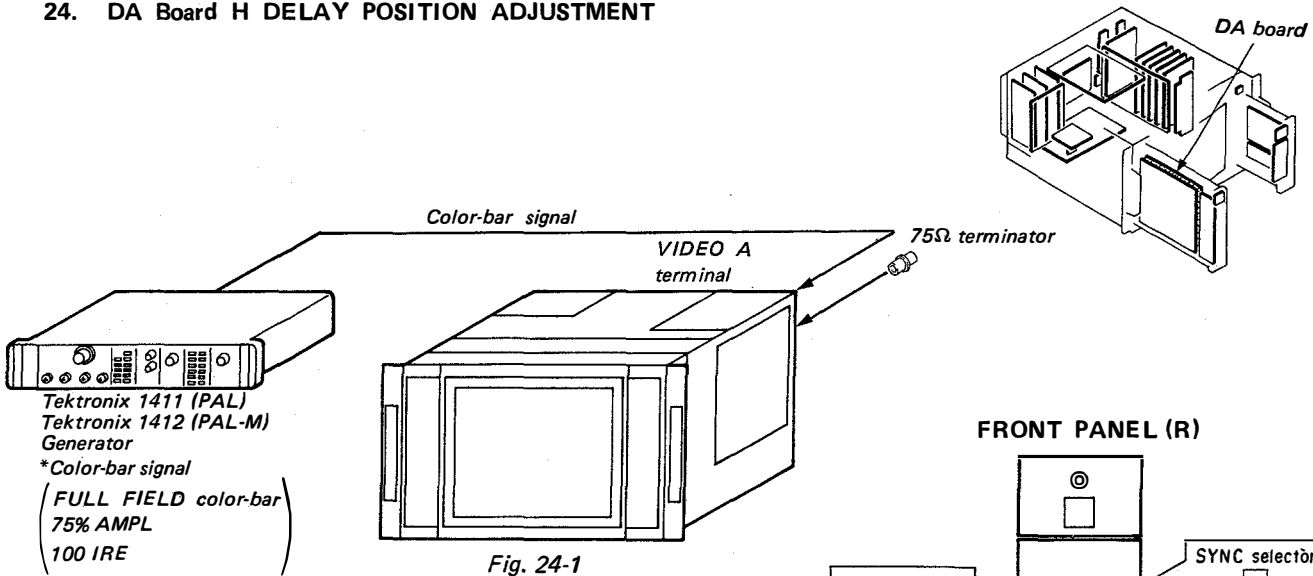
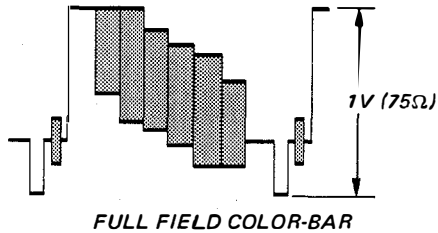

Fig. 24-1



1. Connect as shown in Fig. 24-1.
2. Turn the INPUT selector to "A" () SYNC selector to "INT" () and, H DELAY & V DELAY SW to "IN" () (pulse close position).
3. Adjust the H-DELAY position as shown in Fig. 24-2 by turning DA Board RV2.

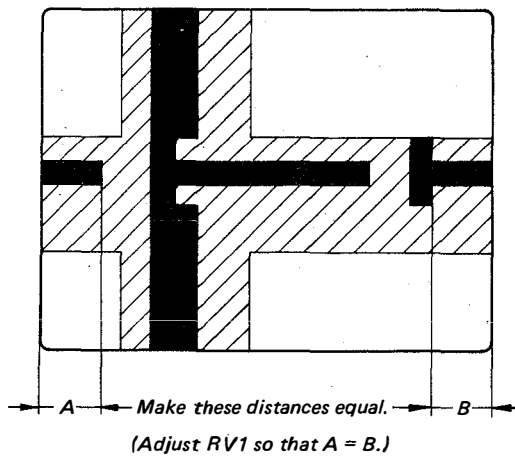
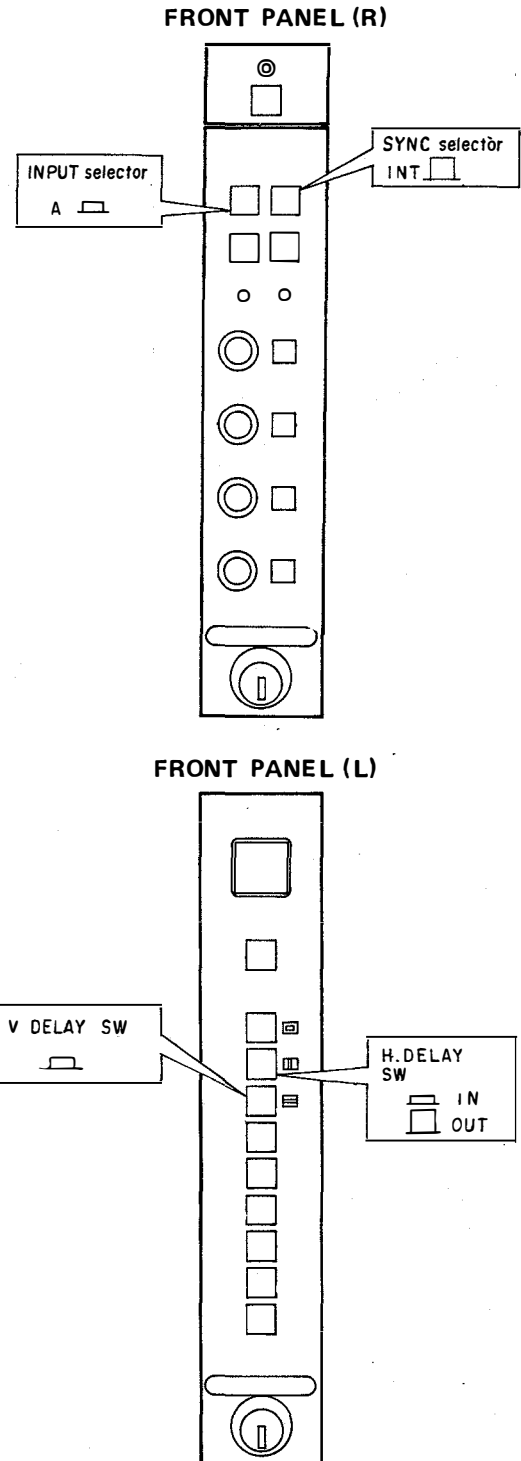

Fig. 24-2

H. DELAY PULSE WIDTH ADJUSTMENT

1. Connect an oscilloscope to the TP2 on the DA board.
2. Adjust RV3 on the DA board so that PULSE width is equal when switching H-DELAY switch IN and OUT.



DA board

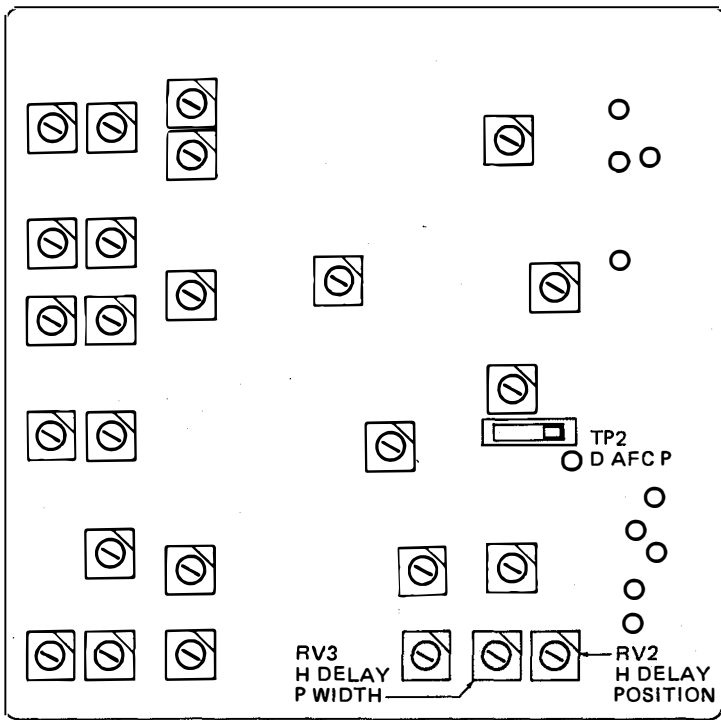

||||||| 4. ADJUSTMENTS

BLOCK DIAGRAM BLOCK DIAGRAM

SECTION 5 DIAGRAMS

5-1. BLOCK DIAGRAM
SIGNAL PROCESSING BLOCK DIAGRAM

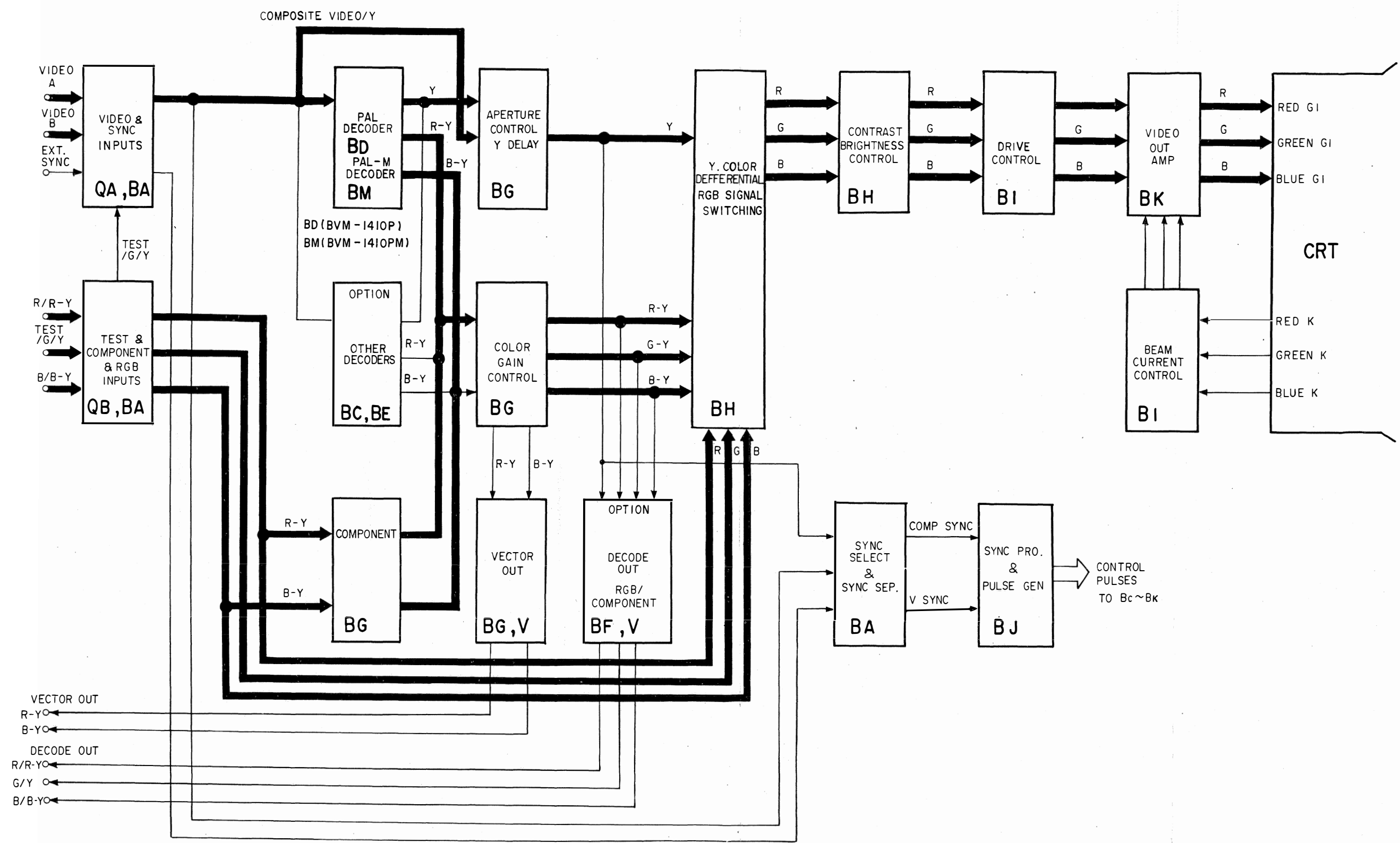

FRAME FRAME



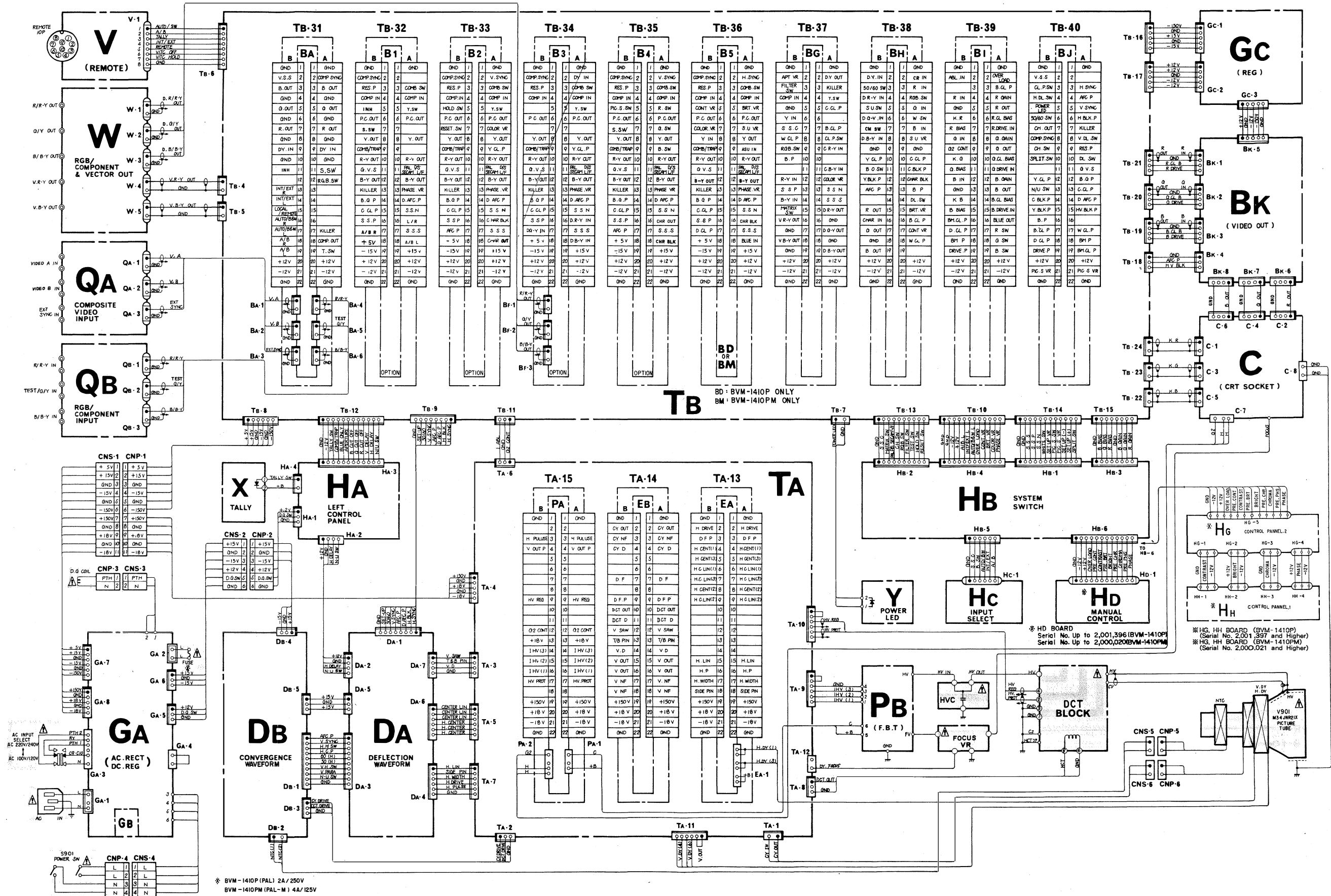



5-2. FRAME WIRING DIAGRAM



5-3. MOUNTING AND SCHEMATIC DIAGRAMS



Note:



Note: The components identified by shading and mark  are critical for safety. Replace only with part number specified.

- All capacitors are in μF unless otherwise noted. p : $\mu\mu\text{F}$
50 WV or less are not indicated except for electrolytics.
- All resistor are in ohms, 1/2W on the C board and 1/4W on the rest of the boards unless otherwise specified.
k Ω = 1000 Ω , M Ω = 1000k Ω
-  : nonflammable resistor.
- Δ : internal component.
-  : direct connection to points marked  on the chassis
-  : panel designation.
- All variable and adjustable resistors have characteristic curve B, unless otherwise noted.
- The components identified by  in this manual have been carefully factory-selected for each set in order to satisfy regulations regarding X-ray radiation. Should replacement be required, replace only with the value originally used.
When replacing components identified by , make the necessary adjustments indicated. If results do not meet the specified value, change the component identified by  and repeat the adjustment until the specified value is achieved.
Refer to R52, R53, R67, R68, R124, R126, R222, R227, R228 and R239.
Adjust on page 4-11 - 4-16.
When replacing the part in below table, be sure to perform the related adjustment.

Reference information

- RESISTOR : RN METAL FILM
: RC SOLID
: FPRD NONFLAMMABLE CARBON
: FUSE NONFLAMMABLE FUSIBLE
: RS NONFLAMMABLE WIREWOUND
: RB NONFLAMMABLE CEMENT
- COIL : LF-8L MICRO INDUCTOR
- CAPACITOR: TA TANTALUM
: PS STYROL
: PP POLYPROPYLENE
: PT MYLAR
: MPS METALIZED POLYESTER
: MPP METALIZED POLYPROPYLENE
: ALB BIPOLAR
: ALT HIGH TEMPERATURE
: AIR HIGH RIPPLE

Part replaced ()	Adjustment ()
C59, IC3, R67, R68, R78, RV2... (GA board)	+B MAX (R67, R68) Page 4-11.
Q13, Q14, R52, R53 (GA board) D5, D6, D7, D8, Q3, Q4, Q5, R4, R5, R19, R20, R21, R22... (GB board)	+B PROTECTOR (R52, R53) Page 4-11.
D216, IC1, IC4, R123, R124, R125, R126, R136, R137, R138, R203, R204, RV1... (PA board) DCT BLOCK	HV REG (R124, R126) Page 4-16.
D205, D207, D214, D215, IC2, R201, R202, R213, R214, R225, R226, R227, R228, R229, R230, R243 (PA board) DCT BLOCK	HV HOLD DOWN (R227, R228) Page 4-14 ~ 4-15.
D205, D206, D215, IC2, R201, R202, R213, R214, R220, R221, R222, R223, R224, R242... (PA board) FBT, R1, R2... (PB board)	BEAM CURRENT PROTECTOR-1 (R222) Page 4-15.
D204, D216, IC3, R203, R204, R231, R232, R237, R238, R239, R240, R241, R247... (PA board) FBT, R3, R4... (PB board)	BEAM CURRENT PROTECTOR-2 (R239) Page 4-16.



- Voltages are dc with respect to ground unless otherwise noted.
- Voltage variations may be noted due to normal production tolerances.
- Reading are taken with a 10 M Ω digital multimeter.
-  : adjustment for repair.
-  : B+ bus.
-  : B- bus.
- Circled numbers are waveform references.
- \times : Can not be measured.
- Readings and waveforms are taken with a color-bar signal input and with a 75 Ω terminator connected to an open terminal.

- Switches and controls are set as follows unless otherwise noted.

FRONT PANEL (R)

- INPUT selector A
 - SYNC selector INT
 - MODE selector AUTO
 - CONTRAST MANUAL switch PRESET
 - BRIGHTNESS MANUAL switch PRESET
 - CHROMA MANUAL switch PRESET
 - PHASE MANUAL switch PRESET
- HC board
HG board
(HD board)



FRONT PANEL (L)

- SCAN MODE switch
 -  UNDER SCAN NOR
 -  H. DELAY NOR
 -  V. DELAY NOR
 - SCREEN switch (R) NOR
 - SCREEN switch (G) NOR
 - SCREEN switch (B) NOR
 - APT switch NOR
 - BLUE ONLY switch NOR
 - COMB/TRAP filter selector TRAP
- HA board

SUB CONTROL PANEL

- INPUT SELECT buttons B
 - COLOR STANDARD buttons NTSC
 - FILTER switch OFF
 - MATRIX switch OFF
 - PAL/SECAM mode selector D(L)
 - WHITE/OPERATE/SET UP selector OPERATE
 - SPRIT SCREEN switch OFF
 - CROSS HATCH switch OFF
 - VITC switch OFF
 - PIC. SET UP switch OFF
 - AFC switch 2m sec
- HB board
DA board

Note:

-  : Conductor side pattern
-  : Component side pattern

BA board (SYNC SELECT & SYNC SEP, HOOK UP)

IC	2										3				1															
Q	717	716	715	713	708	711	707	706	703	705	702	5	3	4	2	1														
	605	604	603	602	601	505	504	503	502	501	405	404	403	402	401	305	304	303	302	301	205	204	203	202	201	105	104	103	102	101
D	708 707 706 703 705 710										101 709				4		1		2											
TP	TP702		TP601		TP701		RV501		TR401		RV401		TP2		RV201		TP501		TP1		TP201		TP101							
ADJ	RV601		CV602		CV601		CV502		CV501		CV402		CV401		CV202		CV201		RV101		CV102		CV101							

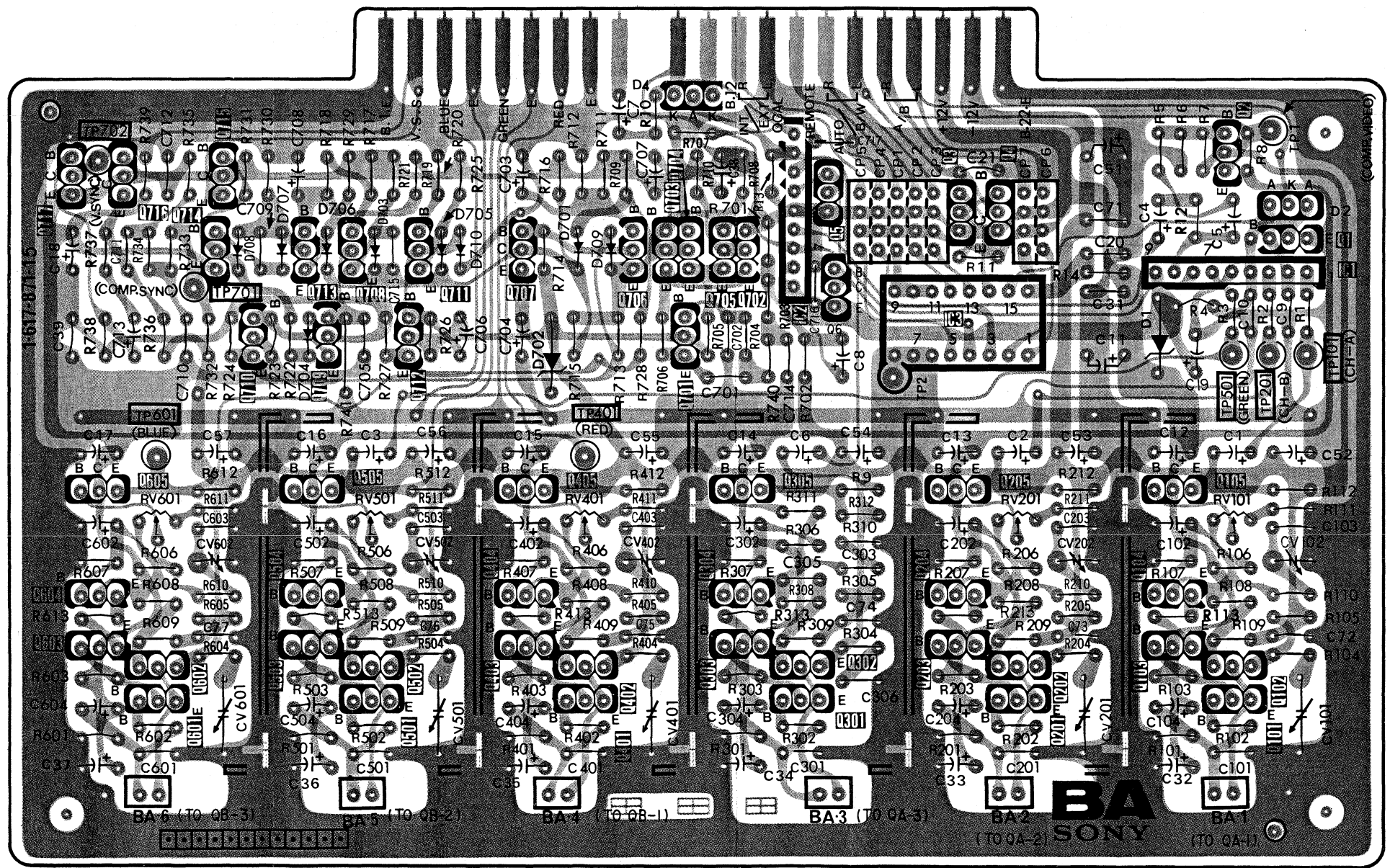

● : Conductor side pattern
 ○ : Component side pattern

BA BA

BA board (SYNC SELECT & SYNC SEP, HOOK UP)

B

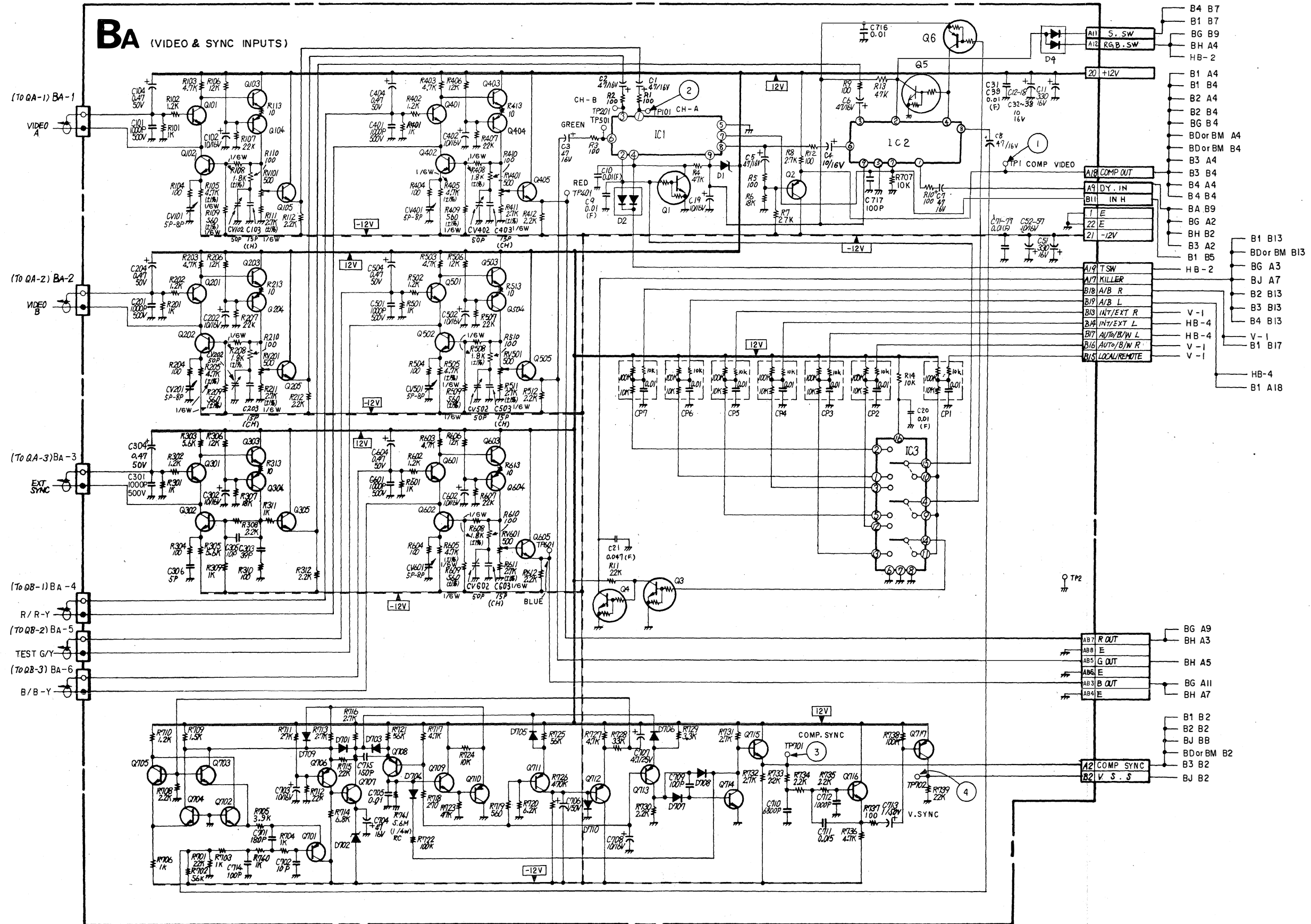

BA BOARD

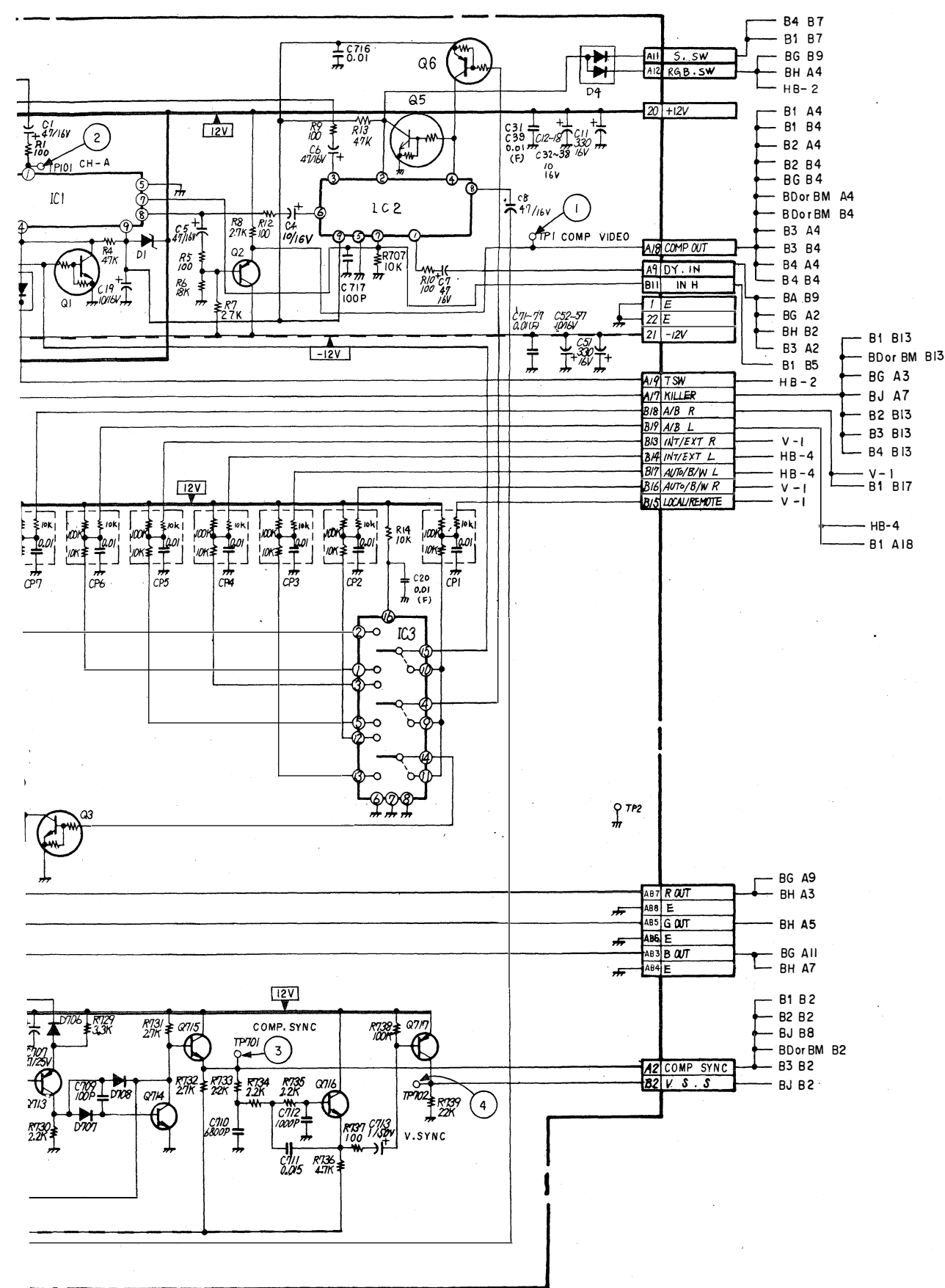

IC1	CX894	INPUT SELECT
2	CX894	SYNC SELECT
3	MC14053BCP	LOCAL/REMOTE SW
Q1	DTC144ES	INPUT SELECT CONTROL
2	2SA844	BUFF
3	DTC144ES	KILLER
4	DTC144ES	KILLER
5	DTC144ES	SYNC SELECT CONTROL
6	DTA144ES	INT/EXT CONTROL
101	2SC2668	VIDEO A AMP
102	2SC2668	VIDEO A AMP
103	2SC2668	VIDEO A AMP
104	2SA844	VIDEO A AMP
105	2SC2668	VIDEO A AMP
201	2SC2668	VIDEO B AMP
202	2SC2668	VIDEO B AMP
203	2SC2668	VIDEO B AMP
204	2SA844	VIDEO B AMP
205	2SC2668	VIDEO B AMP
301	2SC2668	EXT SYNC AMP
302	2SC2668	EXT SYNC AMP
303	2SC2668	EXT SYNC AMP
304	2SA844	EXT SYNC AMP
305	2SC2668	EXT SYNC AMP
401	2SC2668	R-Y/R AMP
402	2SC2668	R-Y/R AMP
403	2SC2668	R-Y/R AMP
404	2SA844	R-Y/R AMP
405	2SC2668	R-Y/R AMP
501	2SC2668	TEST/Y/G AMP
502	2SC2668	TEST/Y/G AMP
503	2SC2668	TEST/Y/G AMP
504	2SA844	TEST/Y/G AMP
505	2SC2668	TEST/Y/G AMP
601	2SC2668	B-Y/B AMP
602	2SC2668	B-Y/B AMP

Q603	2SC2668	B-Y/B AMP
604	2SA844-E	B-Y/B AMP
605	2SC2668	B-Y/B AMP
701	2SA1048	SYNC AGC
702	2SC2785	SYNC AGC
703	2SC2785	SYNC AGC
704	2SC2785	SYNC AGC
705	2SC2785	SYNC AGC
706	2SA1115	SYNC AGC
707	2SC3068	SYNC AGC
708	2SA1115	SYNC AGC
709	2SC2785	SYNC AGC
710	2SA1115	SYNC AGC
711	2SA1115	SYNC AGC
712	2SA1115	SYNC AGC
713	2SA1115	COMP SYNC SEP
714	2SC2785	COMP SYNC SEP
715	2SC3068	COMP SYNC SEP
716	2SC3068	V SYNC SEP
717	2SA1115	V SYNC SEP
D1	RD3.0E-B	+9V REG
2	MC921	INPUT SELECT CONTROL
4	MC911	SYNC SELECT CONTROL
701	1SS119	SYNC AGC
702	RD4.3E-B	-7.5V REG
703	1SS119	SYNC AGC
704	1SS119	SYNC AGC
705	1SS119	SYNC AGC
706	1SS119	SYNC AGC
707	1SS119	COMP SYNC SEP
708	1SS119	COMP SYNC SEP
709	1SS119	SYNC AGC
710	1SS119	SYNC AGC

5. DIAGRAMS

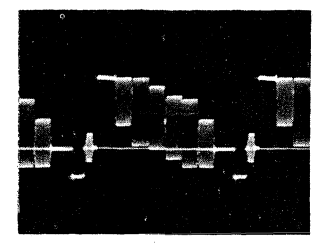

① 1Vp-p (H)
② 1Vp-p (H)

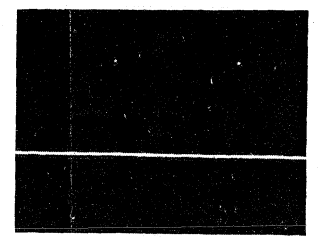

④ 12Vp-p (V)

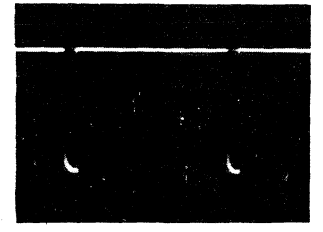

③ 11Vp-p (H)

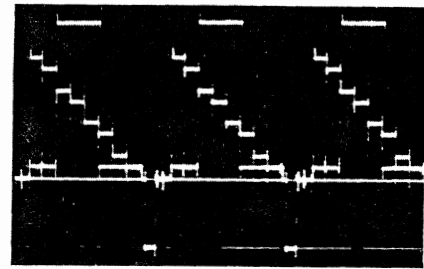

① 1Vp-p (H)

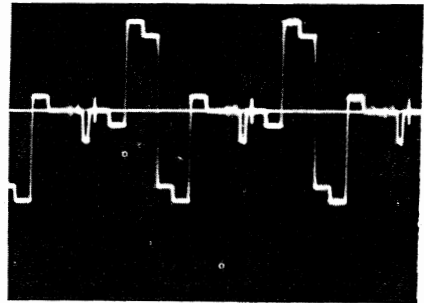

② 0.3Vp-p ④ 0.32Vp-p
③ 0.32Vp-p ⑤ 0.36Vp-p

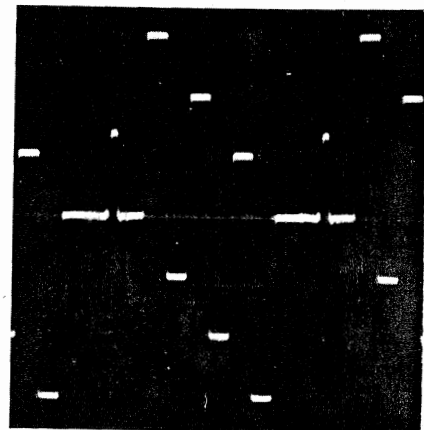

⑥ 0.38Vp-p ⑧ 0.39Vp-p
⑦ 0.38Vp-p ⑨ 0.42Vp-p

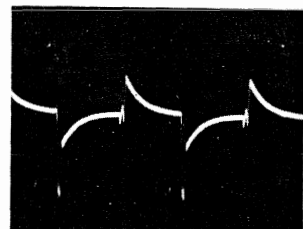

⑩ 0.26Vp-p (H)
⑪ 0.26Vp-p (H)

NOTE

Model	BD (PAL)			BM (PAL-M)		
Ref						
C1	10P	0.5P	50V	15P	5%	50V
C2	10P	0.5P	50V	15P	5%	50V
C3	33PF	5%	50V			
C4	47P	5%	50V	39P	5%	50V
C6	68P	5%	50V	56P	5%	50V
C7	33P	5%	50V	39P	5%	50V
C8	6P	0.5P	50V	2P	0.25P	50V
C20	68P	5%	(UJ) 50V	56P	5%	(UJ) 50V
C23	ELECT			FILM		
	1	20%	50V	0.01	5%	50V
C26	160P	1%	500V	130P	1%	500V
C30	160P	1%	500V	130P	1%	500V
C62	24P	5%	50V	JW		
C80				1	20%	50V
C304	10P	0.5P	50V			
C316	2P	0.25P	50V	10P	0.5P	50V
C350	33P	5%	(UJ) 50V	22P	5%	(UJ) 50V
D15				1S5119		
L3	33μH			68μH		
R4	1.5K	1%	1/6W	1K	1%	1/6W
R5	82	1%	1/6W	110	1%	1/6W
R8	1.2K	1%	1/6W	1.8K	1%	1/6W
R11	56	1%	1/6W	130	1%	1/6W
R12	1.8K	1%	1/6W	2.2K	1%	1/6W
R23	6.8K	1%	1/6W	5.6K	1%	1/6W
R28	1.8K	5%	1/4W	3.3K	5%	1/4W
R34	270	1%	1/6W	680	1%	1/6W
R35	270	1%	1/6W	680	1%	1/6W
R40	1K	1%	1/6W	1K	5%	1/4W
R41	2.2K	1%	1/6W	2.2K	5%	1/6W
R42	10K	1%	1/6W	10K	5%	1/4W
R43	1K	1%	1/6W	1K	5%	1/4W
R55	750	1%	1/6W	910	1%	1/6W
R60	750	1%	1/6W	910	1%	1/6W
R64	220K	1%	1/6W	1K	5%	1/4W
R65	3.9K	1%	1/6W	2.2K	1%	1/6W
R115	5.1K	1%	1/6W	2.2K	1%	1/6W
R116	5.1K	1%	1/6W	2.2K	1%	1/6W
R130	220K	1%	1/6W	470K	1%	1/6W
R320	130K	1%	1/6W	360K	1%	1/6W
TH1				THERMISTOR	10K	
X1	4.43MHz			3.58MHz		
X2	10.64MHz			10.717MHz		
R25	6.8K	5%	1/4W	4.7K	5%	1/4W
R26	680	5%	1/4W	1.2K	5%	1/4W
R39	1.5K	1%	1/6W	2.2K	1%	1/6W
C18	13PF	5%	50V	15PF	5%	50V
L2	1-408-532-00			1-408-514-00		

BD board (PAL DECODER Y. TRAP)
BM board (PAL-M DECODER Y. TRAP)

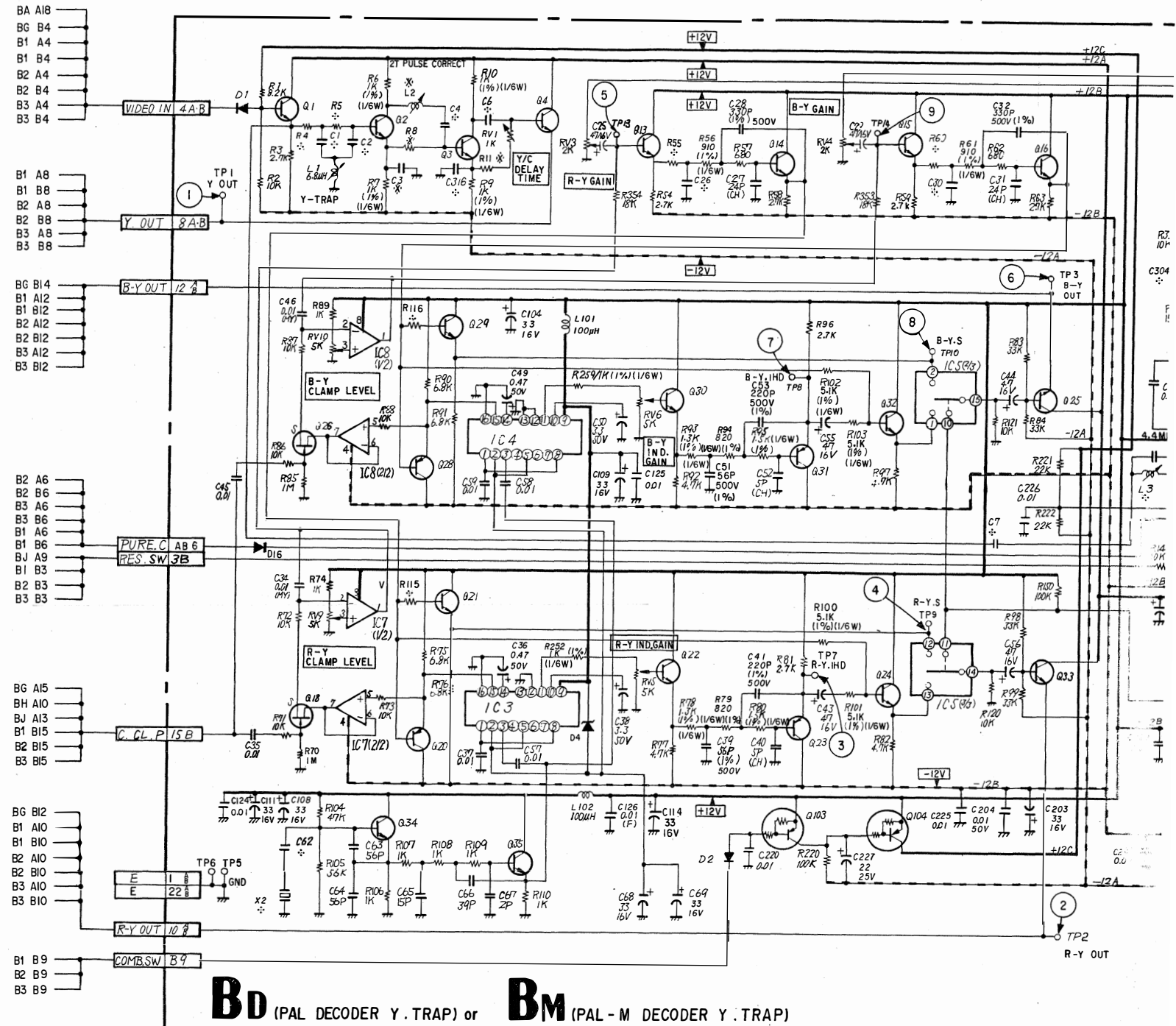

Bd (PAL DECODER Y. TRAP) or **Bm** (PAL-M DECODER Y. TRAP)

BD or BM BD or BM

BD board (PAL DECODER Y. TRAP)
 BM board (PAL-M DECODER Y. TRAP)

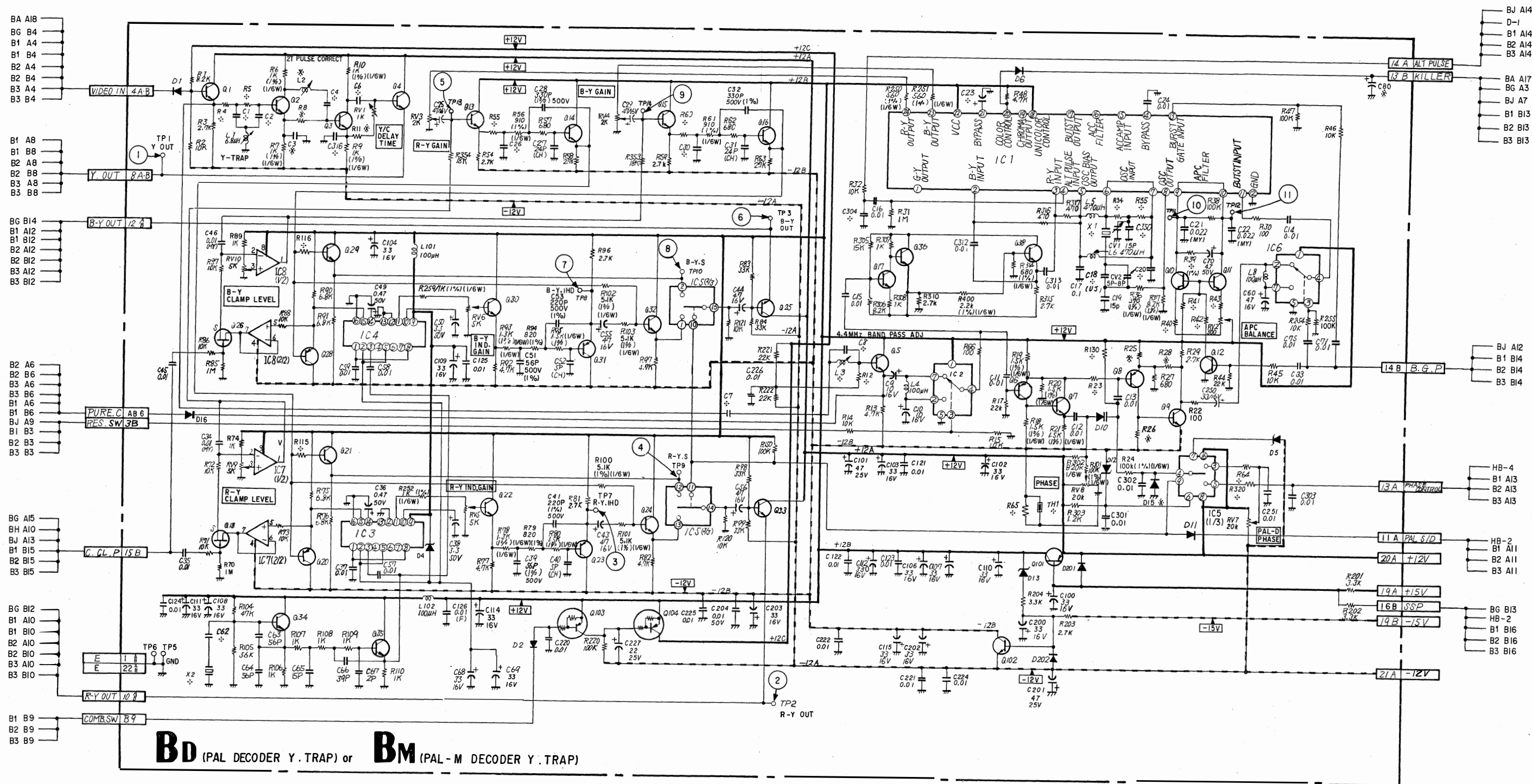

BD or BM BD or BM

BD board (PAL DECODER Y. TRAP)
 BM board (PAL-M DECODER Y. TRAP)

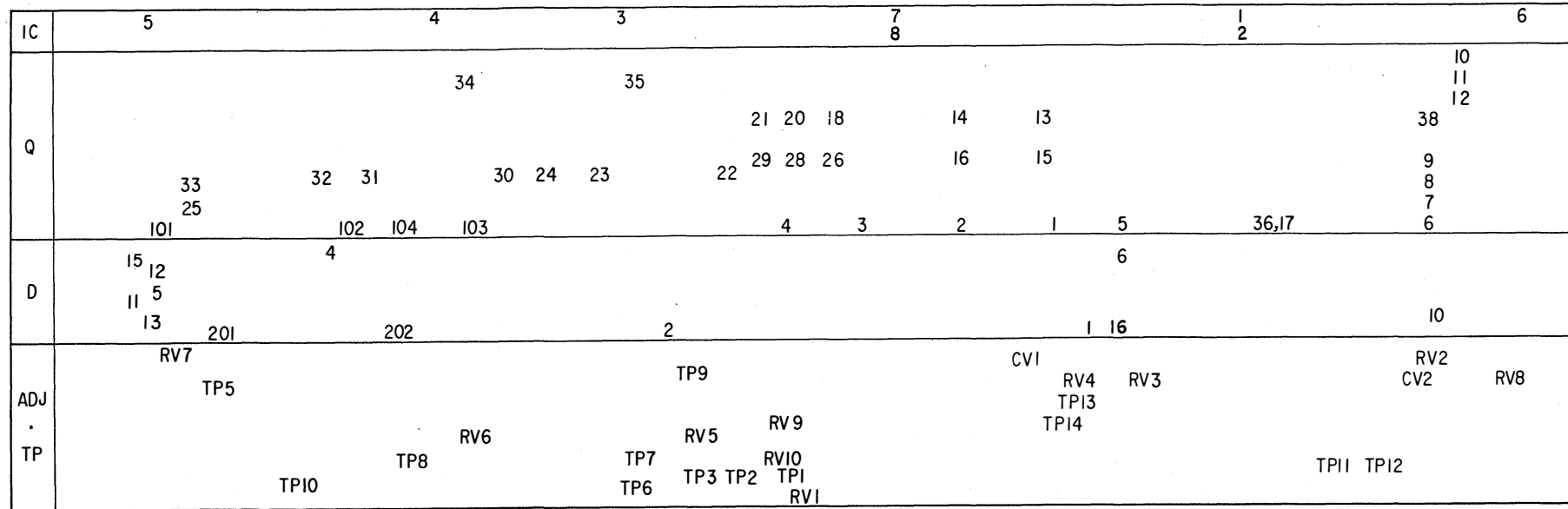

IC1	TA7193P	PAL DEMODULATOR
2	LA7016	RESIDUAL SWITCH
3	TL8608P	1H DELAY LINE
4	TL8608P	1H DELAY LINE
5	MC14053BCP	ANALOG SWITCHER
6	LA7016	BURST GATE
7	RC4558P	R-Y CLAMP
8	RC4558P	B-Y CLAMP
Q1	2SC403SP	BUFFER
2	2SC403SP	ACTIVE FILTER
3	2SC403SP	Y-DELAY CORRECTER
4	2SC3068	BUFFER
5	2SC3068	BUFFER
6	2SA844	PHASE CONTROLLER
7	2SC403SP	PHASE CONTROLLER
8	2SA844	PHASE CONT. AMP.
9	2SC403SP	PHASE CONT. AMP.
10	2SA1175	APL FILTER
11	2SA1175	APL FILTER
12	2SC403SP	APL FILTER SWITCH
13	2SC403SP	R-Y L.P.F
14	2SC403SP	R-Y L.P.F
15	2SC403SP	B-Y L.P.F
16	2SC403SP	B-Y L.P.F
17	2SC403SP	AMPLIFIER
18	2SK381	R-Y CLAMP
20	2SA1175	BUFFER
21	2SC403SP	BUFFER
22	2SC403SP	CCD OUT L.P.F
23	2SA844	CCD OUT L.P.F
24	2SC403SP	BUFFER
25	2SC3068	BUFFER
26	2SK381	B-Y CLAMP
28	2SA1175	BUFFER
29	2SC403SP	BUFFER
30	2SC403SP	CCD OUT L.P.F
31	2SA1175	CCD OUT L.P.F
32	2SC403SP	BUFFER
33	2SC3068	BUFFER
34	2SC403SP	CCD CLOCK GEN
35	2SC403SP	CCD CLOCK GEN
36	2SC403SP	BUFFER
38	2SC403SP	BUFFER
101	2SB734	SYSTEM SWITCH
102	2SD789	SYSTEM SWITCH
103	DTA124ES	COMB. SWITCH
104	DTA124ES	COMB. SWITCH
D1	1SS119	SYSTEM SWITCH
2	1SS119	COMB. SWITCH
4	RD3.0EB1	CCD BIAS
5	RD9.1EB2	SWITCH BIAS
6	1SS119	KILLER SWITCH
10	1T25	PHASE CONTROL
11	1SS119	PAL S/D SWITCH
12	RD12EB2	PHASE SWITCH
13	RD12EB2	SYSTEM SWITCH
15	1SS119	
16	1SS119	COMB SW
201	1SS119	PROTECTOR
202	1SS119	PROTECTOR

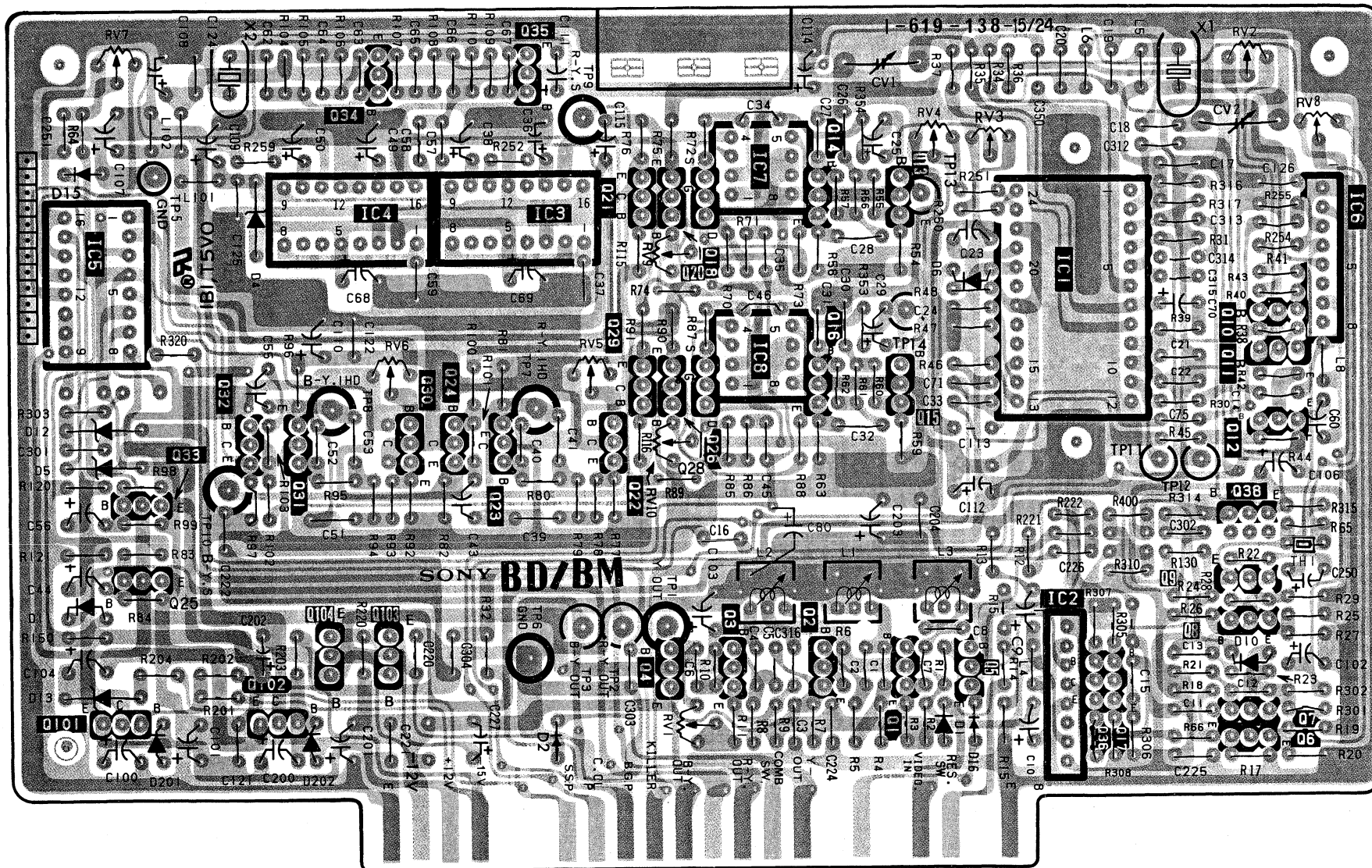

- Conductor side pattern
- Component side pattern

BG board (COLOR GAIN CONTROL, COMPONENT R-Y AMP & DELAY, APERTURE CONTROL, Y DELAY, VECTOR OUT, NTSC MATRIX SW, G-Y MATRIX AMP)

IC				3				5		8
				6	4		7			9
Q										
D										
TP										
ADJ										

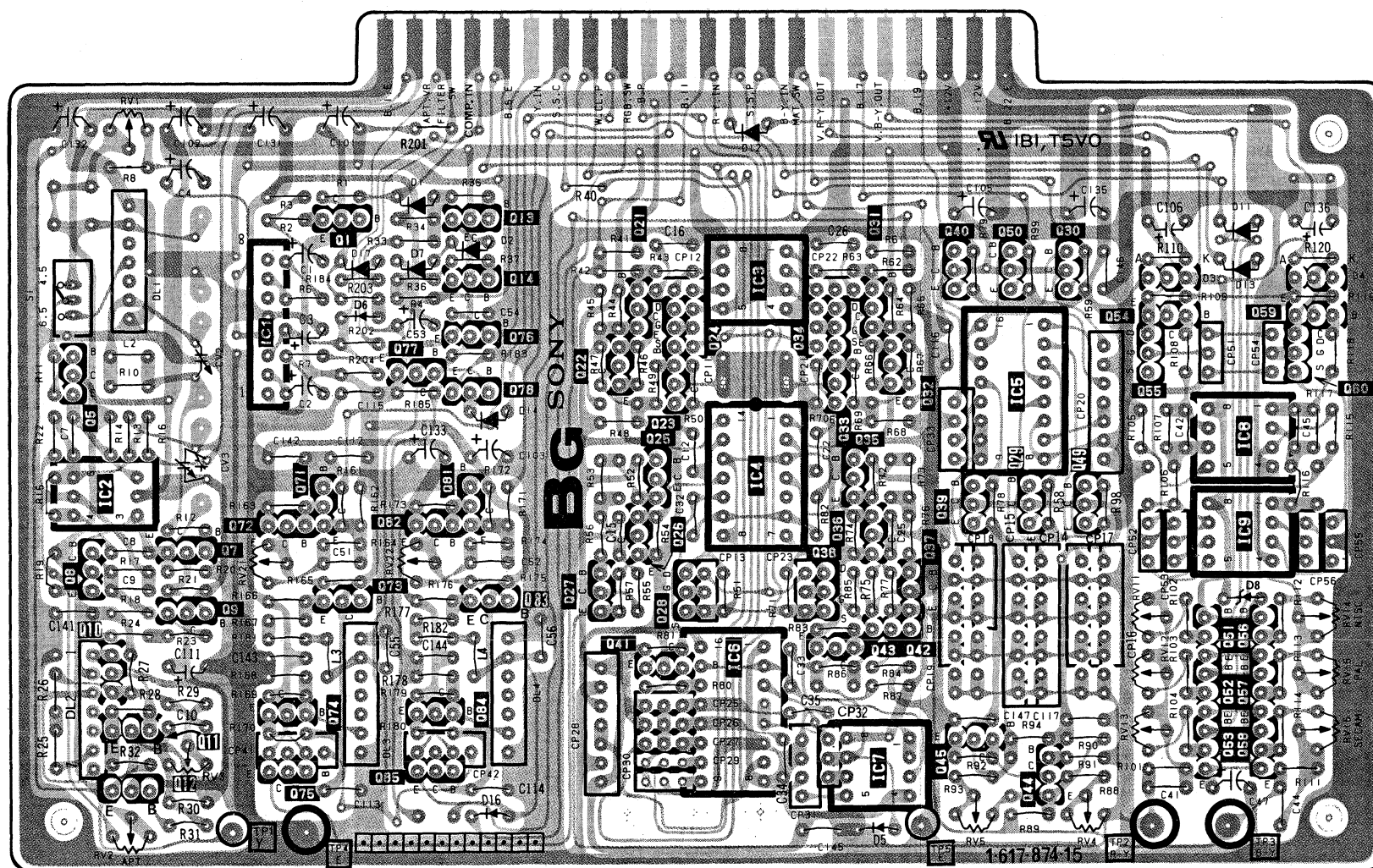

- : Conductor side pattern
- : Component side pattern

BG board (COLOR GAIN CONTROL, COMPONENT R-Y AMP & DELAY, APERUTURE CONTROL, Y DERAY. VECTOR OUT NTSC MATRIX SW, G-Y MATRIX AMP)

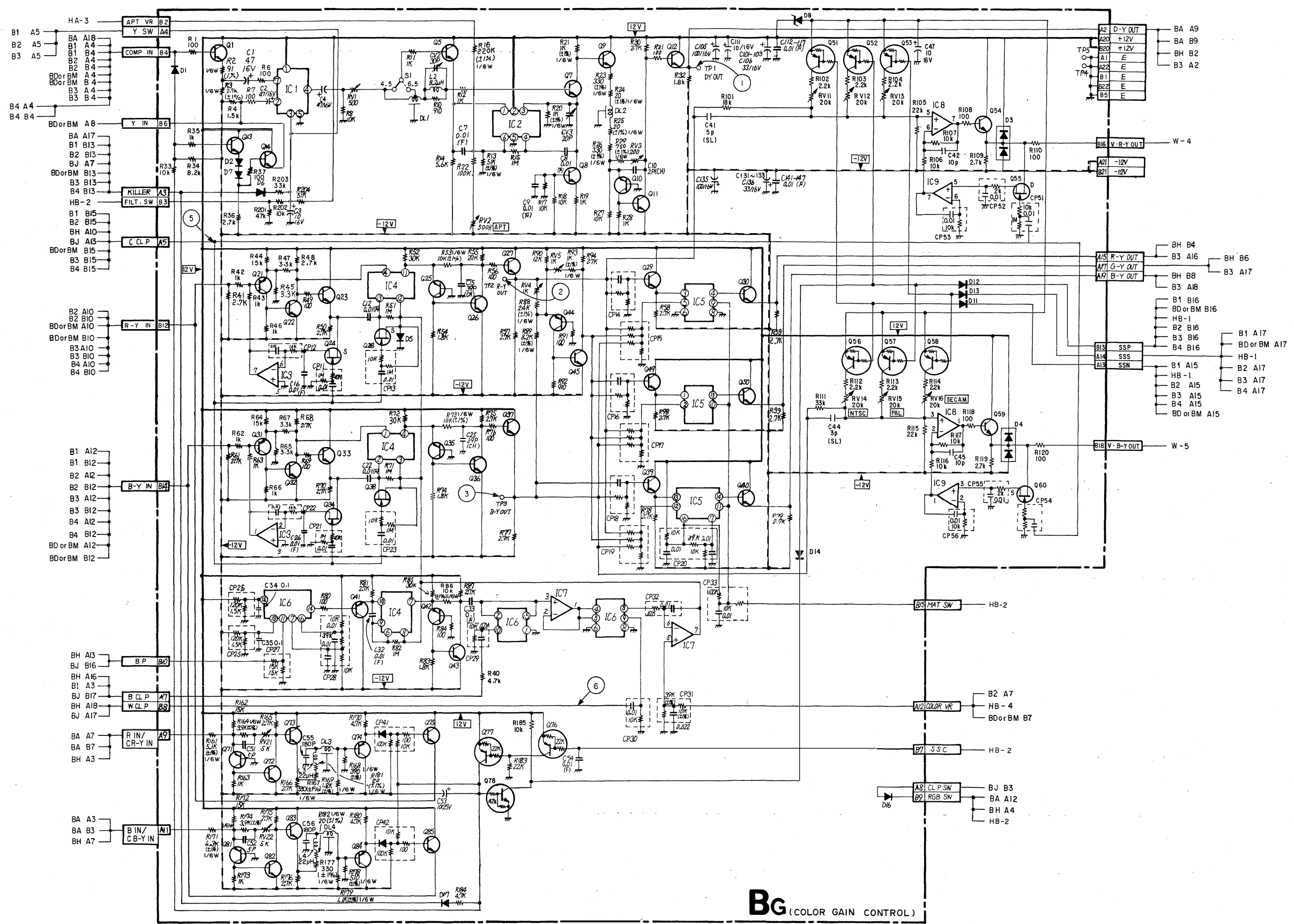

BG (COLOR GAIN CONTROL)

BG BOARD

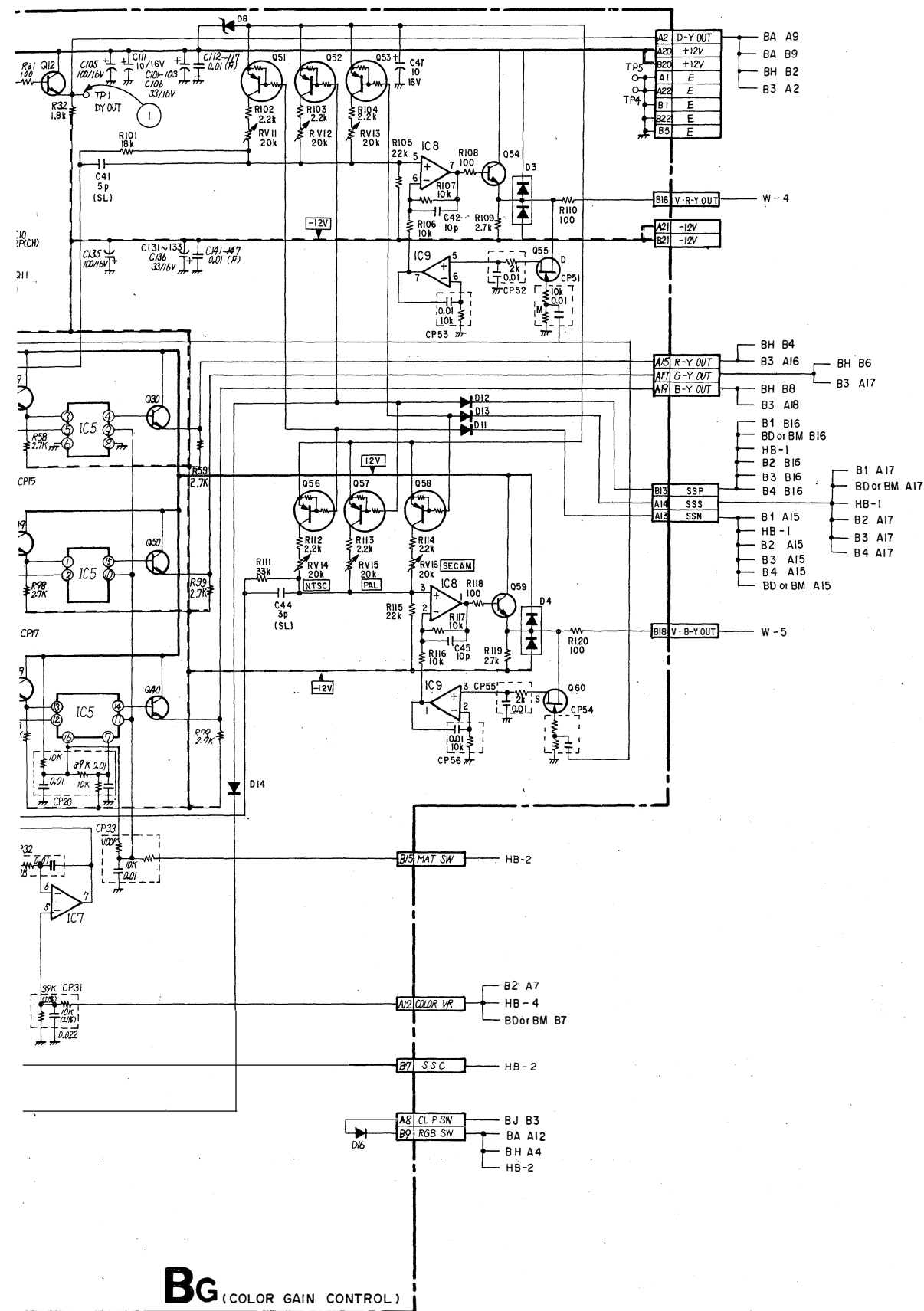

BG (COLOR GAIN CONTROL)

IC1	LA7016	FILTER SW
2	TX-429M	APERTURE
3	RC4558DQ	COLOR DIFFERENCE CLAMP
4	CX-718D	CHROMA CONTROL
5	MC14053BCP	MATRIX SW
6	MC14053BCP	CHROMA CONTROL
7	TL082CP	CHROMA CONTROL
8	TL082CP	VECTOR OUTPUT
9	TL082CP	VECTOR OUTPUT
Q1	2SC403SP	BUFF
5	2SC403SP	APERTURE
7	2SC403SP	APERTURE
8	2SC403SP	APERTURE
9	2SC403SP	Y DELAY
10	2SA844	Y AMP
11	2SC403SP	Y AMP
12	2SC403SP	Y AMP
13	2SC403SP	BUFF
14	2SC3068	BUFF
21	2SA844	R-Y AMP
22	2SC403SP	R-Y AMP
23	2SC403SP	R-Y CLAMP
24	2SK381	R-Y CLAMP
25	2SA844	R-Y CHROMA CONTROL
26	2SC403SP	R-Y CHROMA CONTROL
27	2SC403SP	R-Y CHROMA CONTROL
28	2SK381	R-Y CHROMA CONTROL
29	2SC403SP	R-Y BUFF
30	2SC403SP	R-Y BUFF
31	2SA844	B-Y AMP
32	2SC403SP	B-Y AMP
33	2SC403SP	B-Y CLAMP
34	2SK381	B-Y CLAMP
35	2SA844	B-Y CHROMA CONTROL
36	2SC403SP	B-Y CHROMA CONTROL
37	2SC403SP	B-Y CHROMA CONTROL
38	2SK381	B-Y CHROMA CONTROL
39	2SC403SP	B-Y BUFF
40	2SC403SP	B-Y BUFF
41	2SA844	CHROMA CONTROL
42	2SA844	CHROMA CONTROL
43	2SC403SP	CHROMA CONTROL

Q44	2SA844	CHROMA CONTROL
45	2SC403SP	CHROMA CONTROL
49	2SC403SP	G-Y BUFF
50	2SC403SP	G-Y BUFF
51	DTA124ES	GAIN CHANGE SW
52	DTA124ES	GAIN CHANGE SW
53	DTA124ES	GAIN CHANGE SW
54	2SC403SP	R-Y BUFF
55	2SK381	R-Y CLAMP
56	DTA124ES	GAIN CHANGE SW
57	DTA124ES	GAIN CHANGE SW
58	DTA124ES	GAIN CHANGE SW
59	2SC403SP	B-Y BUFF
60	2SK381	B-Y CLAMP
71	2SA844	R-Y AMP
72	2SC403SP	R-Y AMP
73	2SC403SP	R-Y AMP
74	2SA844	R-Y DELAY
75	2SC3068	R-Y BUFF
76	DTA124ES	COMPONENT SW
77	DTA124ES	COMPONENT SW
78	DTC144ES	COMPONENT SW
81	2SA844	B-Y AMP
82	2SC403SP	B-Y AMP
83	2SC403SP	B-Y AMP
84	2SA844	B-Y DELAY
85	2SC3068	B-Y BUFF
D1	1SS119	COMPONENT SW
2	1SS119	DC SHIFT SW
3	MC932	PROTECT
4	MC932	PROTECT
5	1SS119	PROTECT
6	RD6.2EB2	DC SHIFT
7	1SS119	FILTER SW
8	RD6.2E-B	+6V REG
11	1SS119	GAIN CHANGE SW
12	1SS119	GAIN CHANGE SW
13	1SS119	GAIN CHANGE SW
14	1SS119	GAIN CHANGE SW
16	1SS119	R.G.B. SW
17	1SS119	KILLER

5. DIAGRAMS

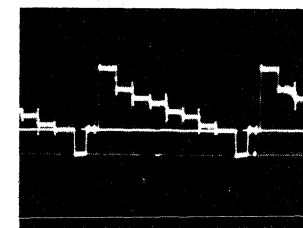

① 1Vp-p (H)

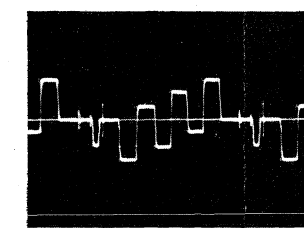

③ 1.6Vp-p (H)

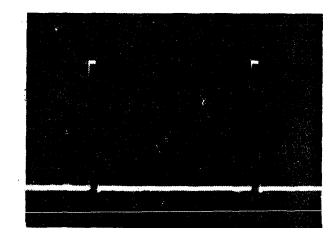

⑤ 5Vp-p (H)

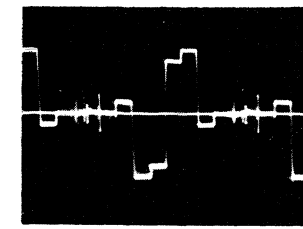

② 1.4Vp-p (H)

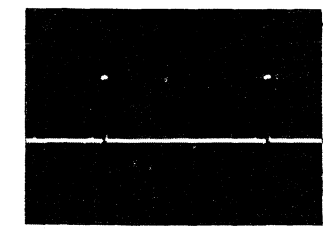

⑥ 6Vp-p (H)

BH BOARD

IC1(1/3)	TC4053BP	COMPOSITE/R.G.B. CHANGE SW
(2/3)		SET UP & CROSS HATCH SW
(3/3)		SCREENING SW
2(1/3)	TC4053BP	COMPOSITE/R.G.B. CHANGE SW
(2/3)		SET UP SW
(3/3)		SCREENING SW
3(1/3)	TC4053BP	COMPOSITE/R.G.B. CHANGE SW
(2/3)		SET UP SW
(3/3)		SCREENING SW
4(1/3)	TC4053BP	COMPOSITE/R.G.B. CHANGE SW
(2/3)		SET UP SW
(3/3)		SCREENING SW
5	RC4558S	SAMPLE HOLD
6	RC4558S	SAMPLE HOLD
7	LA7016	BLUE ONLY SW
8	LA7016	BLUE ONLY SW
9	MC14053BCP	AGC PULSE, SET UP, WHITE, VITC INSERT GEN
10(1/2)	MC14053BCP	AGC PULSE, SET UP, WHITE, VITC INSERT GEN
(2/2)		COLOR DIFFERENCE & R.G.B. SCREENING PULSE GEN
11(1/4)	MC14081BCP	AGC PULSE, SET UP, WHITE, VITC INSERT GEN
(3/4)		COLOR DIFFERENCE & R.G.B. SCREENING PULSE GEN
(2/4)		Y SCREENING PULSE GEN
12	MC14081BCP	AGC PULSE, SET UP, WHITE, VITC INSERT GEN
13	MC14001BCP	AGC PULSE, SET UP, WHITE, VITC INSERT GEN
14	TC4030BP	AGC PULSE, SET UP, WHITE, VITC INSERT GEN
101	TX-429M	R CONTRAST CONTROL
102	TL082CP	R CONTRAST & BRIGHT CONTROL
201	TX-429M	G CONTRAST CONTROL
202	TL082CP	G CONTRAST & BRIGHT CONTROL
301	TX-429M	B CONTRAST CONTROL
302	TL082CP	B CONTRAST & BRIGHT CONTROL
Q1	2SC403SP	Y BUFF
2	2SK523	Y SAMPLE HOLD
3	2SA844	Y BUFF
4	2SC403SP	R-Y/R BUFF

Q5	2SK523	R-Y/Y SAMPLE HOLD
6	2SA844	R-Y/R BUFF
7	2SC403SP	G-Y/R BUFF
8	2SK523	G-Y/Y SAMPLE HOLD
9	2SA844	G-Y/G BUFF
10	2SC403SP	B-Y/B BUFF
11	2SK523	B-Y/B SAMPLE HOLD
12	2SA844	B-Y/B BUFF
13	2SA844	R BUFF
14	2SA844	G BUFF
15	2SA844	B BUFF
16	2SC3068	AGC PULSE BUFF
101	2SK381	R CONTRAST CONTROL
102	2SA844	R AMP
103	2SC403SP	R AMP
104	2SC403SP	R LIMITER
105	2SC403SP	R LIMITER
106	2SK381	R BRIGHT CONTROL
107	2SK381	R CONTRAST CONTROL
108	2SK381	R CONTRAST CONTROL
201	2SK381	G CONTRAST CONTROL
202	2SA844	G AMP
203	2SC403SP	G AMP
204	2SC403SP	G LIMITER
205	2SC403SP	G LIMITER
206	2SK381	G BRIGHT CONTROL
207	2SK381	G CONTRAST CONTROL
208	2SK381	G CONTRAST CONTROL
301	2SK381	B CONTRAST CONTROL
302	2SA844	B AMP
303	2SC403SP	B AMP
304	2SC403SP	B LIMITER
305	2SC403SP	B LIMITER
306	2SK381	B BRIGHT CONTROL
307	2SK381	B CONTRAST CONTROL
308	2SK381	B CONTRAST CONTROL
D1	1SS119	
101	1SS119	R LIMITER
102	1SS119	R PROTECT
201	1SS119	G LIMITER
202	1SS119	G PROTECT
301	1SS119	B LIMITER
302	1SS119	B PROTECT

5. DIAGRAMS

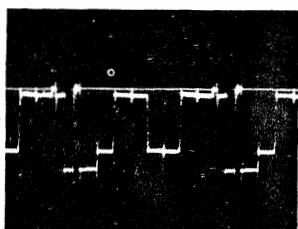

① 0.7Vp-p (H)

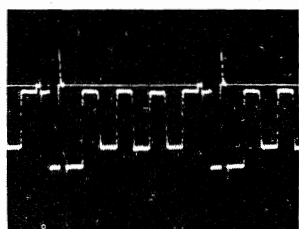

③ 0.7Vp-p (H)

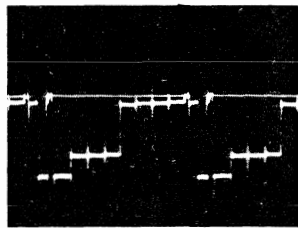

② 0.7Vp-p (H)

BH board (Y/COLOR DIFFERENCE/RGB SIGNAL SWITCHING, Y-C MATRIX, CONTRAST/BRIGHTNESS CONTROL)

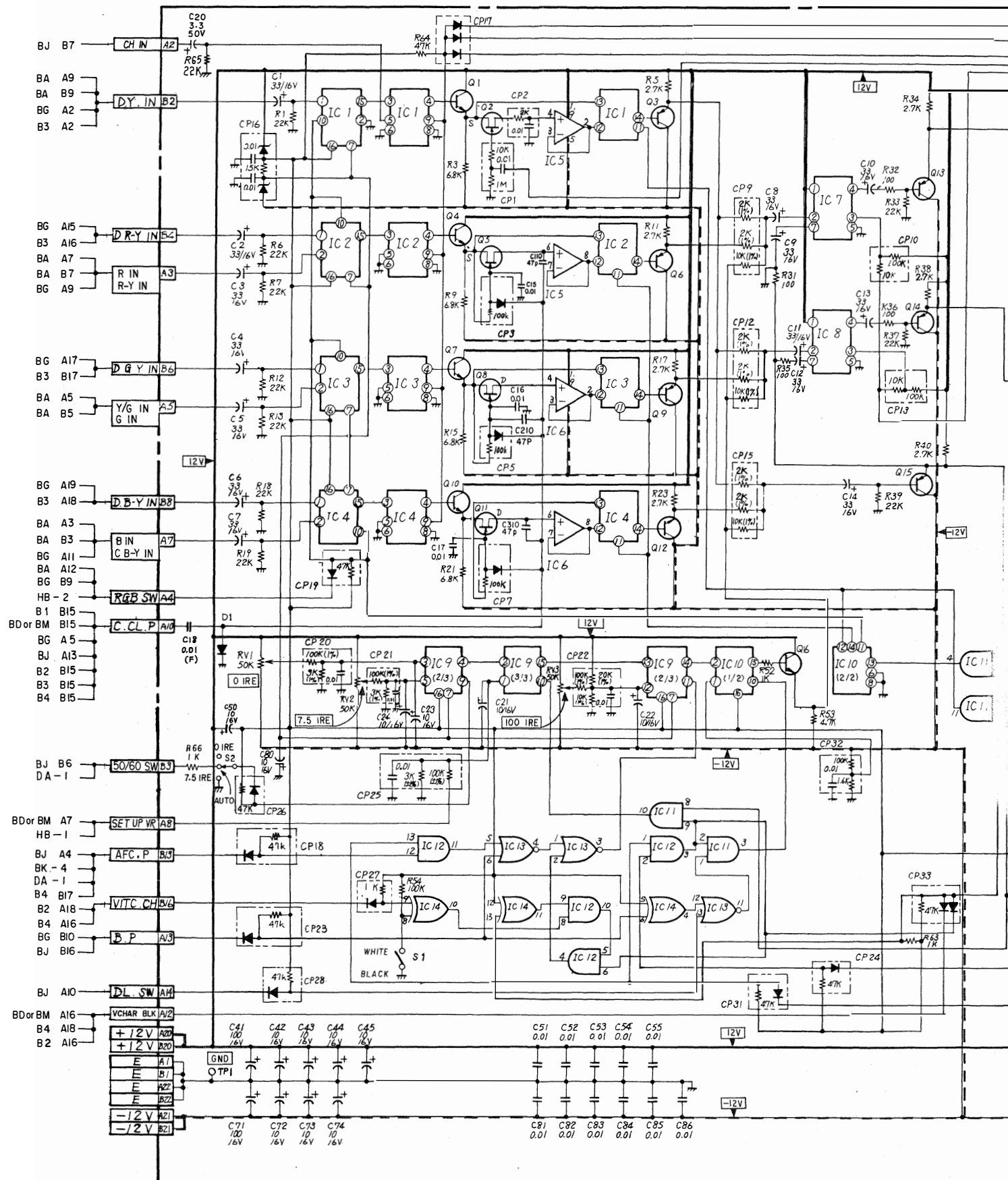

BH board (Y/COLOR DIFFERENCE/RGB SIGNAL SWITCHING, Y-C MATRIX, CONTRAST/BRIGHTNESS CONTROL)

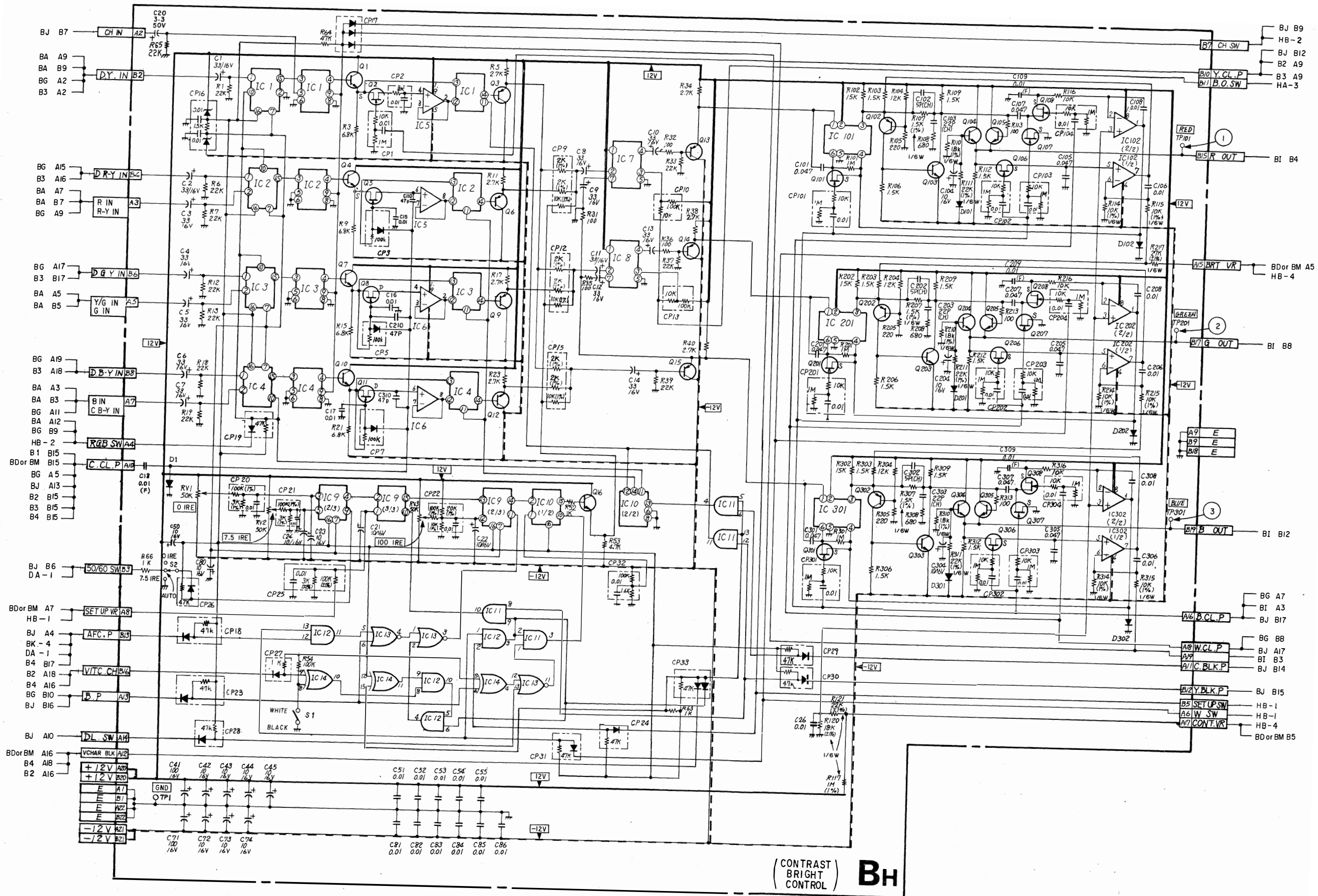

(CONTRAST BRIGHT CONTROL) BH

BH BH

BH board (Y/COLOR DIFFERENCE/RGB SIGNAL SWITCHING, Y-C MATRIX, CONTRAST/BRIGHTNESS CONTROL)

IC		9 4 3 2 1		10 6 5		8 7		11 15 14 13		12 301 201 101		13 302 202 102		14 304 305 204 203 205 104 105		202 306 307 308 206 207 208 106 107 108	
Q	10 7 4 1		12 11 8 9 6 5 2 3		16												
D																	
TP ADJ																	
			RV1 RV2 RV3							TP1							TP201 TP101 TP301

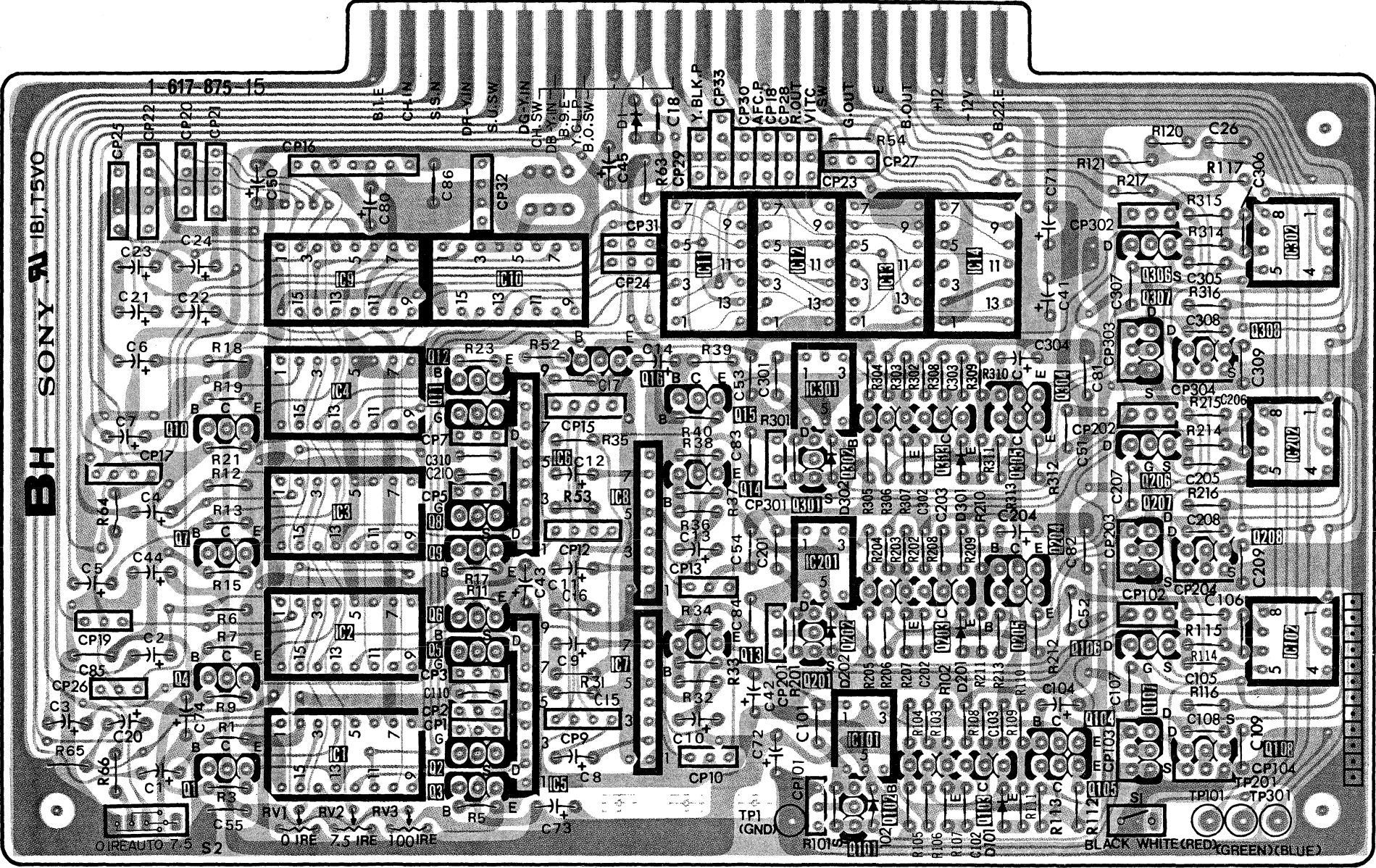

BI BI

BI board (DRIVE CONTROL, BEAM CURRENT CONTROL)

IC	101	102	103	104	105	201	202	203	204	205	301	302	303	304	305	
Q	102 103 101	108 107 106	114 105	113 109	110	202 203 201	208 207 206	205	210	214 14 13 12 11	213	302 303 301	307 306 305	314 308 310	313 309	15
D	5	7	4 1 104	2 102	6 103	101	105	201	204 203	202	205	301	304 303	302	305	8
TP	TP1															

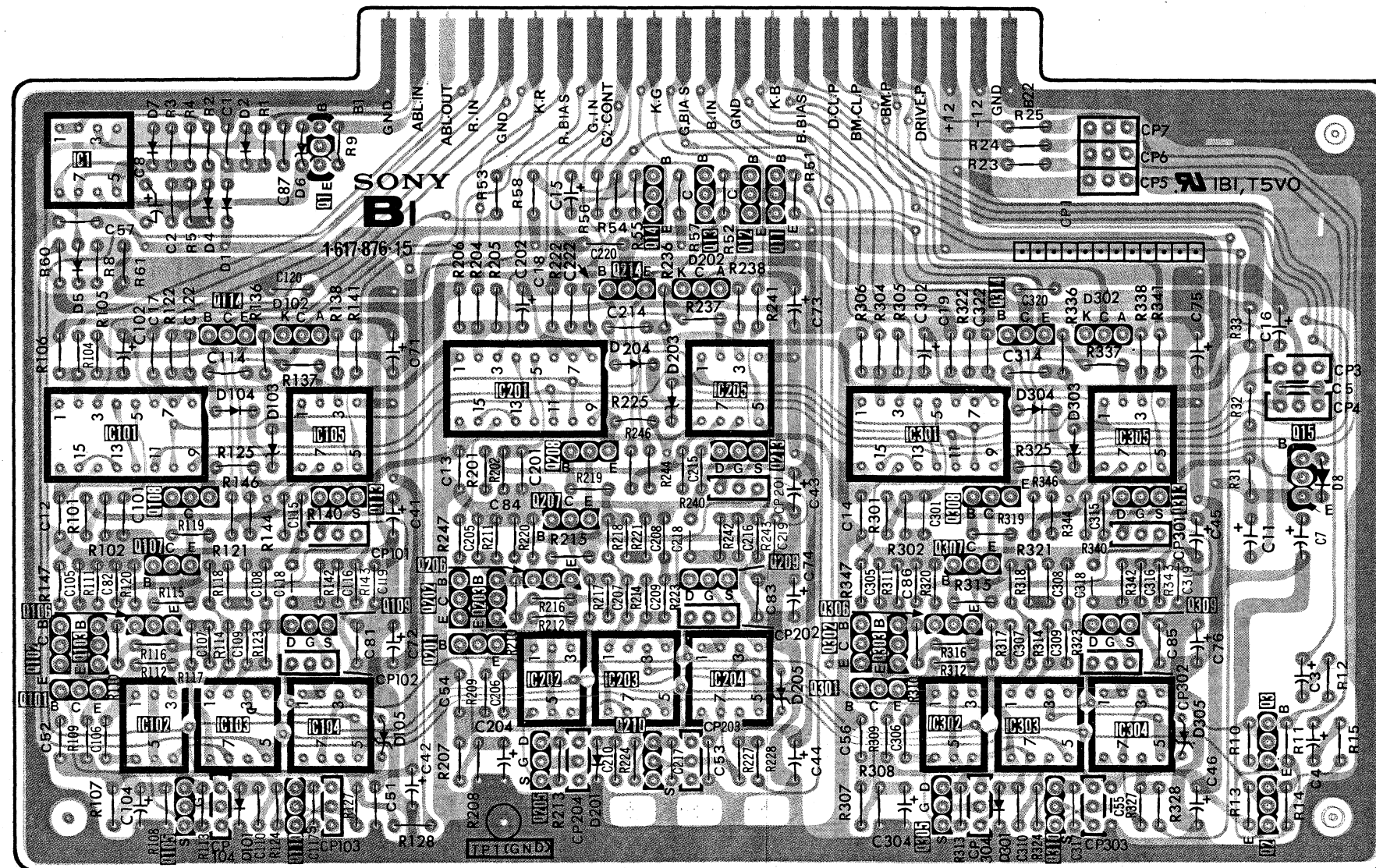

● : Conductor side pattern
 ● : Component side pattern

BI board (DRIVE CONTROL, BEAM CURRENT CONTROL)

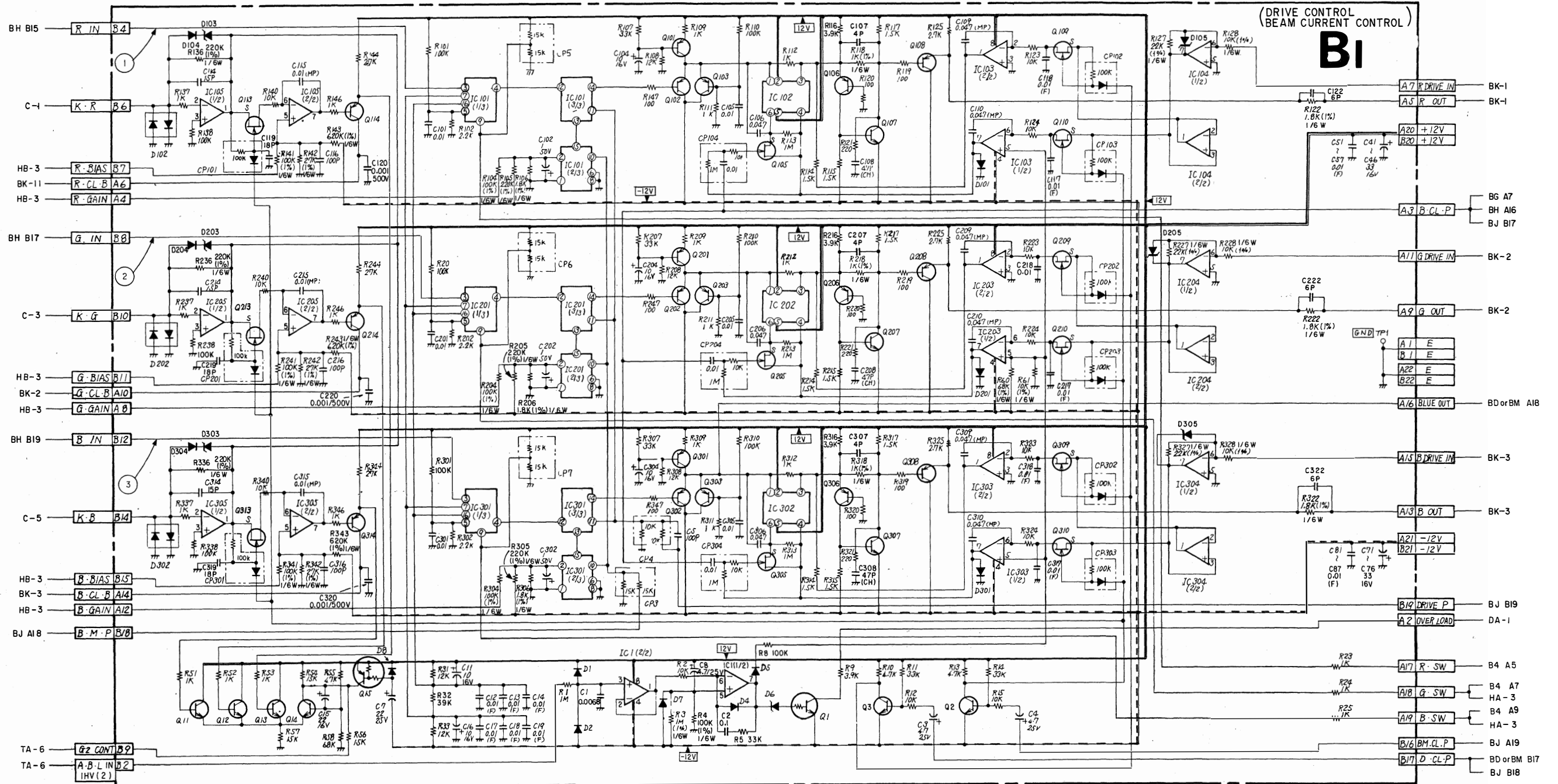

BI BOARD

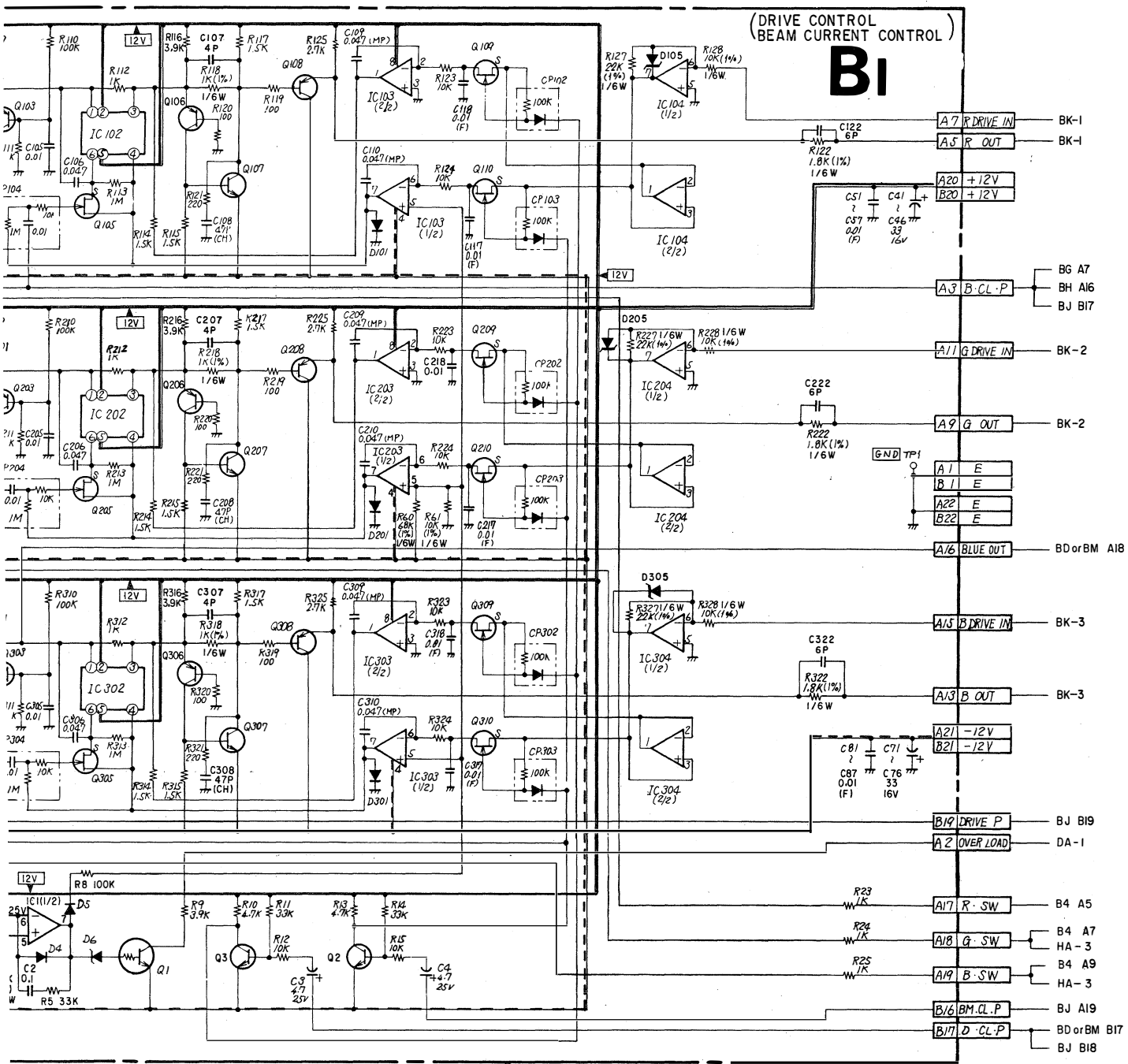

IC1	RC4558DQ	ABL
101(1/3)	TC4053BP	SCREEN OFF SW
(2/3)	TC4053BP	AGC PULSE GEN
(3/3)	TC4053BP	AGC PULSE INSERT
102	TX-429M	GAIN CONTROL
103(1/2)	TL082CP	GAIN CONTROL
(2/2)	TL082CP	BIAS CONTROL
104	TL082CP	AMP
105(1/2)	TL082CP	I-V CONVERTER
(2/2)	TL082CP	CURRENT FEEDBACK CONTROL
201(1/3)	TC4053BP	SCREEN OFF SW
(2/3)	TC4053BP	AGC PULSE GEN
(3/3)	TC4053BP	AGC PULSE INSERT
202	TX-429M	GAIN CONTROL
203(1/2)	TL082CP	GAIN CONTROL
(2/2)	TL082CP	BIAS CONTROL
204	TL082CP	AMP
205(1/2)	TL082CP	I-V CONVERTER
(2/2)	TL082CP	CURRENT FEEDBACK CONTROL
301(1/3)	TC4053BP	SCREEN OFF SW
(2/3)	TC4053BP	AGC PULSE GEN
(3/3)	TC4053BP	AGC PULSE INSERT
302	TX-429M	GAIN CONTROL
303(1/2)	TL082CP	GAIN CONTROL
(2/2)	TL082CP	BIAS CONTROL
304	TL082CP	AMP
305(1/2)	TL082CP	I-V CONVERTER
(2/2)	TL082CP	CURRENT FEEDBACK CONTROL
Q1	DTC143TS	OVER LOAD LED DRIVE
2	2SC403SP	PULSE SHAPING
3	2SC403SP	PULSE SHAPING
11	2SC2878	G2 CONTROL
12	2SC2878	G2 CONTROL
13	2SC2878	G2 CONTROL
14	2SC2878	G2 CONTROL
15	DTA144ES	G2 CONTROL
101	2SA844	LIMITER
102	2SA844	LIMITER
103	2SA844	LIMITER
105	2SK381	GAIN CONTROL
106	2SA844	AMP
107	2SC2668	AMP
108	2SA844	AMP
109	2SK381	SAMPLE-HOLD

Q110	2SK381	SAMPLE-HOLD
113	2SK381	SAMPLING
114	2SA1091	CLAMP BIAS CONTROL
201	2SA844	LIMITER
202	2SA844	LIMITER
203	2SA844	LIMITER
205	2SK381	GAIN CONTROL
206	2SA844	AMP
207	2SC2668	AMP
208	2SA844	AMP
209	2SK381	SAMPLE-HOLD
210	2SK381	SAMPLE-HOLD
213	2SK381	SAMPLING
214	2SA1091	CLAMP BIAS CONTROL
301	2SA844	LIMITER
302	2SA844	LIMITER
303	2SA844	LIMITER
305	2SK381	GAIN CONTROL
306	2SA844	AMP
307	2SC2668	AMP
308	2SA844	AMP
309	2SK381	SAMPLE-HOLD
310	2SK381	SAMPLE-HOLD
313	2SK381	SAMPLING
314	2SA1091	CLAMP BIAS CONTROL
D1	1SS119	PROTECTOR
2	1SS119	PROTECTOR
4	1SS119	ABL
5	1SS119	ABL
6	RD12ESB1	OVER LOAD LED DRIVE
7	1SS119	ABL
8	1SS119	G2 CONTROL
101	1SS119	PROTECTOR
102	MC932	PROTECTOR
103	RD4.3ES-T1B	LIMITER
104	1SS119	LIMITER
201	1SS119	PROTECTOR
202	MC932	PROTECTOR
203	RD4.3ES-T1B	LIMITER
204	1SS119	LIMITER
301	1SS119	PROTECTOR
302	MC932	PROTECTOR
303	RD4.3ES-T1B	LIMITER
304	1SS119	LIMITER
D105	RD6.2ESB	
D205	RD6.2ESB	
D305	RD6.3ESB	

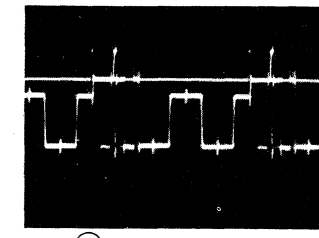

① 1.0Vp-p(H)

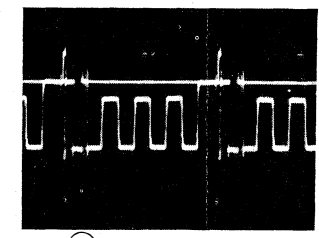

③ 1.0Vp-p(H)

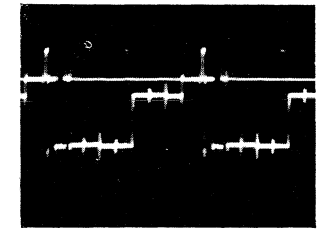

② 1.0Vp-p(H)

5. DIAGRAMS

BJ BOARD

IC1	HD14538BP	PIC.SET.PULSE GEN
2	MC14001BCP	CROSS HATCH GEN
3	TC4040BP	V SYNC & DELAY
4	TC4040BP	V COUNT
5	TC504027BP	V SYNC & DELAY
6(1/2)	TC504027BP	CHROMA CLAMP PULSE GEN
(2/2)	TC504027BP	2FH MULTI
7	TC504027BP	V COUNT
8	TC504027BP	1H PULSE PROCESS
9(1/2)	TC4027BP	V SYNC & DELAY
(2/2)	TC4027BP	1H PULSE PROCESS
10(1/2)	HD14538BP	B.G.P GEN 2
(2/2)	HD14538BP	H CYCLE
11(1/2)	HD14538BP	CROSS HATCH GEN
(2/2)	HD14538BP	SPLIT Y BLK, C BLK PULSE GEN
12	HD14538BP	Y CYCLE AGC & CLAMP PULSE GEN
13(1/4)	MC14001BCP	CHROMA CLAMP PULSE GEN
(2/4)	MC14001BCP	Y.CL.P GEN
(3/4)	MC14001BCP	B.G.P GEN 2
(4/4)	MC14001BCP	RESIDUAL PULSE GEN
14(1/4)	MC14001BCP	SPLIT Y BLK: C BLK PULSE GEN
(3/4)	MC14001BCP	V CYCLY AGC & CLAMP PULSE GEN
(4/4)	MC14001BCP	V CYCLE AGC & CLAMP PULSE GEN
15	MC14071BCP	CROSS HATCH GEN
16(1/4)	MC14011BCP	Y CYCLE AGC & CLAMP PULSE GEN
(2/4)	MC14011BCP	H OR V BLK, P
(3/4)	MC14011BCP	SPLIT Y BLK, C BLK PULSE GEN
(4/4)	MC14011BCP	CROSS HATCH GEN
17	MC14011BCP	CROSS HATCH GEN
18	TC4023BP	V COUNT
19(1/4)	MC14081BCP	V SYNC & DELAY
(2/4)	MC14081BCP	2FH MULTI
(3/4)	MC14081BCP	1H PULSE PROCESS
(4/4)	MC14081BCP	V COUNT
20	MC14081BCP	V COUNT
21(1/4)	MC14071BCP	V SYNC & DELAY
(2/4)	MC14071BCP	V COUNT
(3/4)	MC14071BCP	2FH MULTI
(4/4)	MC14071BCP	V COUNT
22(1/4)	MC14071BCP	V SYNC & DELAY
(2/4)	MC14071BCP	V COUNT
(3/4)	MC14071BCP	V SYNC & DELAY
(4/4)	MC14071BCP	V SYNC & DELAY

IC23(1/3)	TC4073BP	V SYNC & DELAY
(2/3)	TC4073BP	V COUNT
(3/3)	TC4073BP	V SYNC & DELAY
24(1/5)	MC14069UBCP	CROSS HATCH GEN
(4/5)	MC14069UBCP	V COUNT
(5/5)	MC14069UBCP	1H PULSE PROCESS
25(1/6)	MC14069UBCP	H OR V BLK.P
(2/6)	MC14069UBCP	Y CYCLE AGC & CLAMP PULSE GEN
(3/6)	MC14069UBCP	CROSS HATCH GEN
(4/6)	MC14069UBCP	1H PULSE PROCESS
(5/6)	MC14069UBCP	CLAMP PULSE CHANGE SW
(6/6)	MC14069UBCP	CROSS HATCH GEN
26	HC14175BCP	1H PULSE PROCESS
27(1/3)	MC14053BCP	CROSS HATCH GEN
(2/3)	MC14053BCP	H OR V DL SW
(3/3)	MC14053BCP	CROSS HATCH GEN
28	TC4520BP	B.G.P GEN 1
29(1/2)	HD14538BP	Y.CL.P GEN
(2/2)	HD14538BP	Y.CL.P GEN
Q14	2SC2785	CROSS HATCH GEN
15	2SC2785	Y.CL.P GEN
16	2SC2785	Y.CL.P GEN
17	2SC2785	CHROMA CLAMP PULSE GEN
18	2SC2785	CHROMA CLAMP PULSE GEN
19	2SA1115	H CYCLE
20	2SC2785	H CYCLE
21	2SC2785	H CYCLE
22	2SC2785	H CYCLE
23	2SA1048	H CYCLE
24	2SC2785	H CYCLE
25	2SC2785	CHROMA CLAMP PULSE GEN
26	2SC2785	Y.CL.P GEN
D1	1SS119	CROSS HATCH GEN
2	1SS119	H CYCLE
3	1SS119	H CYCLE
7	1SS119	1H PULSE PROCESS
8	1SS119	V SYNC & DELAY
9	1SS119	2FH MULTI
11	MC932	PROT

BJ board (SYNC PROCESSING & PULSE GEN)

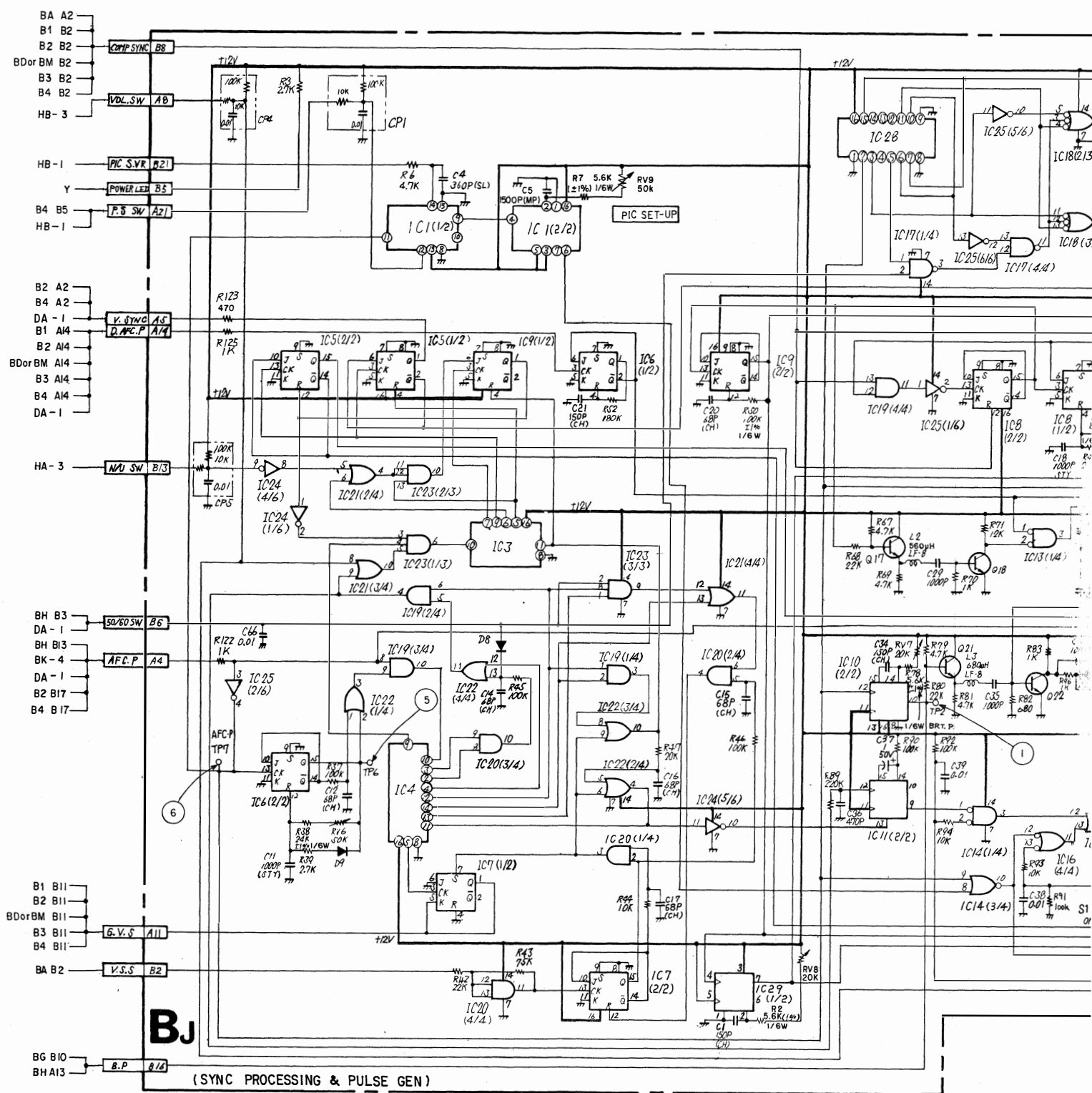

BJ BJ

BJ board (SYNC PROCESSING & PULSE GEN)

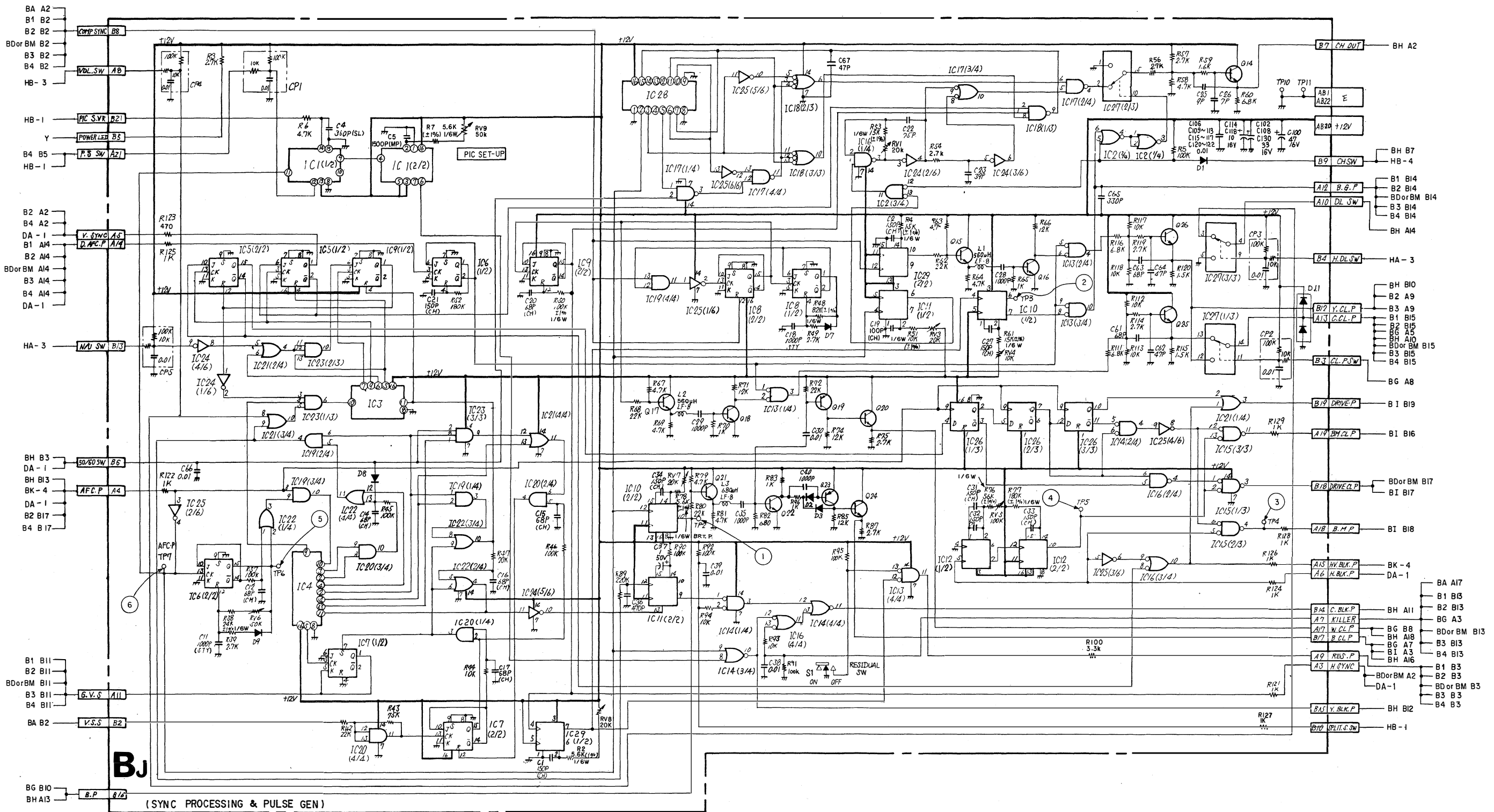

BK board (VIDEO OUT AMP)

IC												
Q	113	110	108	106	104	103	102	101	13	12		
	112	111	109	107	105	115	114					
	213	210	208	206	204	203	202	201				
	212	211	209	207	205	215	214					
	313	310	308	306	304	303	302	301				
D	111	112	107	104	101							
	109	113	108	106	102							
	211	212	207	204	201							
	209	213	208	206	202							
	311	312	307	304	301							
TP ADJ	TPI	TPI01 TPI02 TPI03	114	116	105	101						
			309	316	305	302						
				CV102 CV202 CV302		CV101 CV201 CV301						

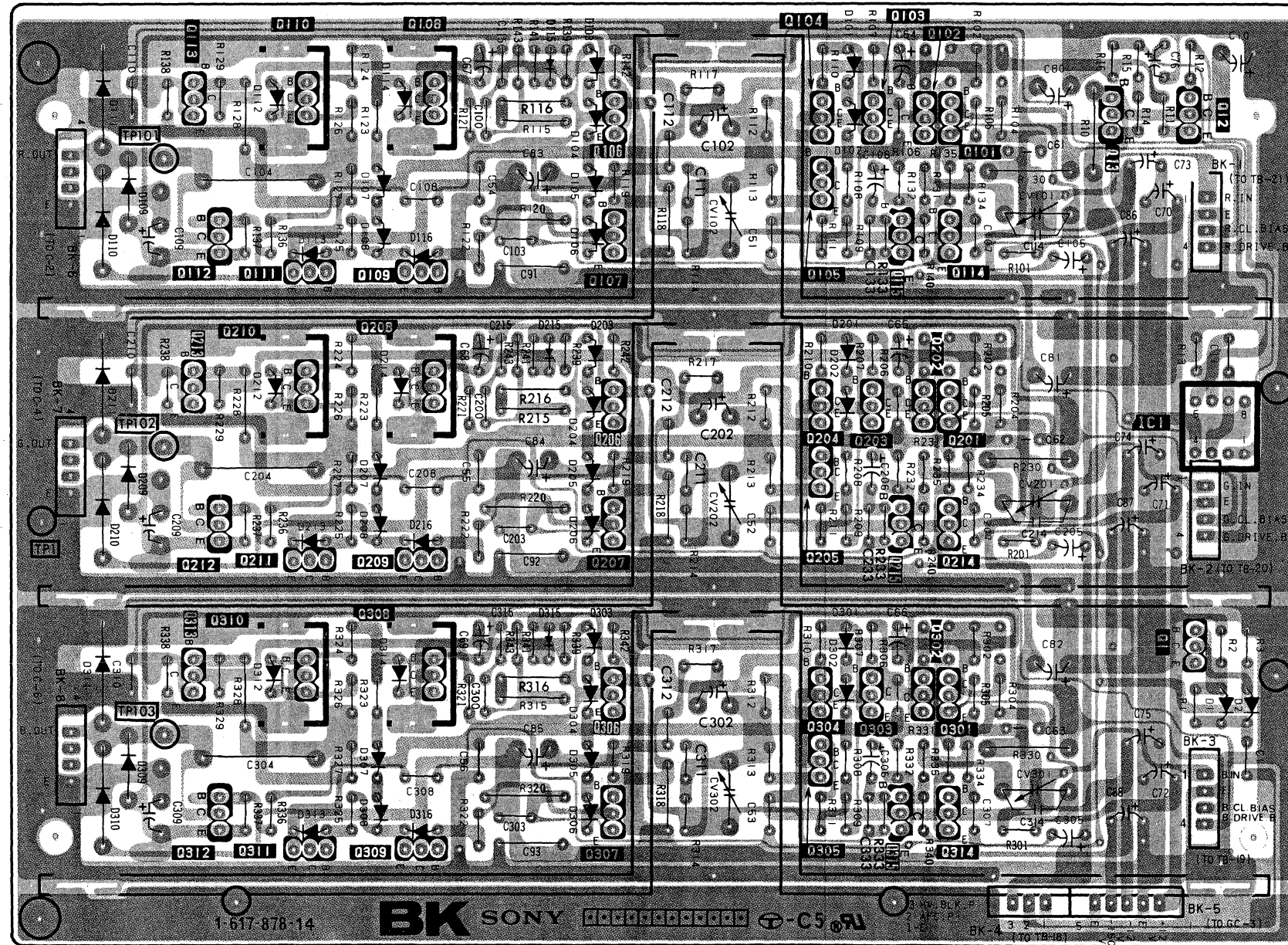

- : Conductor side pattern
- : Component side pattern

BK board (VIDEO OUT AMP)

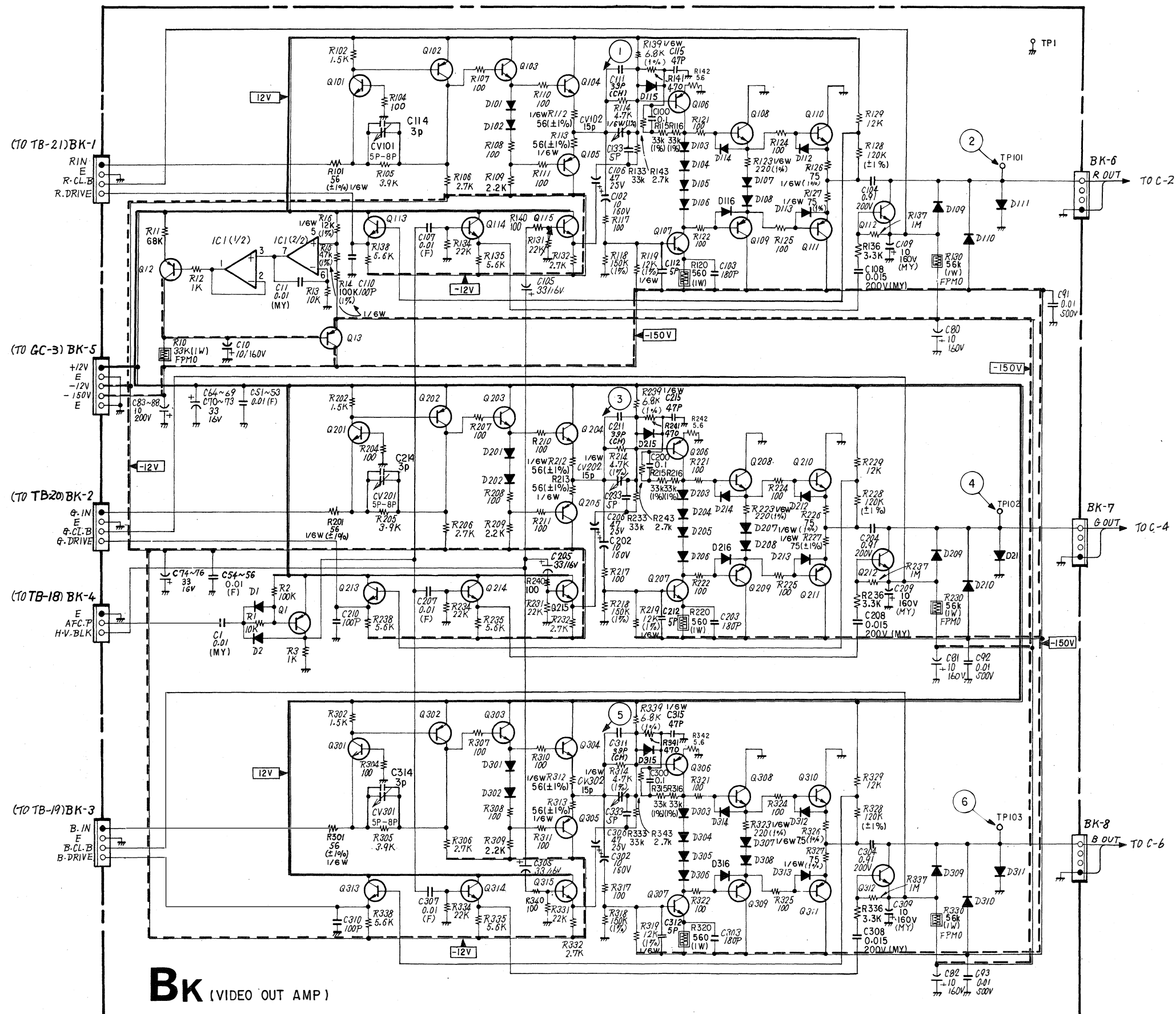

IC1	MB84027B	H. BLK. WIDTH
2	HD14011BP	H. DELAY. POSITION
3	TC4093BP	BUFFER
4	CX-158	H. OSC AFC
5	TL082CP	H. LIN. GEN.
6	TL082CP	H. LIN. GEN.
7	MC1496P	H. LIN. MOD.
8	LM2903DQ	1/2H, 1/2V. GEN.
9	TL082CP	H. BLK. PHASE
10	LM2903DQ	T & B. H. PHASE
11	TL082CP	T & B PIN. GEN.
12	MC1496P	T & B. PIN MOD.
13	uPD4066BC	50/60 SW.
14	uPD4066BC	DEF. LEVEL. SW
15	uPD4066BC	DEF. LEVEL. SW
16	uPD4066BC	DEF. LEVEL. SW
17	RC4558DQ	BUFFER
18	CX23025	50/60 SELECTOR
19	RC4558DQ	V. SAWTOOTH. GEN.
20	RC4558DQ	SIDE. PIN. GEN.
21	RC4558DQ	SIDE. PIN. GEN.
22	RC4558DQ	V. SAWTOOTH GEN.
23	RC4558DQ	BUFFER
24	uPC78M12H	+12V REG.
25	uPC79M12H	-15V REG.
	TL082CP	BUFFER
Q1	DTC144ES	H. OSC. SW
2	2SC2785	H. LIN. GEN
3	2SC2785	H. LIN. GEN
4	2SC2785	1/2H. P. GEN.
5	2SC2785	H. BLK. GEN.
6	2SC2785	H. BLK. GEN.
7	2SC2785	T & B PIN. PHASE

8	2SC2785	T & B PIN. GEN.
9	2SC2785	T & B PIN. GEN.
10	2SC3068	T & B PIN. MOD.
12	DTC144ES	50/60 SW
13	DTC144ES	SCAN. SW
14	DTC144ES	SCAN. SW
15	DTC144ES	SCAN. SW
16	DTC144ES	SCAN. SW
17	DTC144ES	50/60 SW
18	2SC2785	BUFFER
19	2SC2785	V. SAW. GEN
20	2SC2785	V. SAW. CLIP
21	2SC2785	SIDE PIN GEN
22	2SC2785	SIDE PIN GEN
23	2SC2785	SIDE PIN GEN
24	2SC2785	V. SAW GEN.
D1	1SS148	H. DELAY SW
2	1SS148	H. DELAY SW
3	RD6.8EB	CLIPPER
4	RD6.8EB	CLIPPER
5	RD12E-B	50/60 SW
6	RD12E-B	SCAN SW
7	1SS148	SCAN SW
8	1SS148	SCAN SW
9	RD7.5E-B	+7.5V REG.
10	RD7.5E-B	-7.5V REG.
11	RD15E-B	50/60 SW.
12	RD5.6E-B	V. SAW. CLIP
13	1SS148	V. SAW. CLIP
14	1SS148	V. SAW. CLIP
15	1SS148	AFC.CLIP
18	1SS148	PROT
19	1SS148	

DA board (DEFLECTION WAVEFORM)

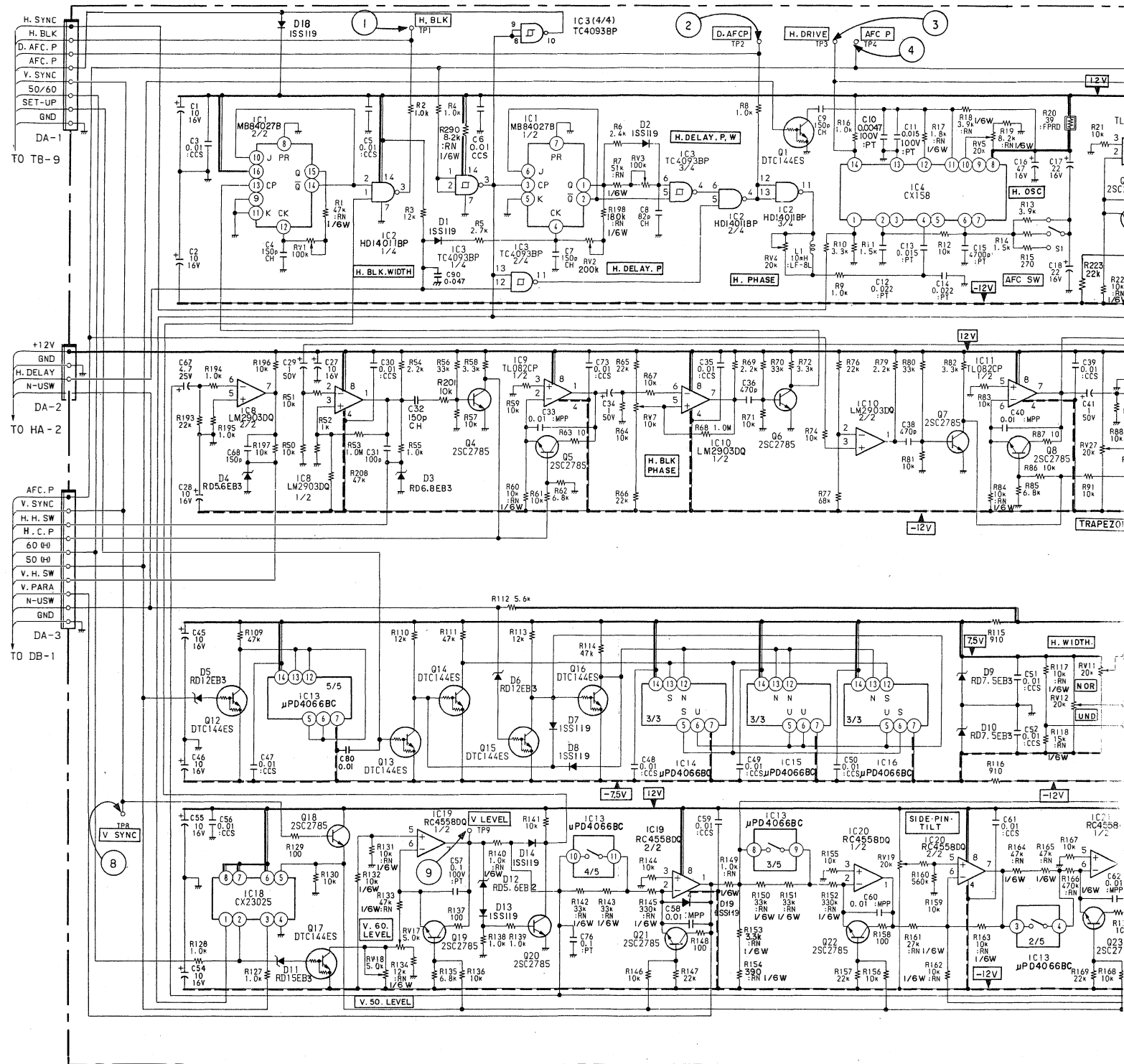

5. DIAGRAMS

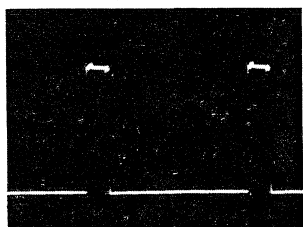

1 12Vp-p (H)

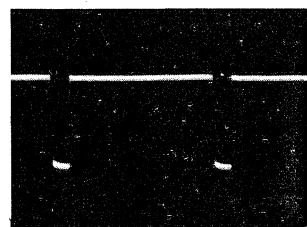

4 9Vp-p (H)

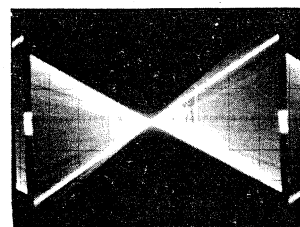

7 0.5Vp-p (V)

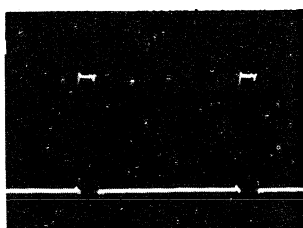

2 12Vp-p (H)

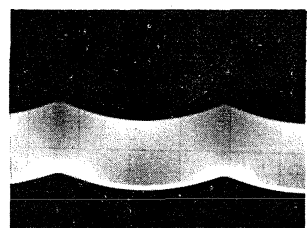

5 3.5Vp-p (H)

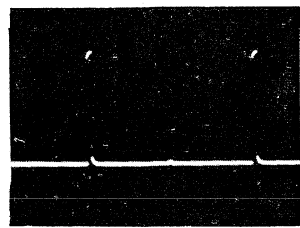

8 12Vp-p (V)

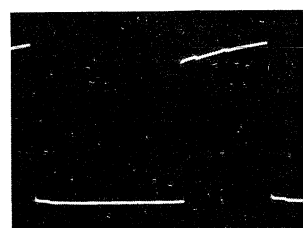

3 9Vp-p (H)

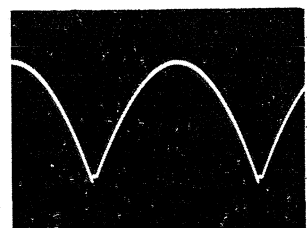

6 1.2Vp-p (V)



9 12Vp-p (V)



10 6Vp-p (V)

DA board (DEFLECTION WAVEFORM)

IC	Q	D	TP	ADJ
7	18	4		
8 18 17	17	11		
		3	TP6	RV18
		13		RV12 RV11
		14	TP8	RV6 RV17
5, 6, 9	4, 20	14	TP5	
		12		
		19	TP9	RV24 RV23
19	2 3	19	TP3	RV7
25	15			RV5
				RV19
10				RV16 RV15
4	20	1		
		6		
		7		
		5		RV4
		8		
24	12			RV14 RV13
2	23		TP2	RV28
			TP1	
11, 26		9		
3	21	18	TP4	
		10	TP7	RV27 RV21
		8		RV1 RV20
		6		
		7	TP10	
1 12 22	13, 14 15, 16	7		
		2	TP11	
				RV2 RV10 RV26
				RV3 RV22 RV25
		10		

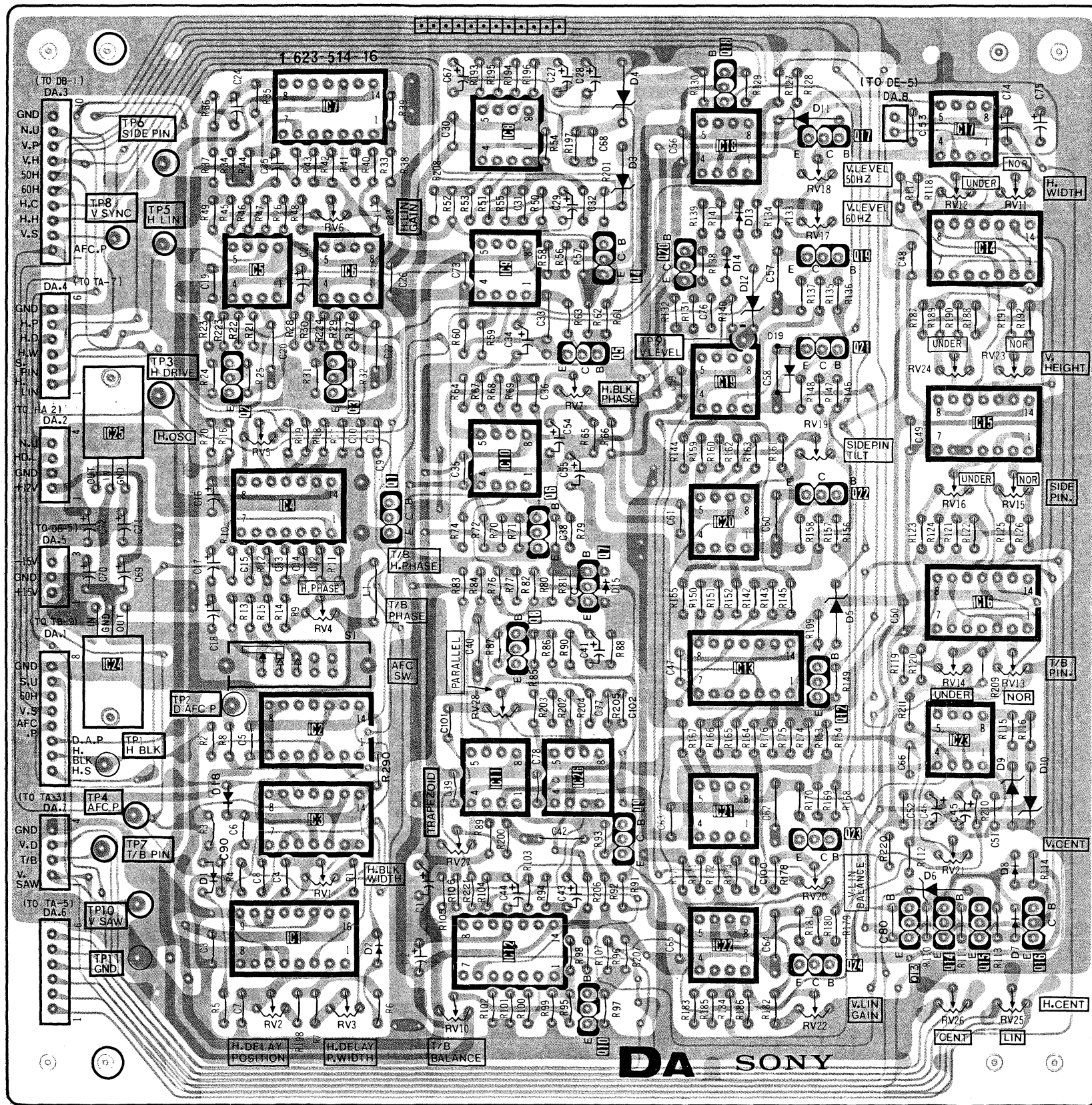

Conductor side pattern
 Component side pattern

DB board (CONVERGENCE WAVEFORM)

IC	Q	D	TP	ADJ
			11	
16	38 33 34			RV26 RV11 RV21 RV6 RV16 RV1
10 15	40 41	4 3	9	RV27 RV12 RV22 RV7 RV17 RV2
8	35 36 37		10	
		5	1	RV28 RV13 RV23 RV8 RV18 RV3
9 3				RV29 RV14 RV24 RV9 RV19 RV4
	10,12 11		3 4	RV30 RV15 RV25 RV10 RV20 RV5
4	15 17 14,16 13 19 18	8		
	45 46 42 20			RV33 RV32 RV31
5 6	21 25 4 5 2	2		
1	23 27 22 24,26 28		6 7	
	7 29 3,44			
2 7 11	43 31 8 9,30,32		12	
		7	8	
		6	5	
13,14				

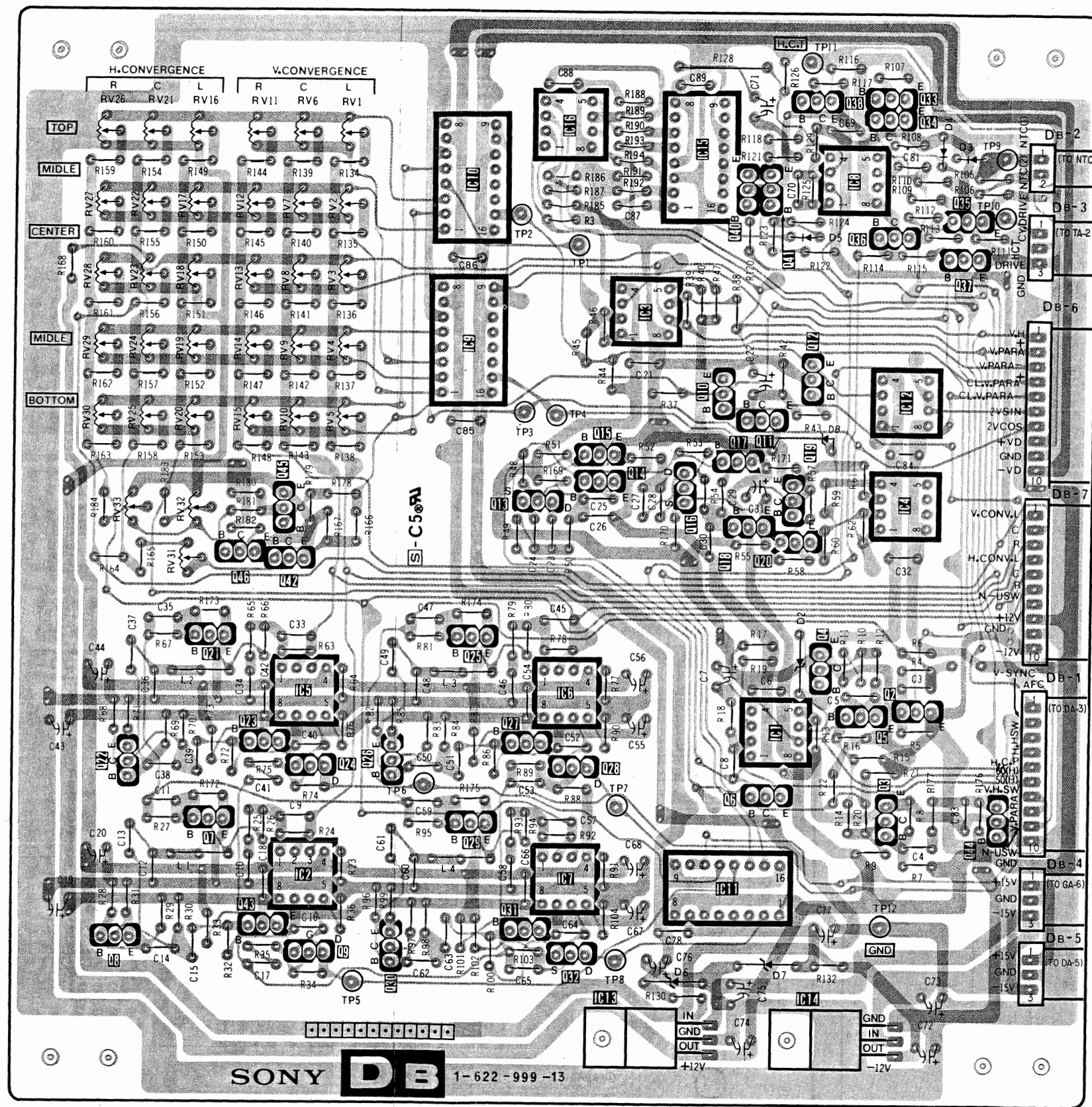

DB board (CONVERGENCE WAVEFORM)

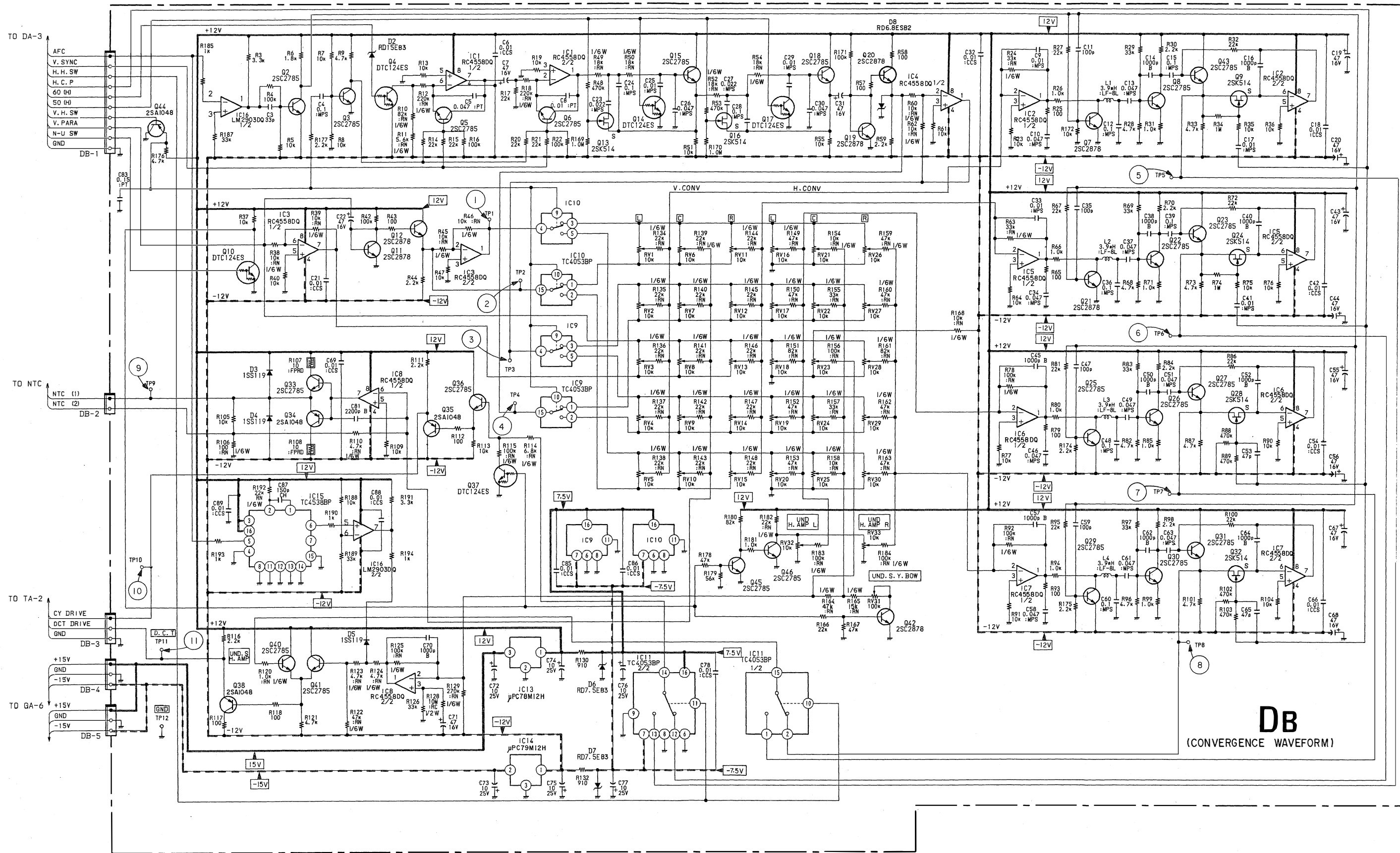

DB
(CONVERGENCE WAVEFORM)

DB BOARD

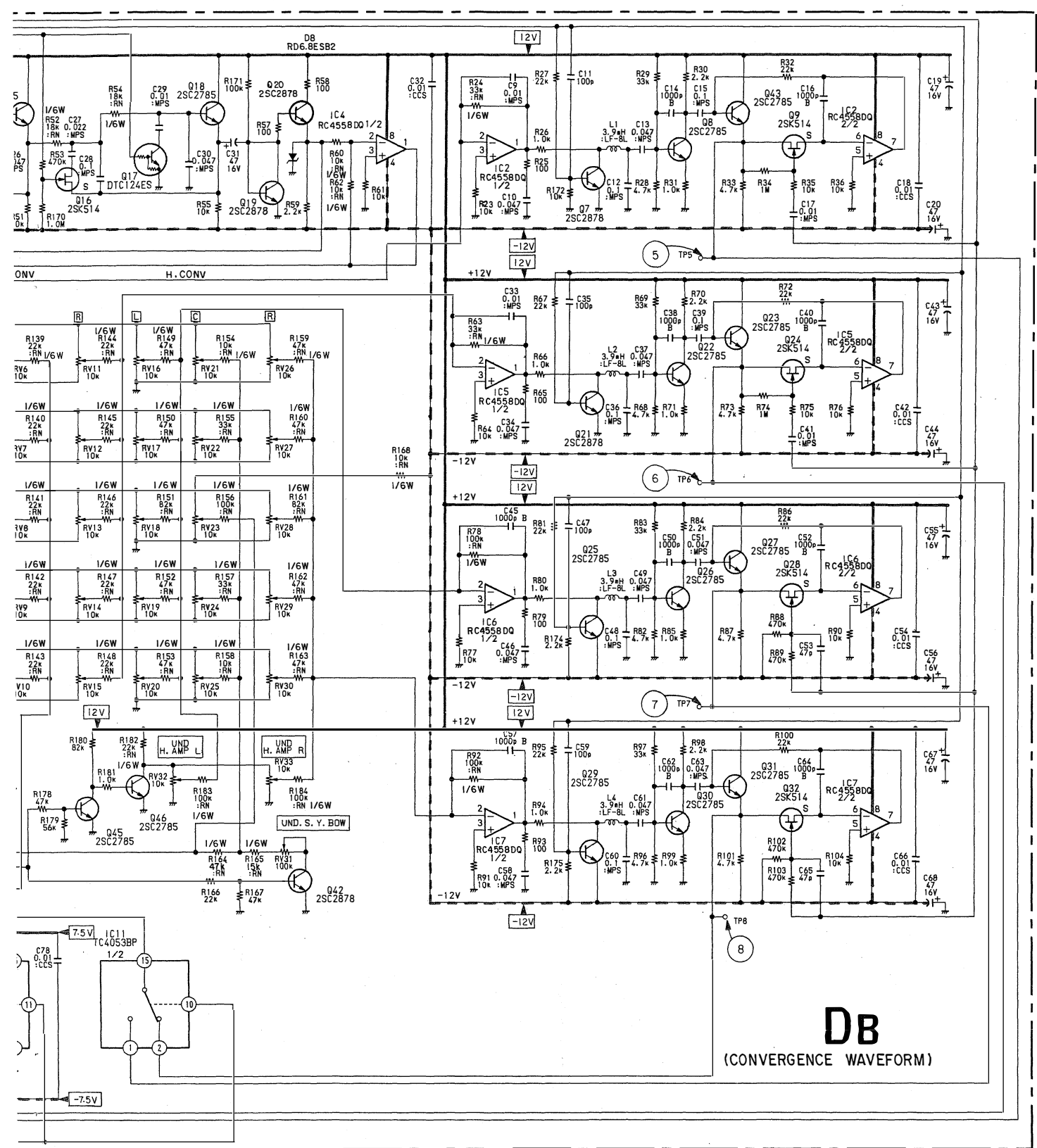

IC 1	RC4558DQ	2XV GEN
2	RC4558DQ	AMP & CLAMP
3	RC4558DQ	INVERTER
4	RC4558DQ	INVERTER
5	RC4558DQ	AMP & CLAMP
6	RC4558DQ	AMP & CLAMP
7	RC4558DQ	AMP & CLAMP
8	RC4558DQ	AMP
9	TC4053BP	
10	TC4053BP	
11	TC4053BPHB	1/2HV. SW
13	uPC78M12H	+12V REG.
14	uPC79M12H	-12V REG.
15	HD14538BP	H.CONV CLAMP
16	LM2903DQ	INVERTER
Q 2	2SC2785	H. SW
3	2SC2785	2XV. PULSE GEN
4	DTC124ES	50/60 SW
5	2SC2785	2XV SW
6	2SC2785	2XV SW
7	2SC2878	H. SW
8	2SC2785	AMP
9	2SK514	H. CLAMP
10	DTC124ES	N/U SW
11	2SC2878	CLAMP
12	2SC2878	BUFFER
13	2SK514	50/60 SW
14	DTC124ES	50/60 SW
15	2SC2785	50/60 SW
16	2SK514	50/60 SW
17	DTC124ES	50/60 SW
18	2SC2785	BUFFER
19	2SC2878	CLAMP
Q 20	2SC2878	BUFFER
21	2SC2878	H. SW
22	2SC2785	AMP
23	2SC2785	H. CLAMP
24	2SK514	H. CLAMP
25	2SC2785	H. SW
26	2SC2785	AMP
27	2SC2785	H. CLAMP
28	2SK514	H. CLAMP
29	2SC2785	H. SW
30	2SC2785	AMP
31	2SC2785	H. CLAMP
32	2SK514	H. CLAMP
33	2SC2785	N.T.C AMP
34	2SA1175	N.T.C AMP
35	2SA1175	BUFFER
36	2SC2785	BUFFER
37	DTC124ES	N/U SW
38	2SA1175	BUFFER
40	2SC2785	ADDER
41	2SC2785	ADDER
42	2SC2878	N/U SW
44	2SA1175	BUFFER
45	2SC2785	UND.H.AMP
46	2SC2785	UND.H.AMP
D 2	RD15E-B3TN	LEVEL SHIFT
3	1SS148	PROTECTOR
4	1SS148	PROTECTOR
5	1SS148	DC STOPPER
6	RD7.5E-B3TN	+7.5V REG.
7	RD7.5E-B3TN	-7.5V REG.
8	RD6.8ESB2	LIMITTER

Q 20	2SC2878	BUFFER
21	2SC2878	H. SW
22	2SC2785	AMP
23	2SC2785	H. CLAMP
24	2SK514	H. CLAMP
25	2SC2785	H. SW
26	2SC2785	AMP
27	2SC2785	H. CLAMP
28	2SK514	H. CLAMP
29	2SC2785	H. SW
30	2SC2785	AMP
31	2SC2785	H. CLAMP
32	2SK514	H. CLAMP
33	2SC2785	N.T.C AMP
34	2SA1175	N.T.C AMP
35	2SA1175	BUFFER
36	2SC2785	BUFFER
37	DTC124ES	N/U SW
38	2SA1175	BUFFER
40	2SC2785	ADDER
41	2SC2785	ADDER
42	2SC2878	N/U SW
44	2SA1175	BUFFER
45	2SC2785	UND.H.AMP
46	2SC2785	UND.H.AMP
D 2	RD15E-B3TN	LEVEL SHIFT
3	1SS148	PROTECTOR
4	1SS148	PROTECTOR
5	1SS148	DC STOPPER
6	RD7.5E-B3TN	+7.5V REG.
7	RD7.5E-B3TN	-7.5V REG.
8	RD6.8ESB2	LIMITTER

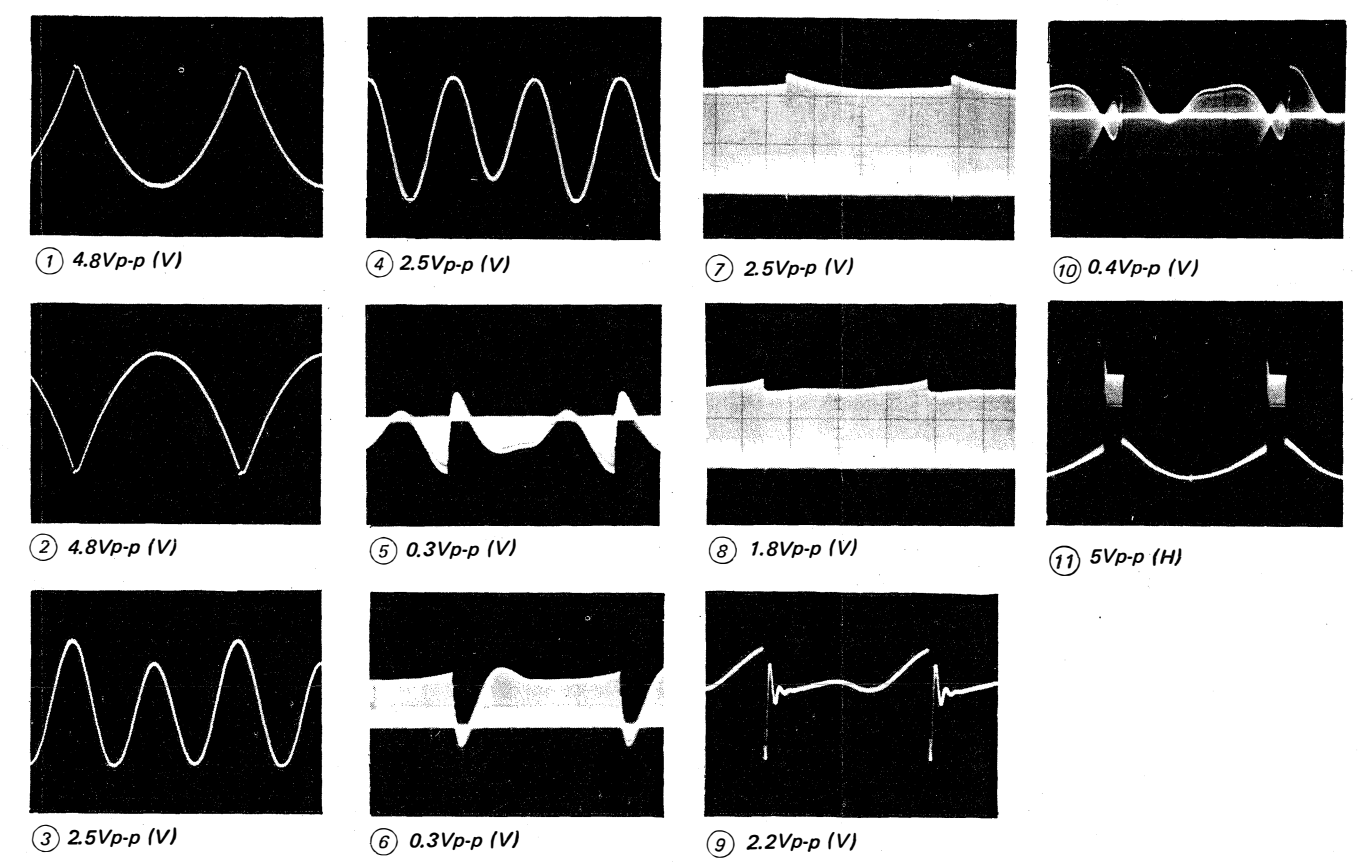

5. DIAGRAMS

EA board (H OUT)

IC	1											2										
Q	10	11		4				5	3			16			14							
D	8		9		7		3		4			16			12	11		14	13		10	
TP	TP 3														TP 1						TP 2	
	TP 4																					

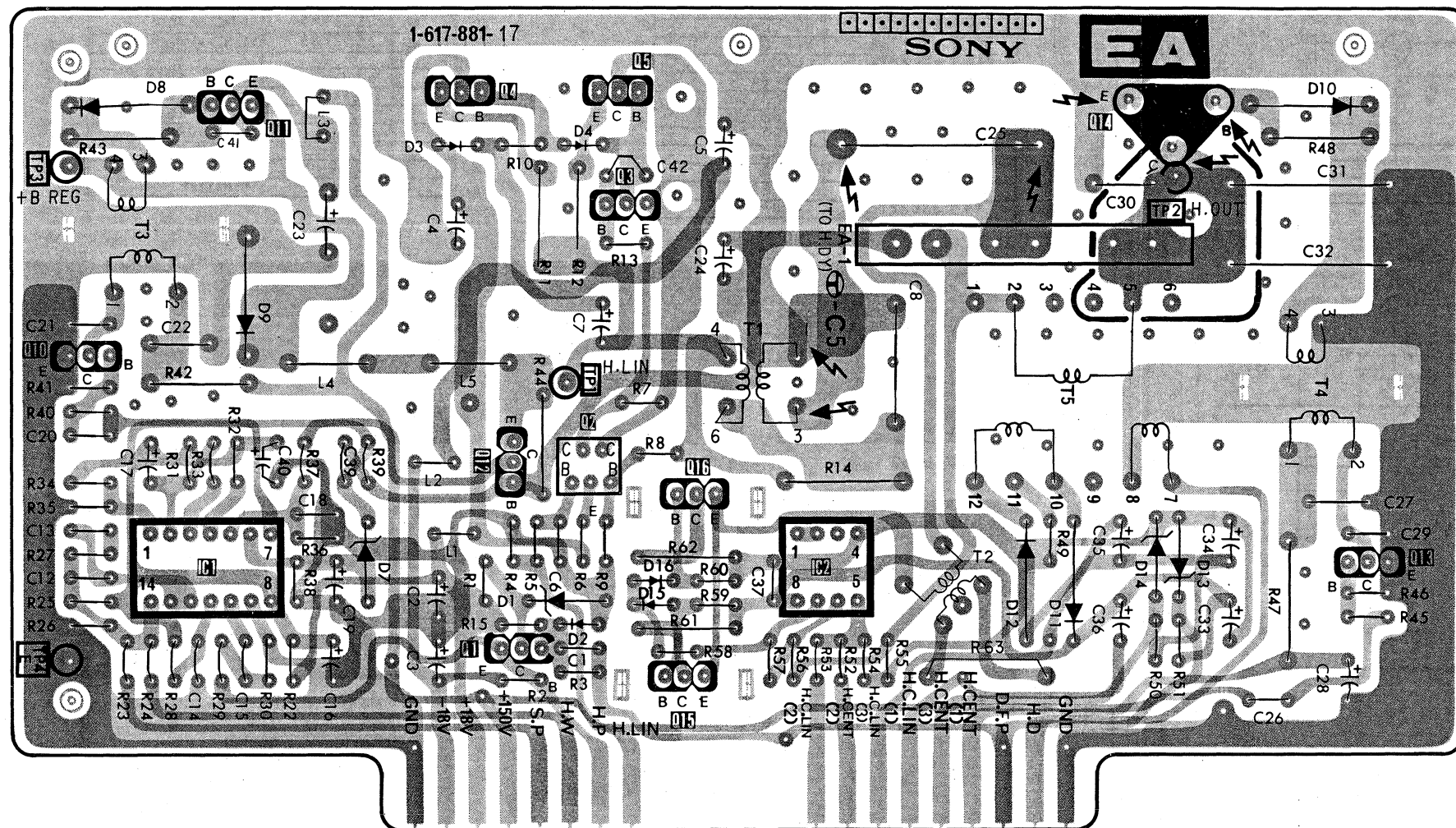

5. DIAGRAMS

EB board (V OUT)

Q			5		6																	
D			7	8	3	4																
TP				5		4	1	2	3													
			6																			

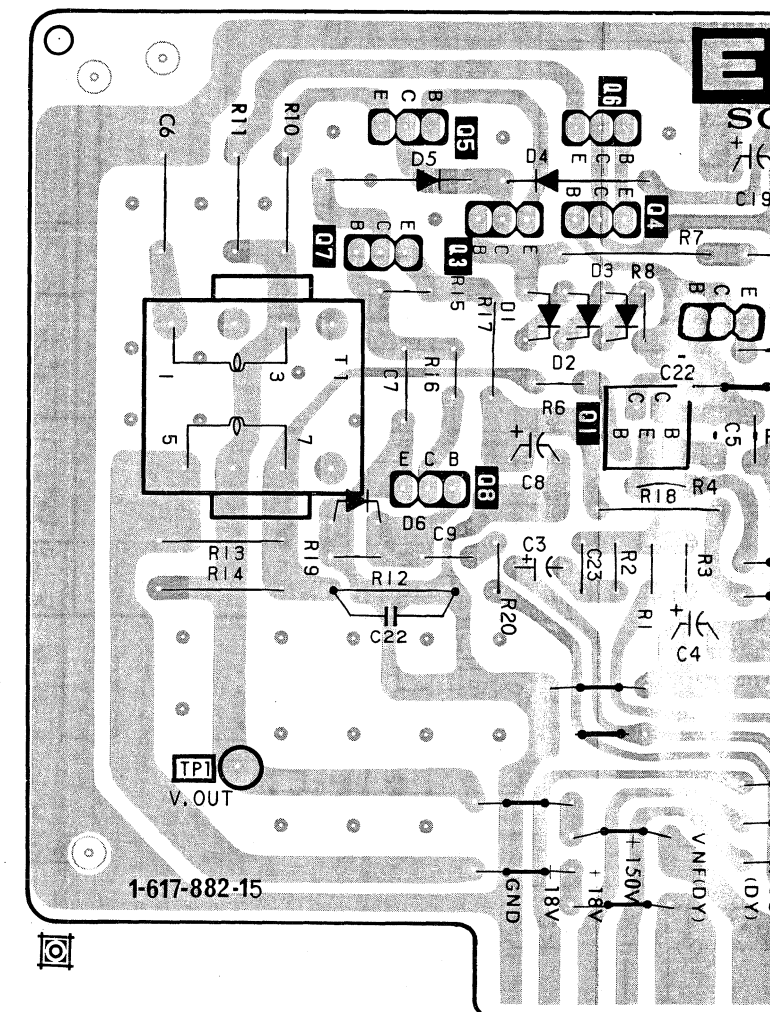

EA, EB EA, EB

EB board (V OUT)

14	13
14 13	10
TP 2	

Q	7	5	3	6	4	2	18	19	12	13	11	9
D	6	5	4	1	2	3	9	10	7	8		
TP	TPI			TP5			TP4		TP3		TP2	

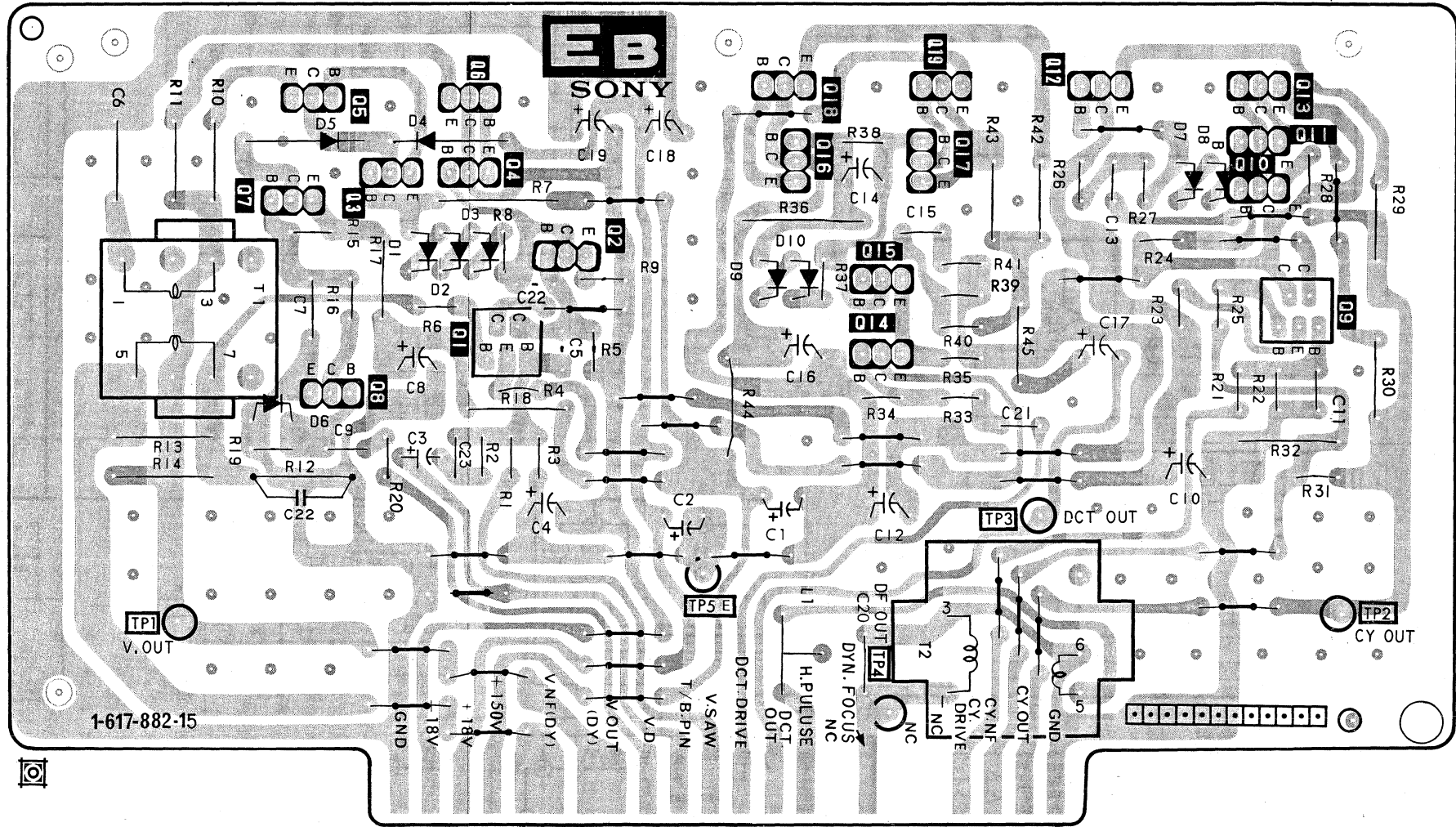
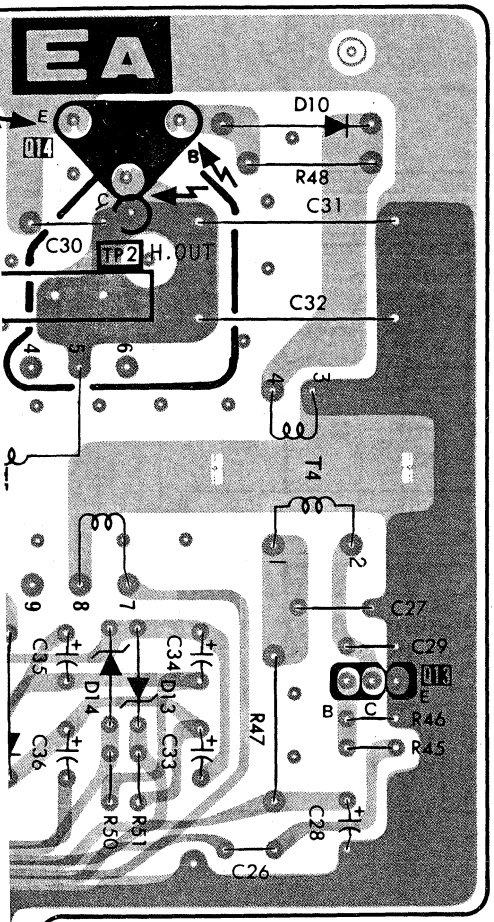

• : Conductor side pattern
 • : Component side pattern

EA board (H OUT)
EB board (V OUT)

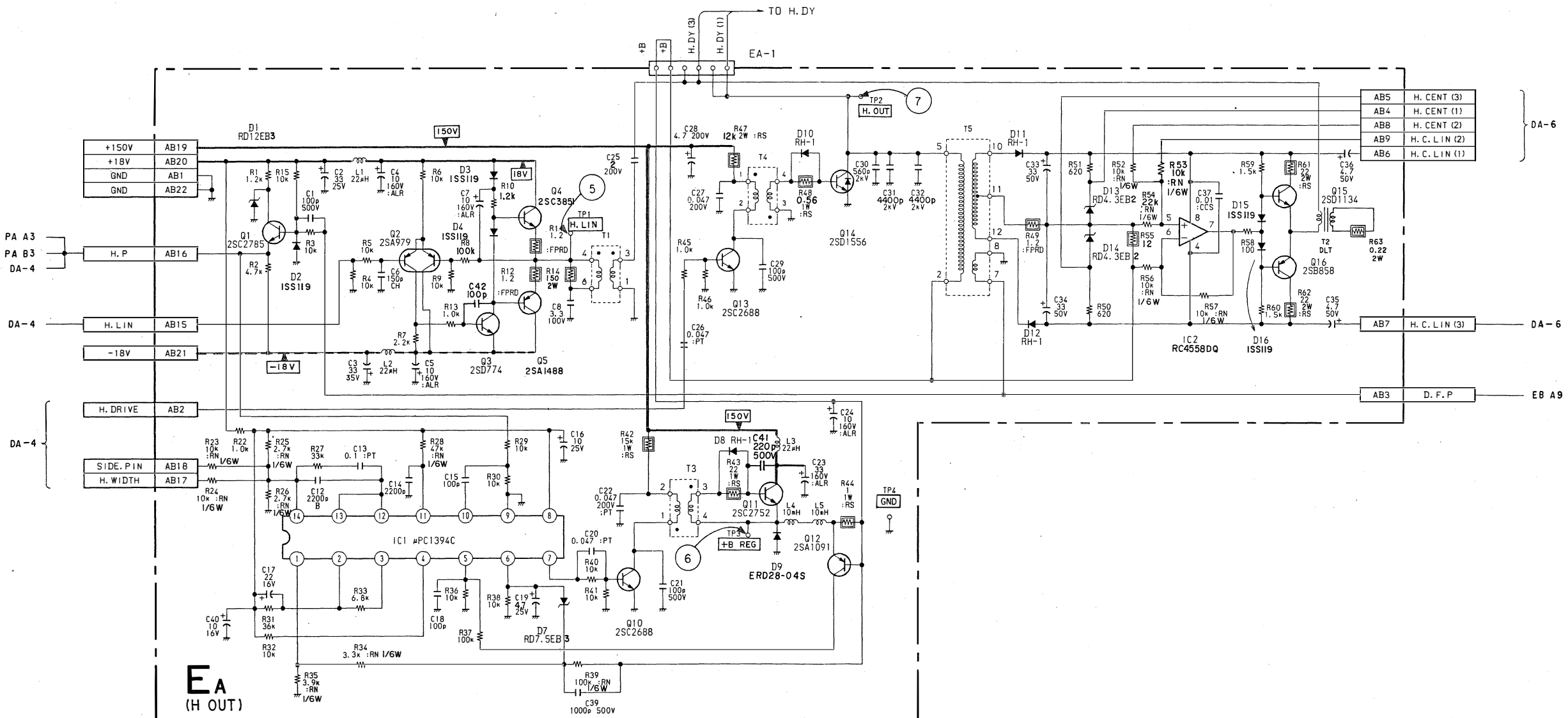
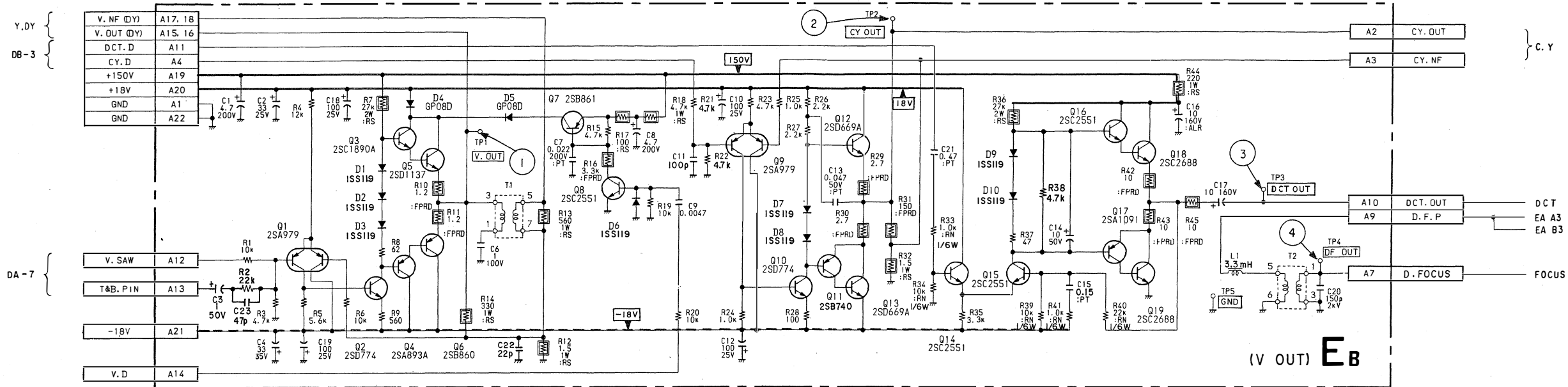

EA BOARD

EB BOARD

IC1	uPC1394C	P.W.M CONTROL
2	RC4558DQ	H.CENT
Q1	2SC2785	H.PULSE BUFFER
2	2SA979	H.LIN AMP
3	2SD774	H.LIN AMP
4	2SC1173	H.LIN AMP OUT
5	2SA473	H.LIN AMP OUT
10	2SC2688	P.W.M DRIVE
11	2SC2752	P.W.M OUT
12	2SA1091	O.C.P
13	2SC2688	H.DRIVE
14	2SD1556	H.OUT
15	2SD1134	H.CENT
16	2SB858	H.CENT
D1	RD12E-B	CLIPPER
2	1SS148	PROTECTOR
3	1SS148	BIAS
4	1SS148	BIAS
7	RD7.5E-B	PROTECTOR
8	RH-1	P.W.M DRIVE
9	ERD28-04S	P.W.M SW
10	RH-1	H.DRIVE
11	RH-1	H.P.RECT.
12	RH-1	H.P.RECT.
13	RD4.3E-B	+4.3V REG
14	RD4.3E-B	-4.3V REG
15	1SS148	BIAS
16	1SS148	BIAS
Q1	2SA979	V.AMP
2	2SD774	V.AMP
3	2SC1890A	V.AMP
4	2SA893A	V.AMP
5	2SD1137	V.AMP OUT
6	2SB860	V.AMP OUT
7	2SB861	V.RETRACE SW
8	2SC25510	V.RETRACE SW
9	2SA979	CY.AMP
10	2SD774	CY.AMP
11	2SB740	CY.AMP
12	2SD669A	CY.AMP OUT
13	2SD669A	CY.AMP OUT
14	2SC25510	D.C.T AMP
15	2SC25510	D.C.T AMP
16	2SC25510	D.C.T AMP
17	2SA1091	D.C.T AMP
18	2SC2688	D.C.T AMP OUT
19	2SC2688	D.C.T AMP OUT
D1	1SS148	BIAS
2	1SS148	BIAS
3	1SS148	BIAS
4	GP08D	DC.STOPPER
5	GP08D	DC.STOPPER
6	1SS148	PROTECTOR
7	1SS148	BIAS
8	1SS148	BIAS
9	1SS148	BIAS
10	1SS148	BIAS

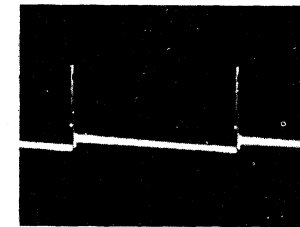
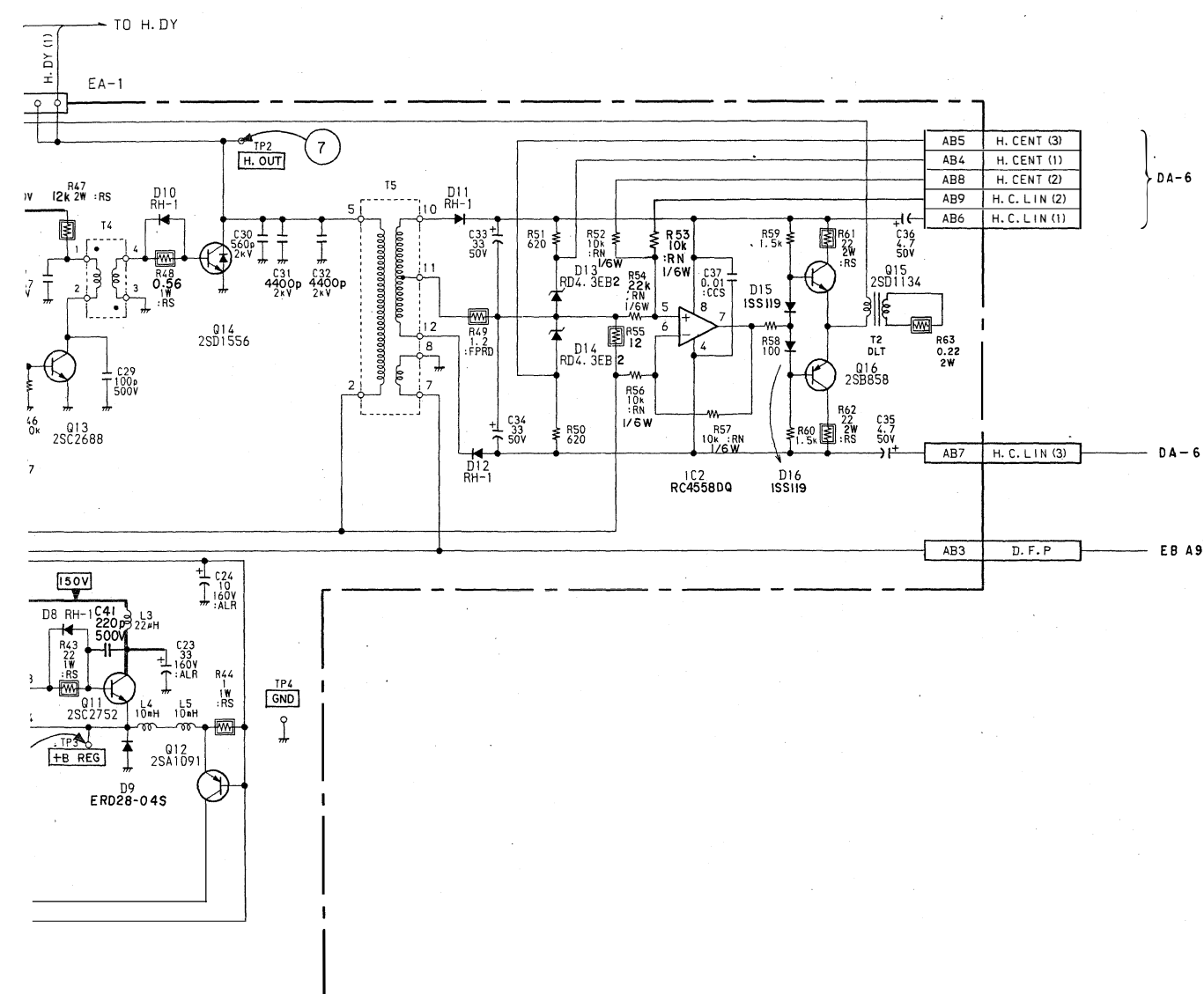
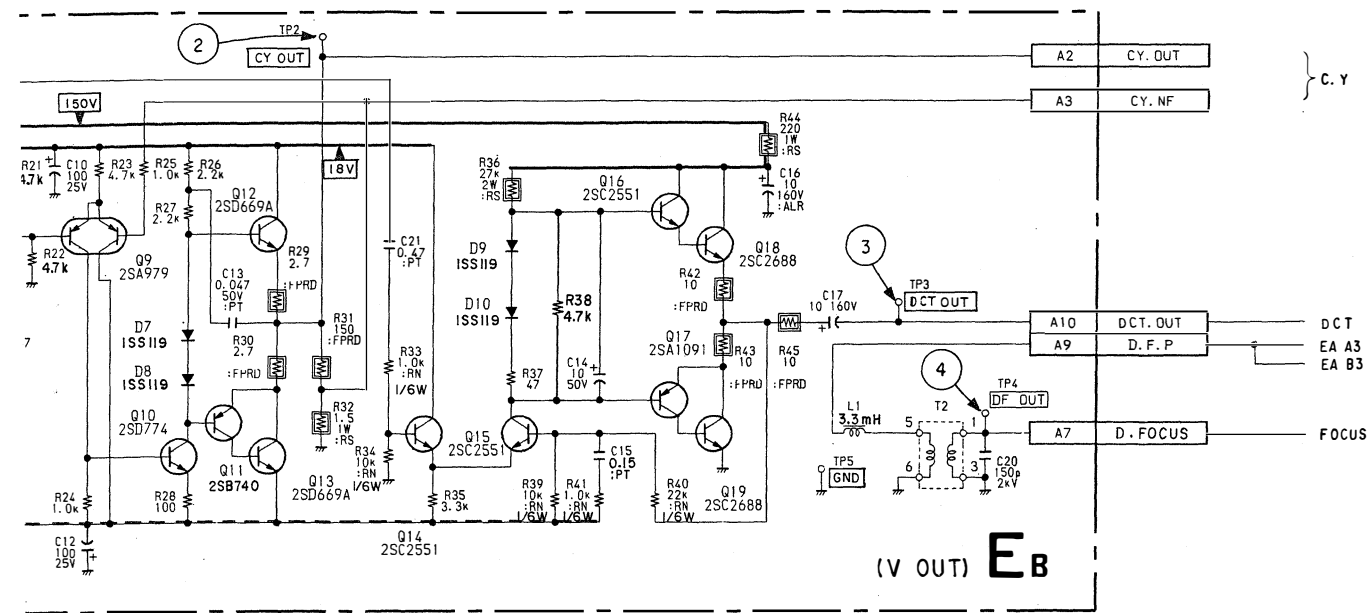

① 80Vp-p (V)

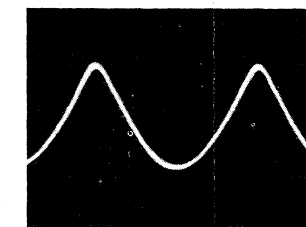

④ 210Vp-p (H)

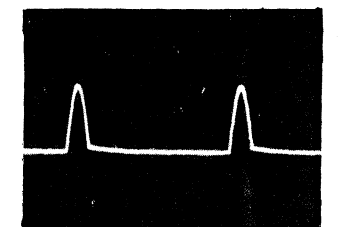

⑦ 650Vp-p (H)

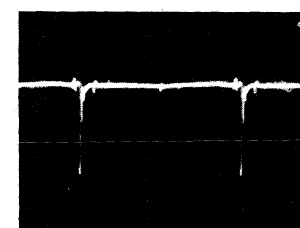

② 20Vp-p (H)

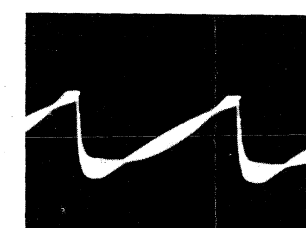

⑤ 34Vp-p (H)

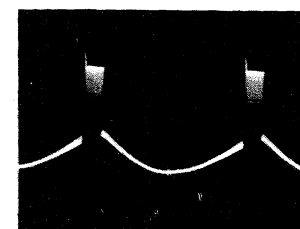

③ 100Vp-p (H)

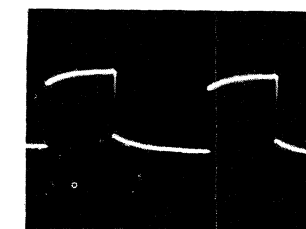

⑥ 160Vp-p (H)

GB board (OVER VOLTAGE PROTECTOR)

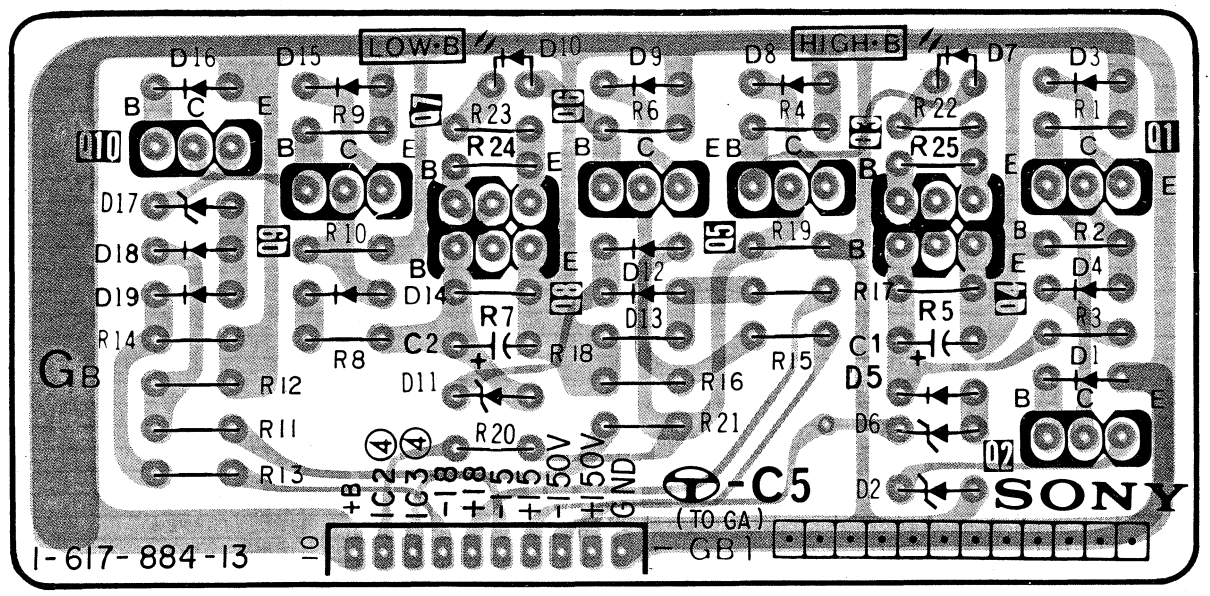

GA board (AC RECT, DC REG)

IC	Q	D	ADJ-TP
		23 25	TP2
	11		TP3
	12	18	
	10		
			RV1
		21	
	13	11	RV2 TP4 TP5
		5 6	
	2		
2	14		
3			TP1
	7	20 13	
	5	12	
9	6 3	15 10	
8		14 16 17	
	4	7	
		31,32	
		29 30 27	
		26	
		22	
		28	
		3 4 9 8	

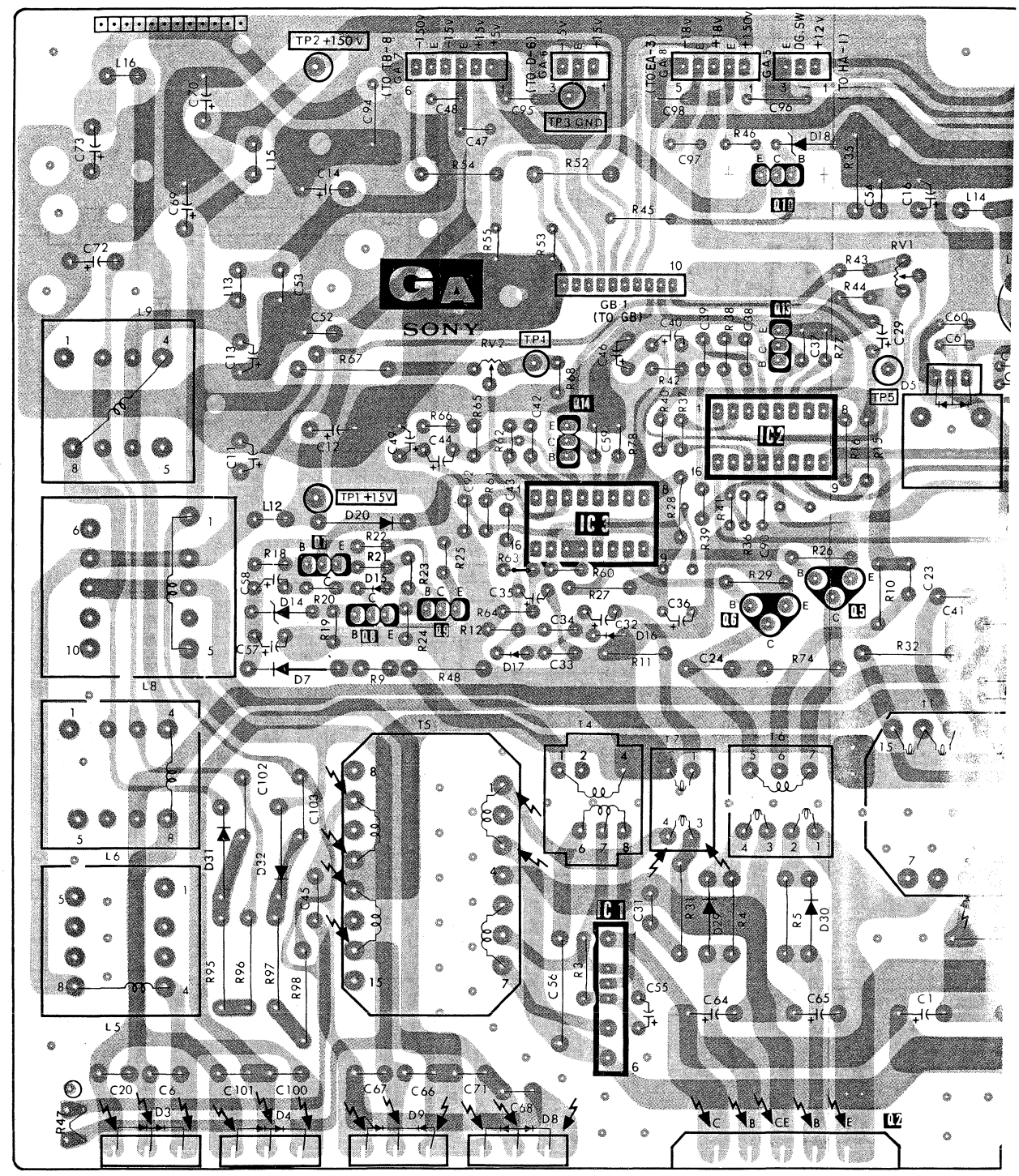

5. DIAGRAMS

I (AC RECT, DC REG)

Q	D	ADJ-TP
	23 25	TP2
11		TP3
12	18	
10		RV1
21		
13	11	RV2 TP4
5	6	TP5
2		
14		TP1
20	13	
7	12	
5	15	
9	10	
6	14	
3	16	
8	17	
4	7	
	31,32	
	29 30 27	
	26	
	22	
	28	
3	4	
2	9	
1	8	

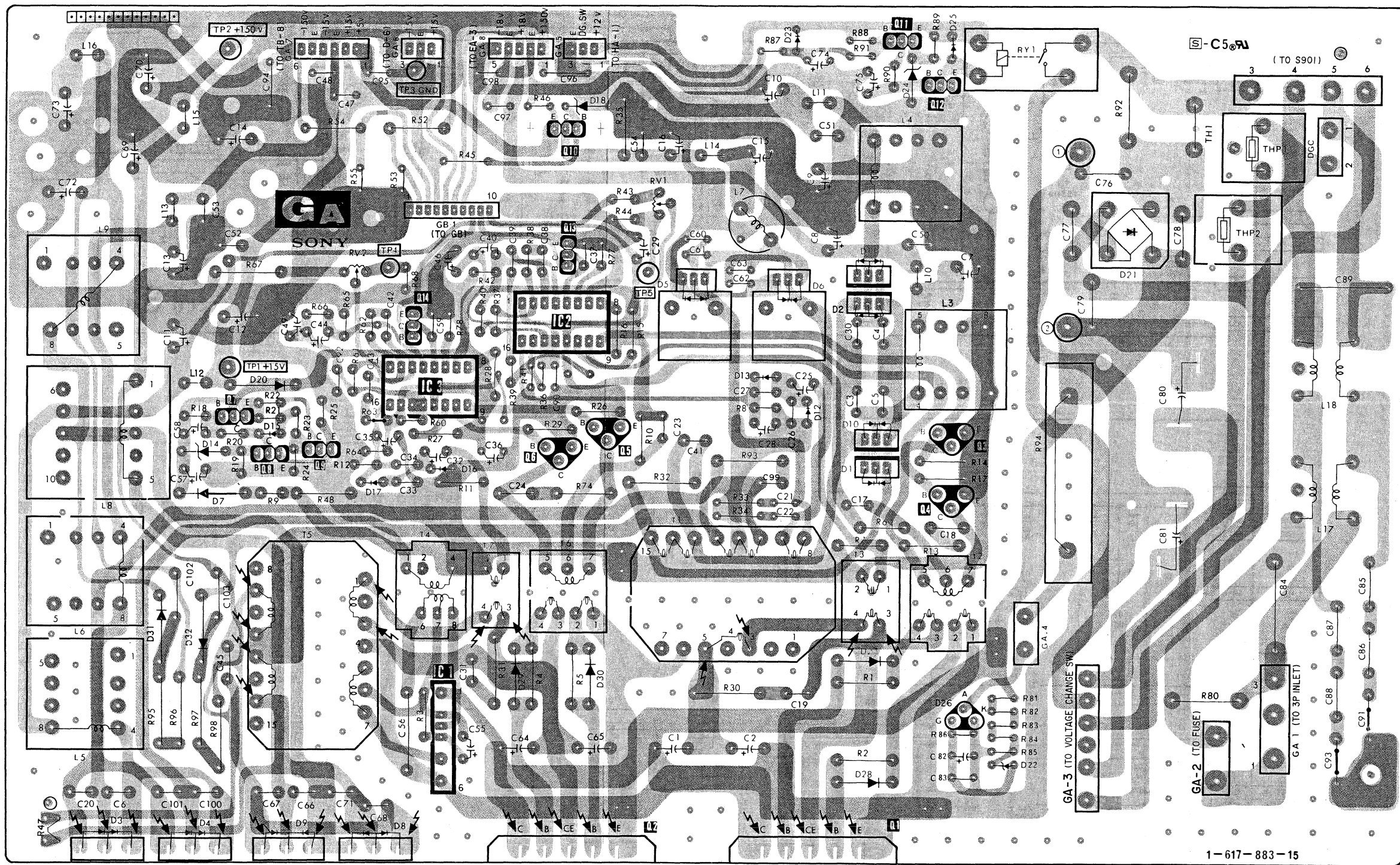

: Conductor side pattern
 : Component side pattern

GA, GB GA, GB

GA board (AC RECT, DC REG)
GB board (OVER VOLTAGE PROTECTOR)

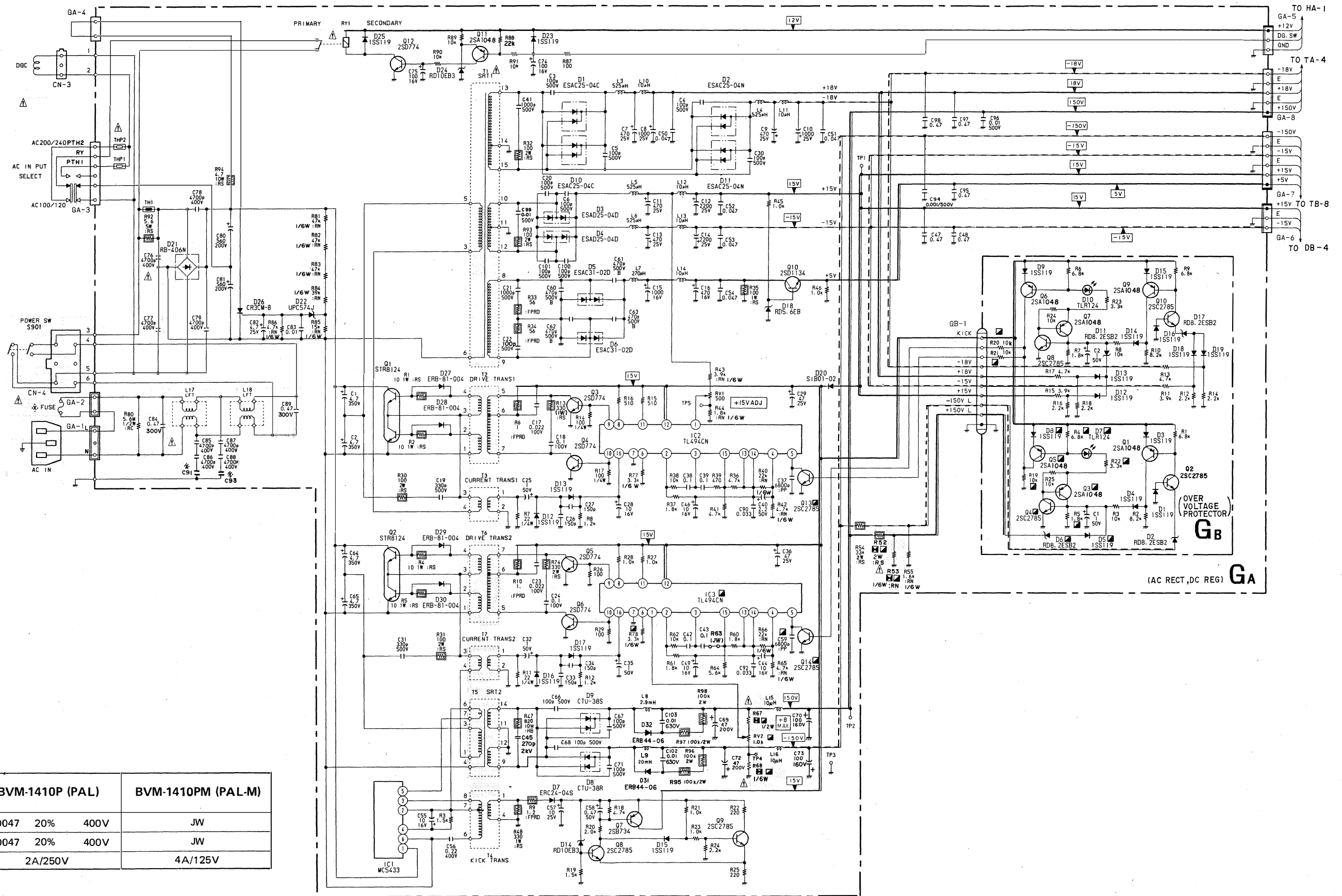

NOTE

Model Ref	BVM-1410P (PAL)	BVM-1410PM (PAL-M)
C91	0.0047 20% 400V	JW
C93	0.0047 20% 400V	JW
FUSE	2A/250V	4A/125V

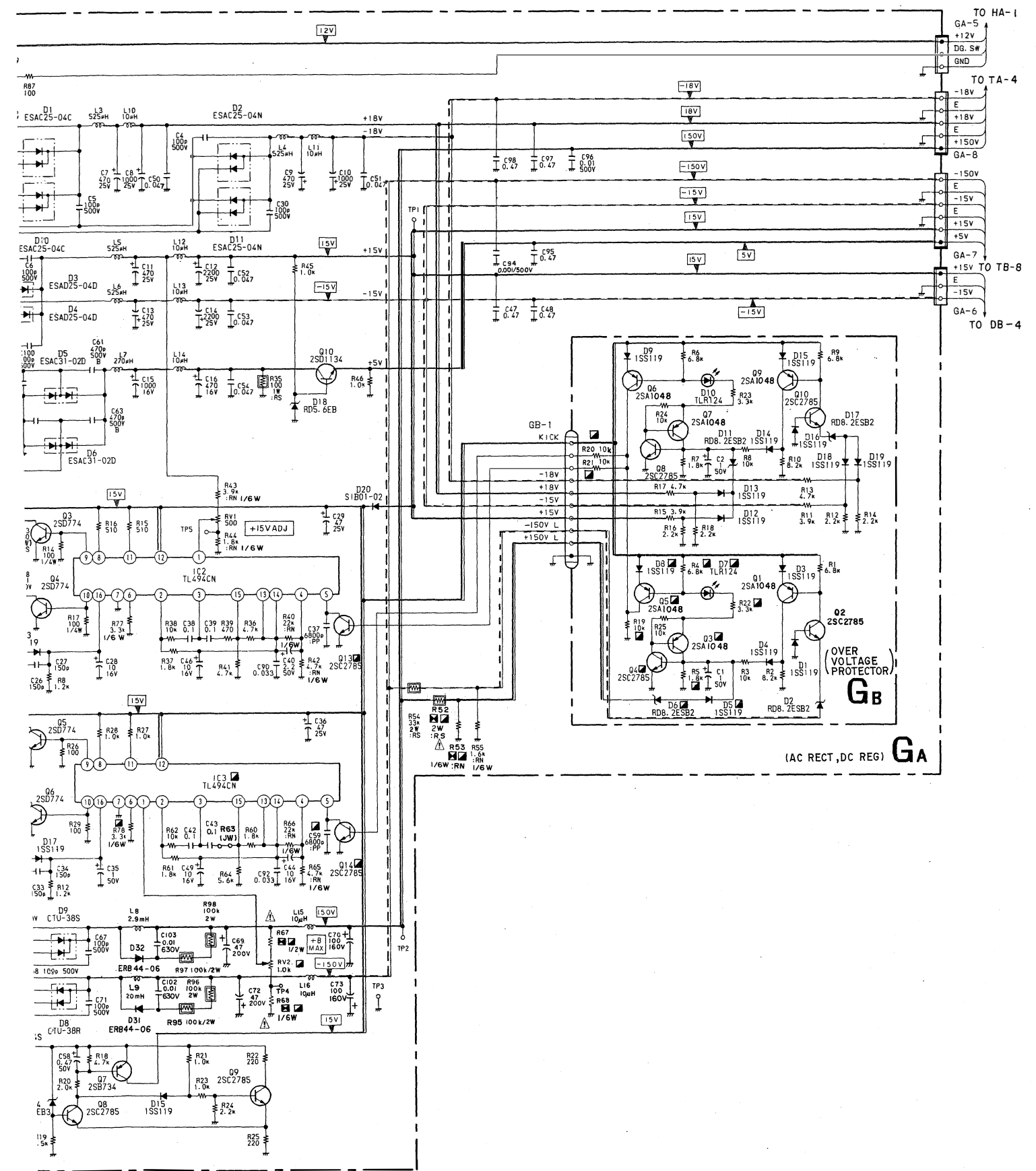

GA BOARD

IC1	MC5433	STARTER
2	TL494CN	DC REG
3	TL494CN	DC REG
Q1	STR8124	DC-DC CONV.
2	STR8124	DC-DC CONV.
3	2SD774	CONV. DRIVE
4	2SD774	CONV. DRIVE
5	2SD774	CONV. DRIVE
6	2SD774	CONV. DRIVE
7	2SB734	SOFT. START
8	2SC2785	SOFT. START
9	2SC2785	SOFT. START
10	2SD1134	+5V REG.
11	2SA1048	D.G. CONTROL
12	2SD774	D.G. CONTROL
13	2SC2785	O.V.P SW
14	2SC2785	O.V.P SW
D1	ESAC25-04C	+18V RECT
2	ESAC25-04N	-18V RECT
3	ESAD25-04D	+15V RECT
4	ESAD25-04D	-15V RECT
5	ESAC31-02D	+5V RECT
6	ESAC31-02D	-5V RECT
7	ERC24-045	START. RECT
8	CTU-38R	-150V RECT
9	CTU-38S	+150V RECT
10	ESAC25-04C	+18V RECT
11	ESAC25-04N	-18V RECT
12	1SS119	O.C.P RECT
13	1SS119	O.C.P RECT
14	RD10EB3T	STARTER
15	1SS119	STARTER
16	1SS119	O.C.P RECT
17	1SS119	O.C.P RECT
18	RD5.6E-B2TN	+5V REG
20	SIB01-02	DC. STOPPER
21	RB406N	AC RECT
22	UPC574J	O.V.P
23	1SS119	DISCHARGE
24	RD10EB3T	+10V REG
25	1SS119	SW PROTECT
26	CR3CM-8	O.V.P
27	ERB81-004	CONV. DRIVE
28	ERB81-004	CONV. DRIVE
29	ERB81-004	CONV. DRIVE
30	ERB81-004	CONV. DRIVE
31	ERB44-06	
32	ERB44-06	

GB BOARD

Q1	2SA1048	O.V.P (-150V)
2	2SC2785	O.V.P (-150V)
3	2SA1048	O.V.P (+150V)
4	2SC2785	O.V.P (+150V)
5	2SA1048	O.V.P (+150V)
6	2SA1048	O.V.P (+15V)
7	2SA1048	O.V.P (+18V)
8	2SC2785	O.V.P (+15V)
9	2SA1048	O.V.P (-15V)
10	2SC2785	O.V.P (-18V)
D1	1SS119	PROTECTOR
2	RD8.2ES-T1B2	REFERENCE
3	1SS119	PROTECTOR
4	1SS119	MIX.
5	1SS119	MIX.
6	RD8.2ES-T1B2	REFERENCE
7	TLR124	O.V.P INDICATE
8	1SS119	PROTECTOR
9	1SS119	PROTECTOR
10	TLR124	O.V.P INDICATE
11	RD8.2ES-T1B2	REFERENCE
12	1SS119	MIX.
13	1SS119	MIX.
14	1SS119	MIX.
15	1SS119	PROTECTOR
16	1SS119	PROTECTOR
17	RD8.2ES-T1B2	REFERENCE
18	1SS119	MIX.
19	1SS119	MIX.

HA, HB, HC, HD, HG, HH, XB, Y HA, HB, HC, HD, HG, HH, XB, Y

HA board (LEFT CONTROL PANEL), HB board (SYSTEM SWITCH), HC board (INPUT SELECT), HD board (MANUAL CONTROL) Serial No. Up to 2,001,396 (BVM-1410P), Serial No. Up to 2,000,020 (BVM-1410PM), HG board (CONTROL PANEL 2) Serial No. 2,001,397 and Higher (BVM-1410P) Serial No. 2,000,021 and Higher (BVM-1410PM), HH board (CONTROL PANEL 1) Serial No. 2,001,397 and Higher (BVM-1410P), Serial No. 2,000,021 and Higher (BVM-1410PM), XB board (TALLY), Y board (POWER LED)

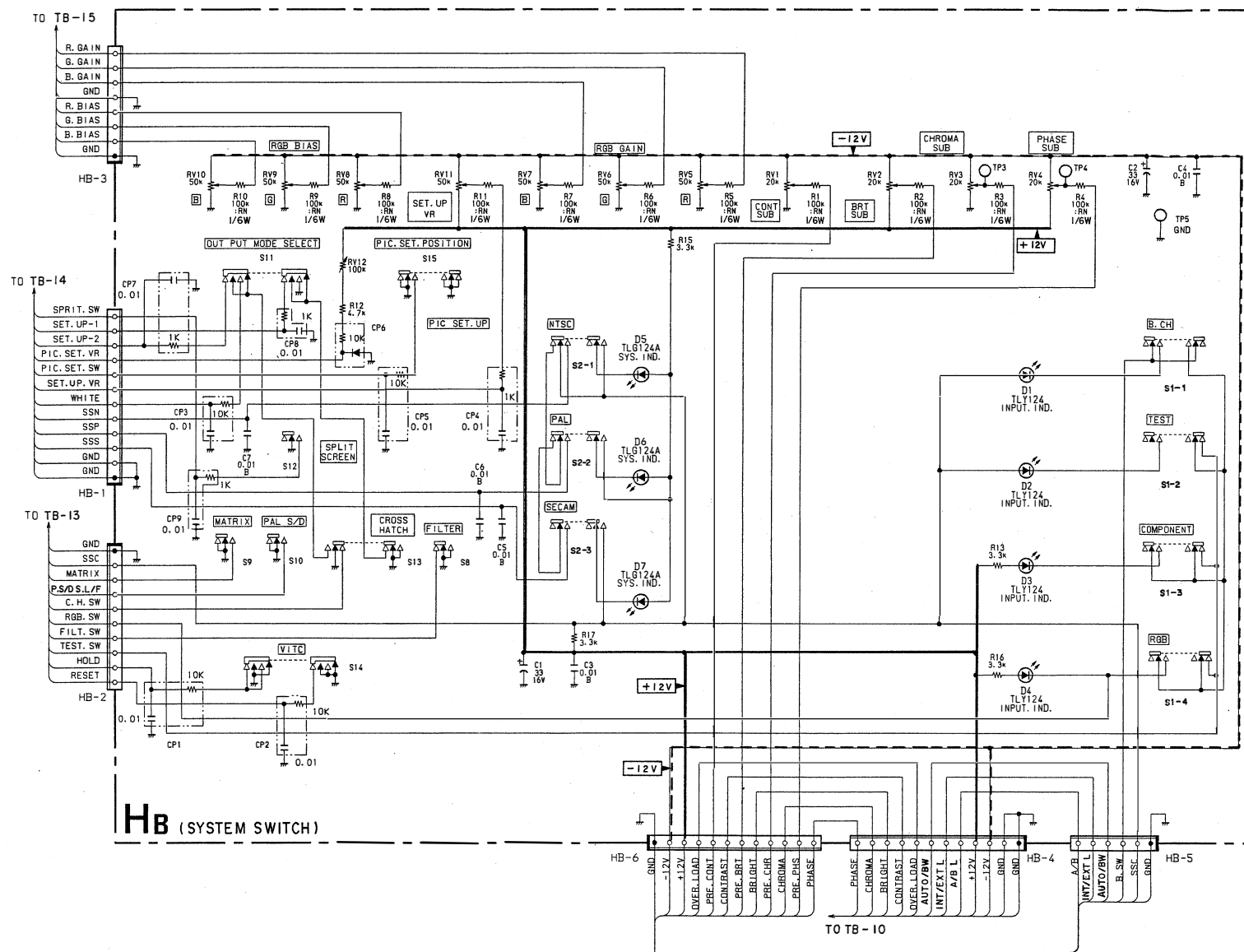

HB (SYSTEM SWITCH)

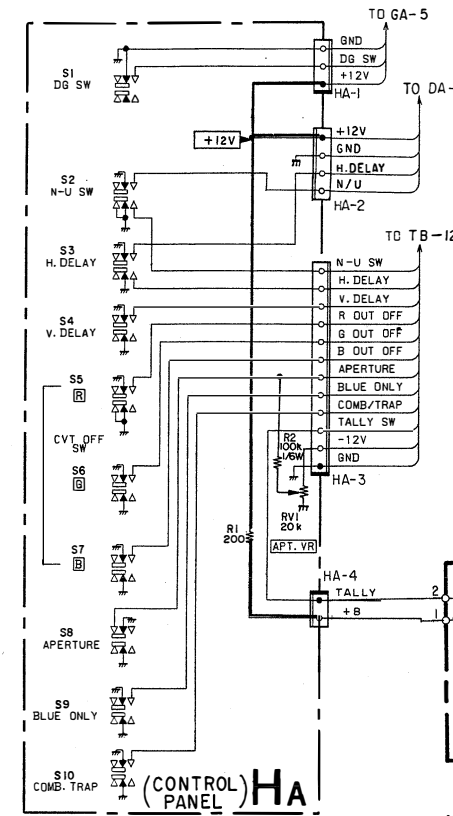

HA (CONTROL PANEL)

Y BOARD

D1	TLG124A	POWER INDICATOR
----	---------	-----------------

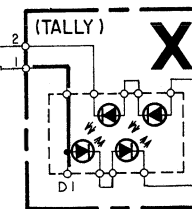
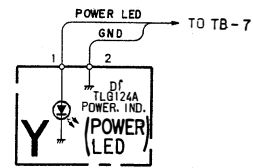

X BOARD

D1	LT-9010H	TALLY LAMP
----	----------	------------

D1	Component	Function
1	TLY124	INPUT MODE INDICATOR
2	TLY124	INPUT MODE INDICATOR
3	TLY124	INPUT MODE INDICATOR
4	TLY124	INPUT MODE INDICATOR
5	TLG124A	SYSTEM INDICATOR
6	TLG124A	SYSTEM INDICATOR
7	TLG124A	SYSTEM INDICATOR

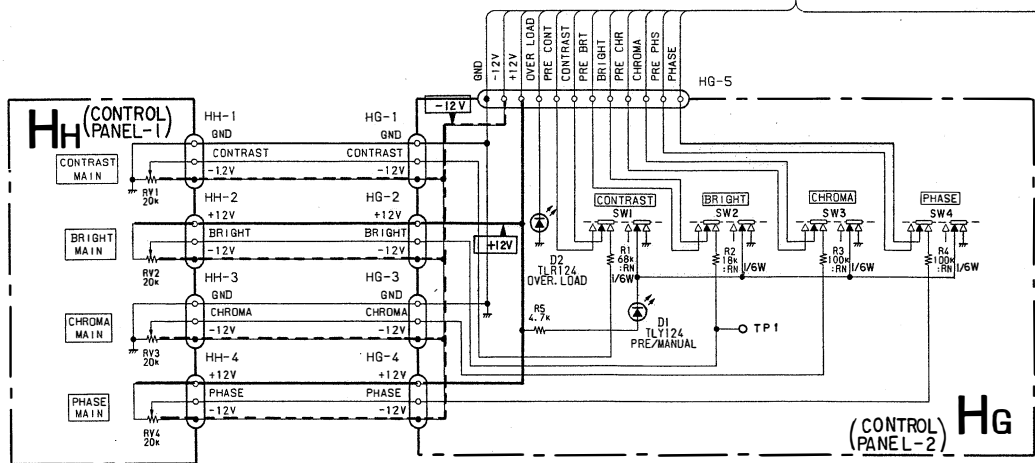

HG/HD BOARD

D1	Component	Function
1	TLY124	PRE/MANUAL INDICATOR
2	TLR124	OVER LOAD INDICATOR

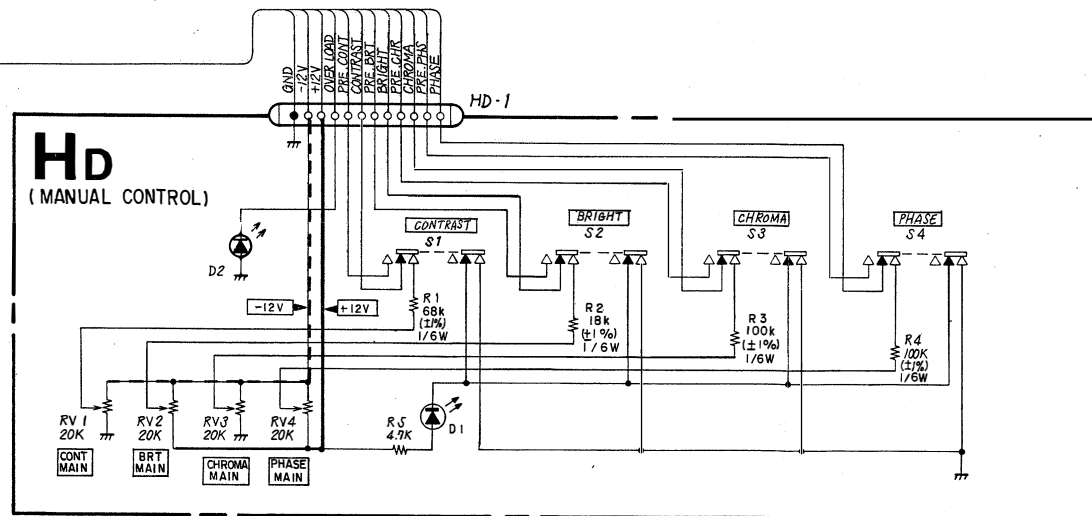

HD (MANUAL CONTROL)

GC, QA, QB, V, W GC, QA, QB, V, W

QA board (COMPOSITE VIDEO INPUT)

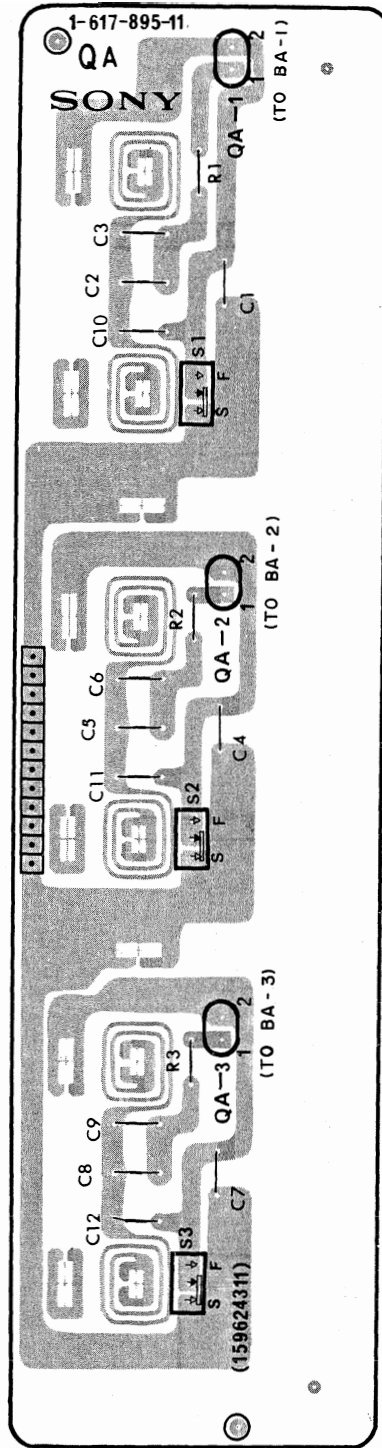

W board (RGB/COMPONENT & VECTOR)

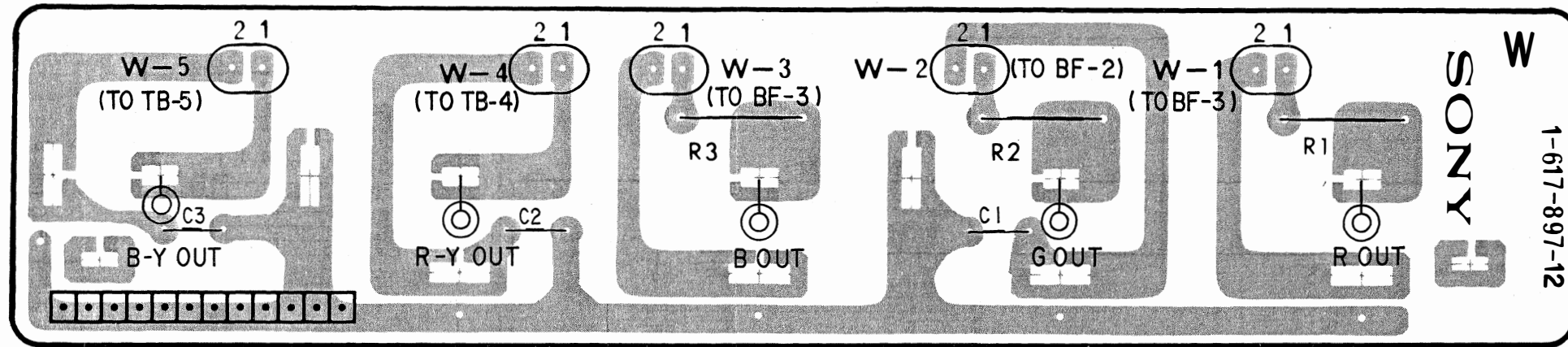

QB board (RGB/COMPONENT INPUT)

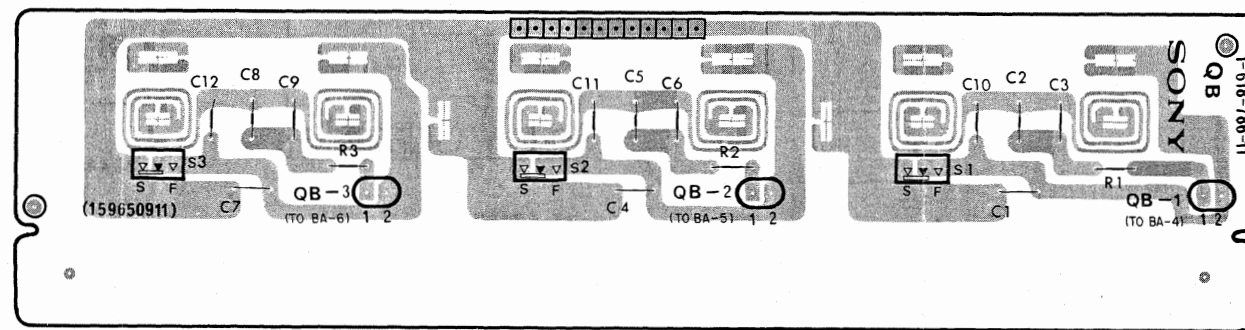

V board (REMOTE)

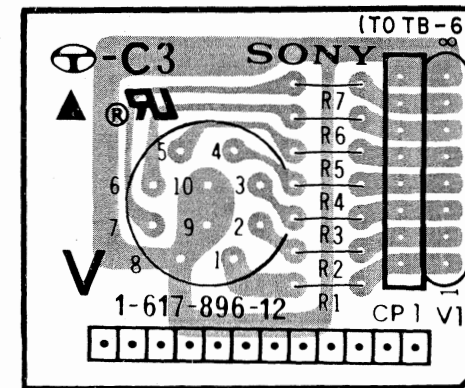

GC board (REG)

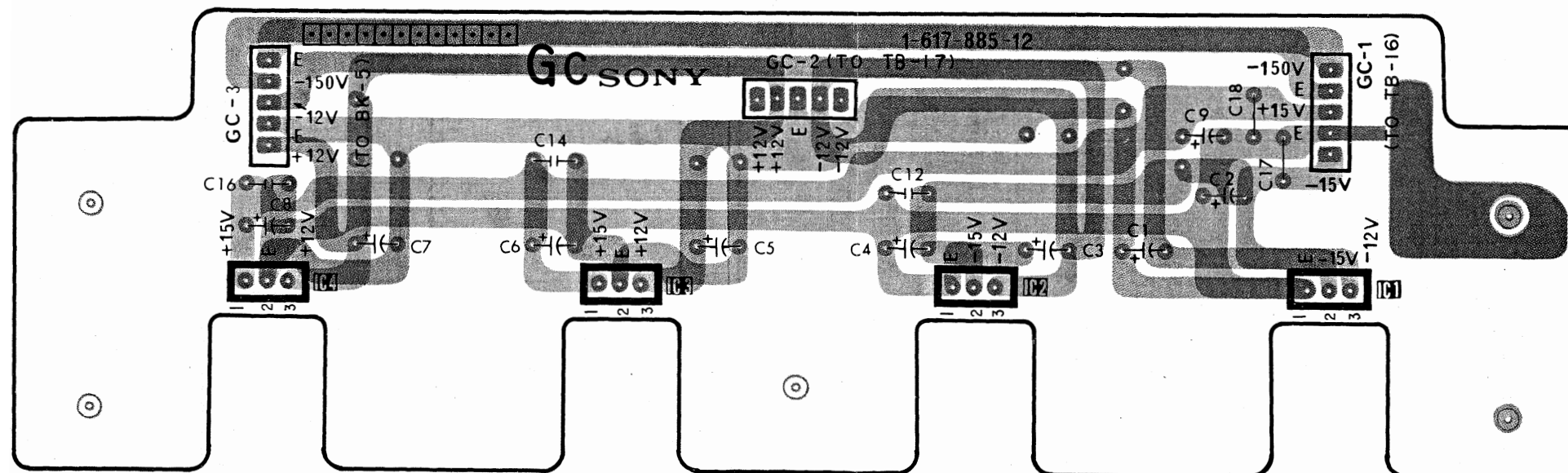

• : Conductor side pattern
 • : Component side pattern

C, PA, PB C, PA, PB

C board (CRT SOCKET)
 PA board (HIGH VOLTAGE PROTECTOR)
 PB board (FBT)

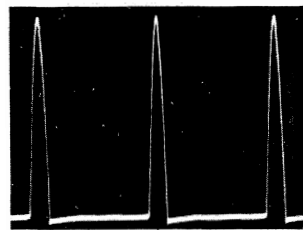
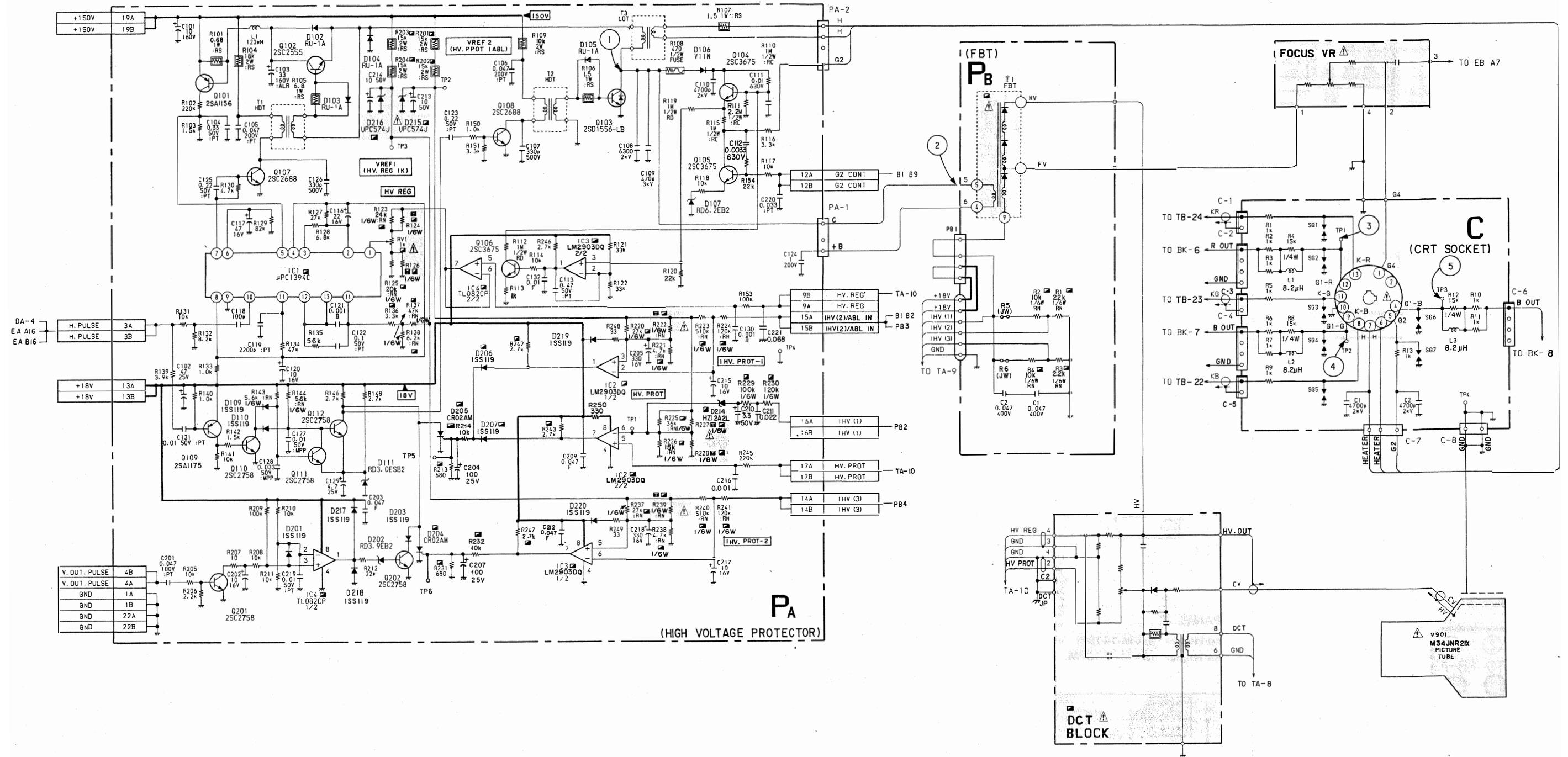

① 1.120Vp-p (H)



② 2.4Ap-p (H)

5-67

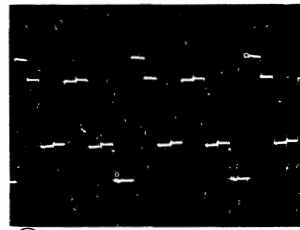

③ 64Vp-p (H)

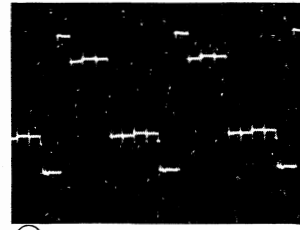

④ 68Vp-p (H)

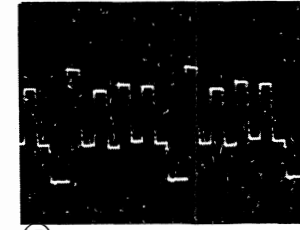

⑤ 61Vp-p (H)

5-68

HC board (INPUT SELECT)

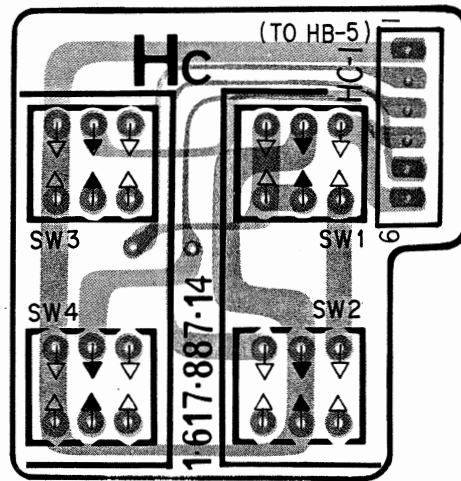

X board (TALLY)

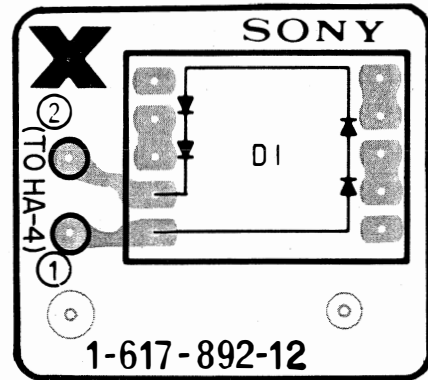

Y board (POWER LED)

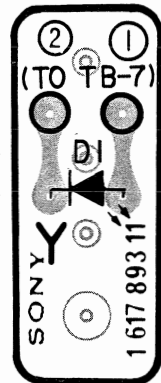

HH board (CONTROL PANEL 1)
Serial No. 2,001,397 and Higher (BVM-1410P)
Serial No. 2,000,021 and Higher (BVM-1410PM)



HD board (MANUAL CONTROL)
Serial No. Up to 2,001,396 (BVM-1410P)
Serial No. Up to 2,000,020 (BVM-1410PM)

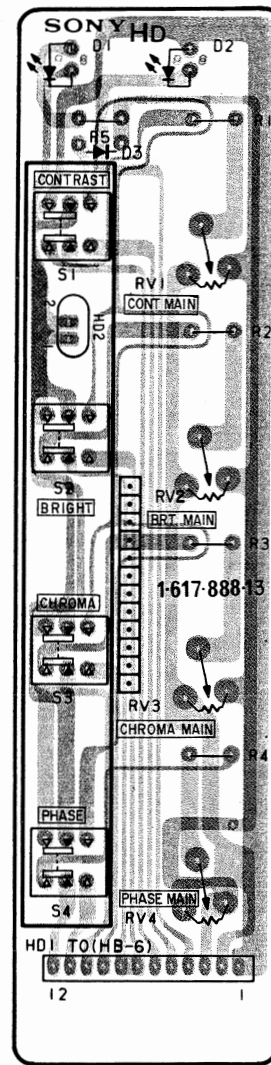

HB board (SYSTEM SWITCH)

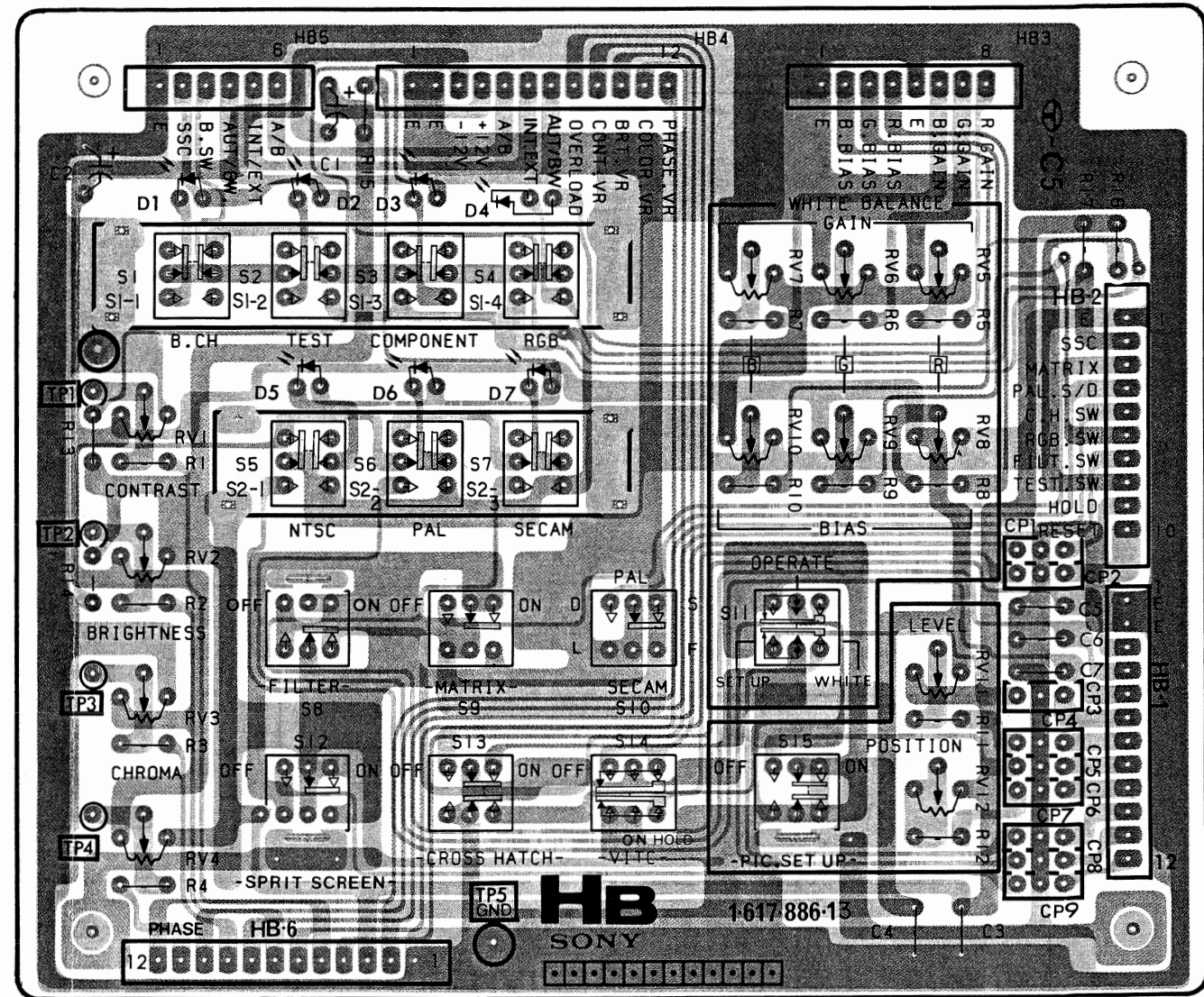

HG board (CONTROL PANEL 2)

Serial No. 2,001,397 and Higher (BVM-1410P)
Serial No. 2,000,021 and Higher (BVM-1410PM)

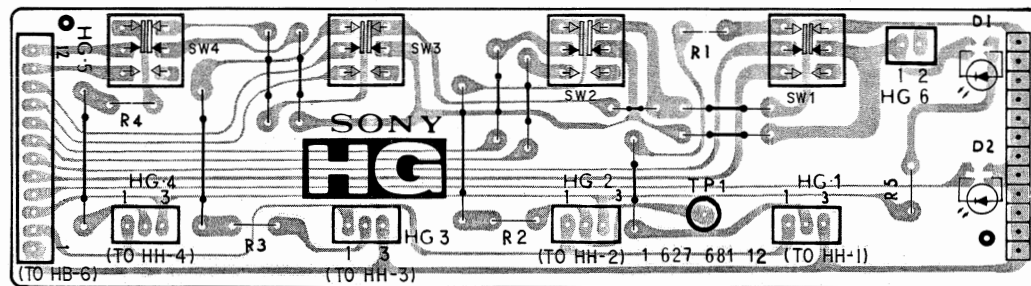

HA board (LEFT CONTROL PANEL)

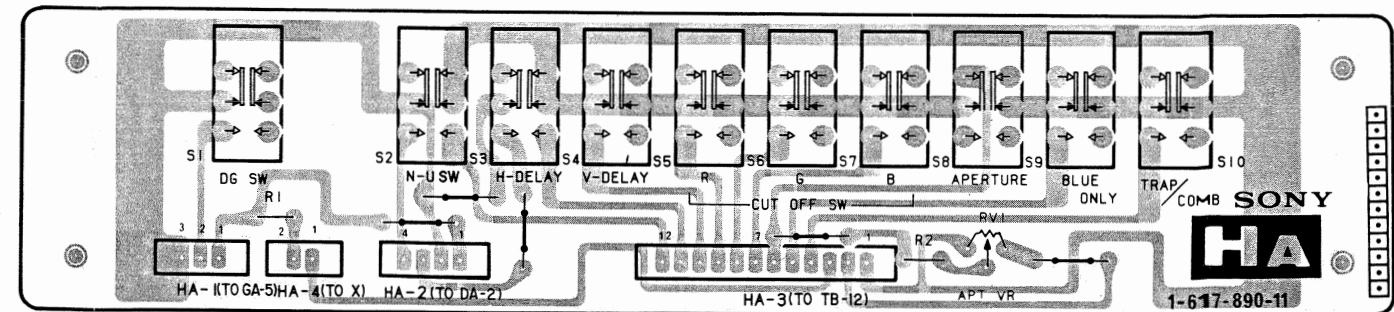

GC, QA, QB, V, W GC, QA, QB, V, W

GC board (REG) QA board (COMPOSITE VIDEO INPUT) QB board (RGB/COMPONENT INPUT)
V board (REMOTE) W board (RGB/COMPONENT & VECTOR)

GC BOARD

IC1	uPC7972H	-12V REG
2	uPC7972H	-12V REG
3	uPC7812H	+12V REG
4	uPC7812H	+12V REG

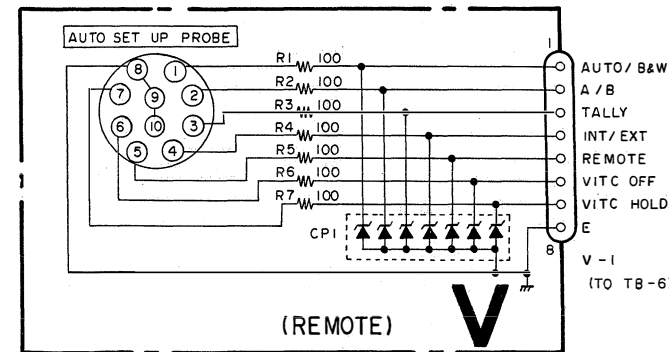
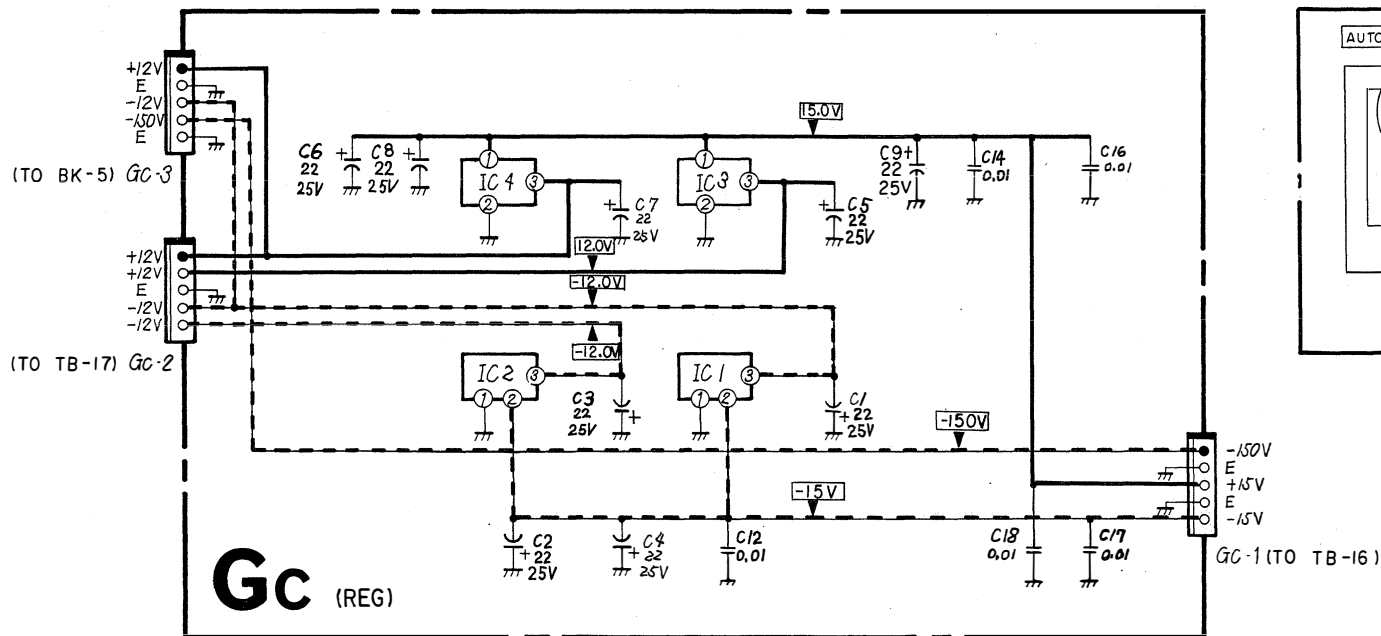
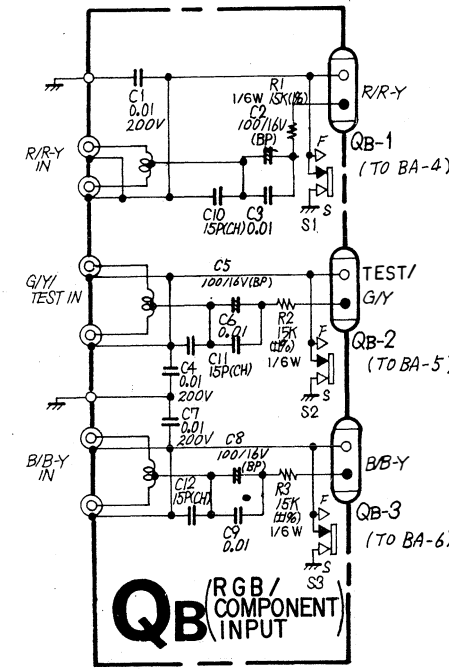
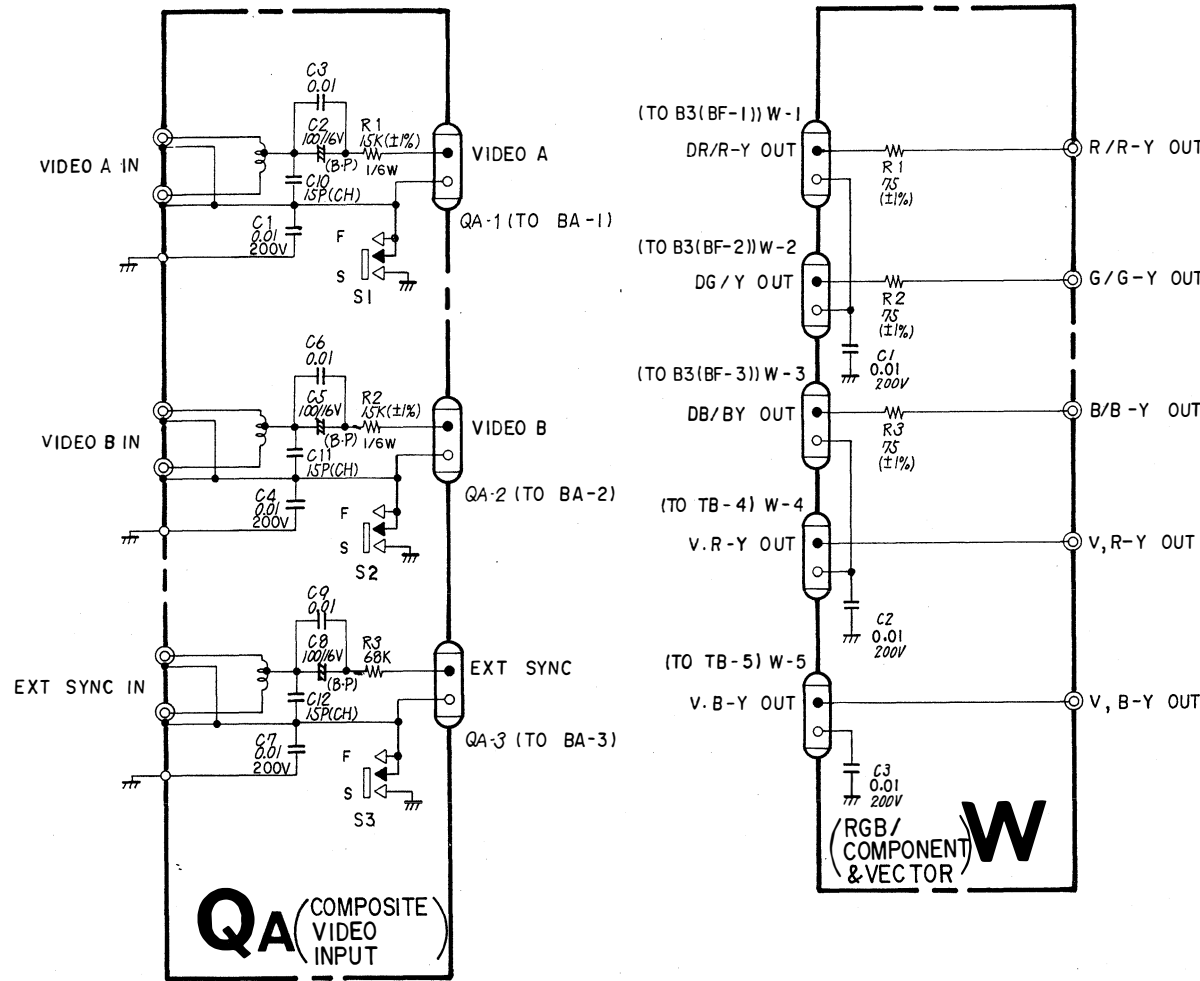

TA board (MOTHER BOARD)

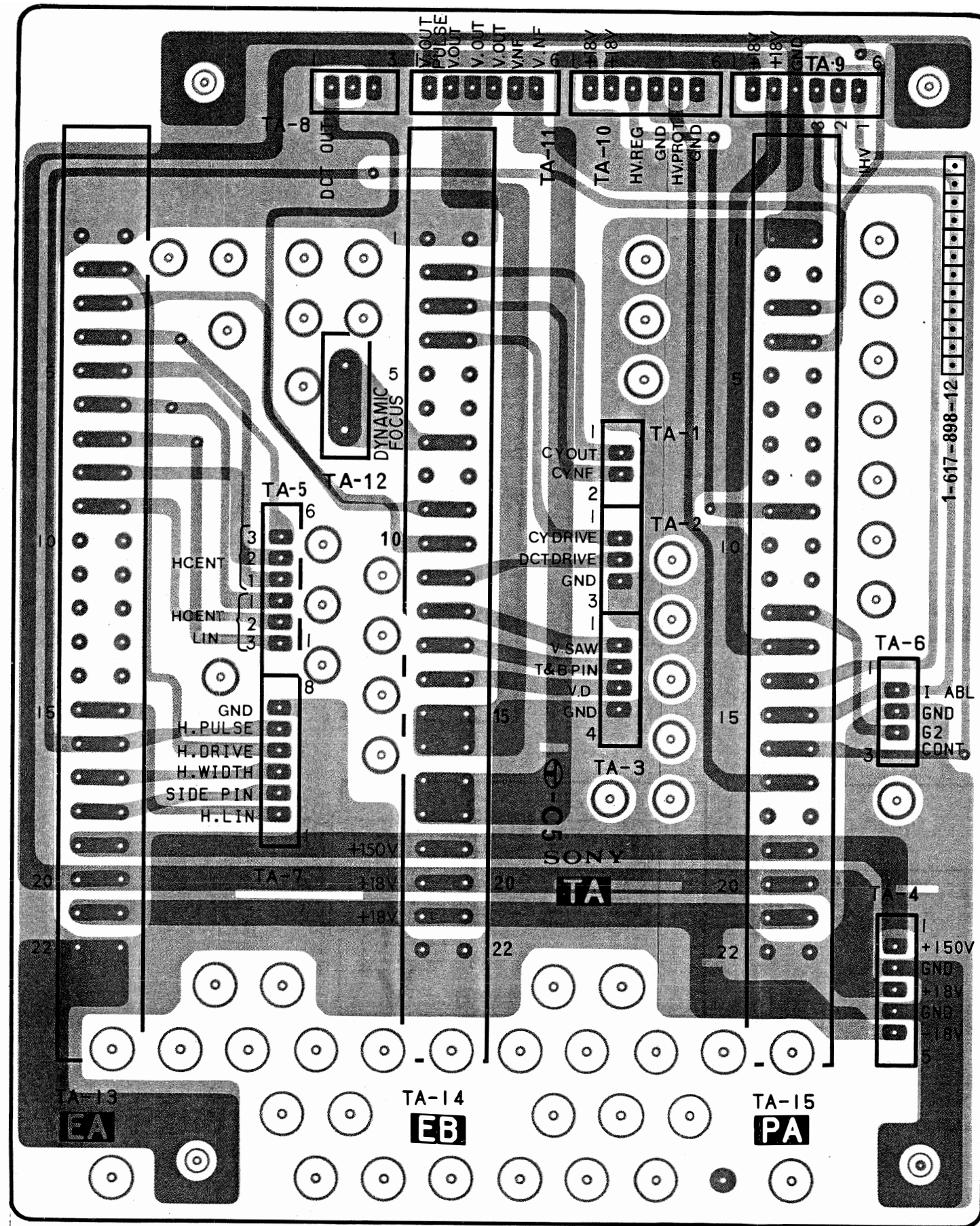

• : Conduct or side pattern
 • : Component side pattern

TA TA

TA board (MOTHER BOARD)

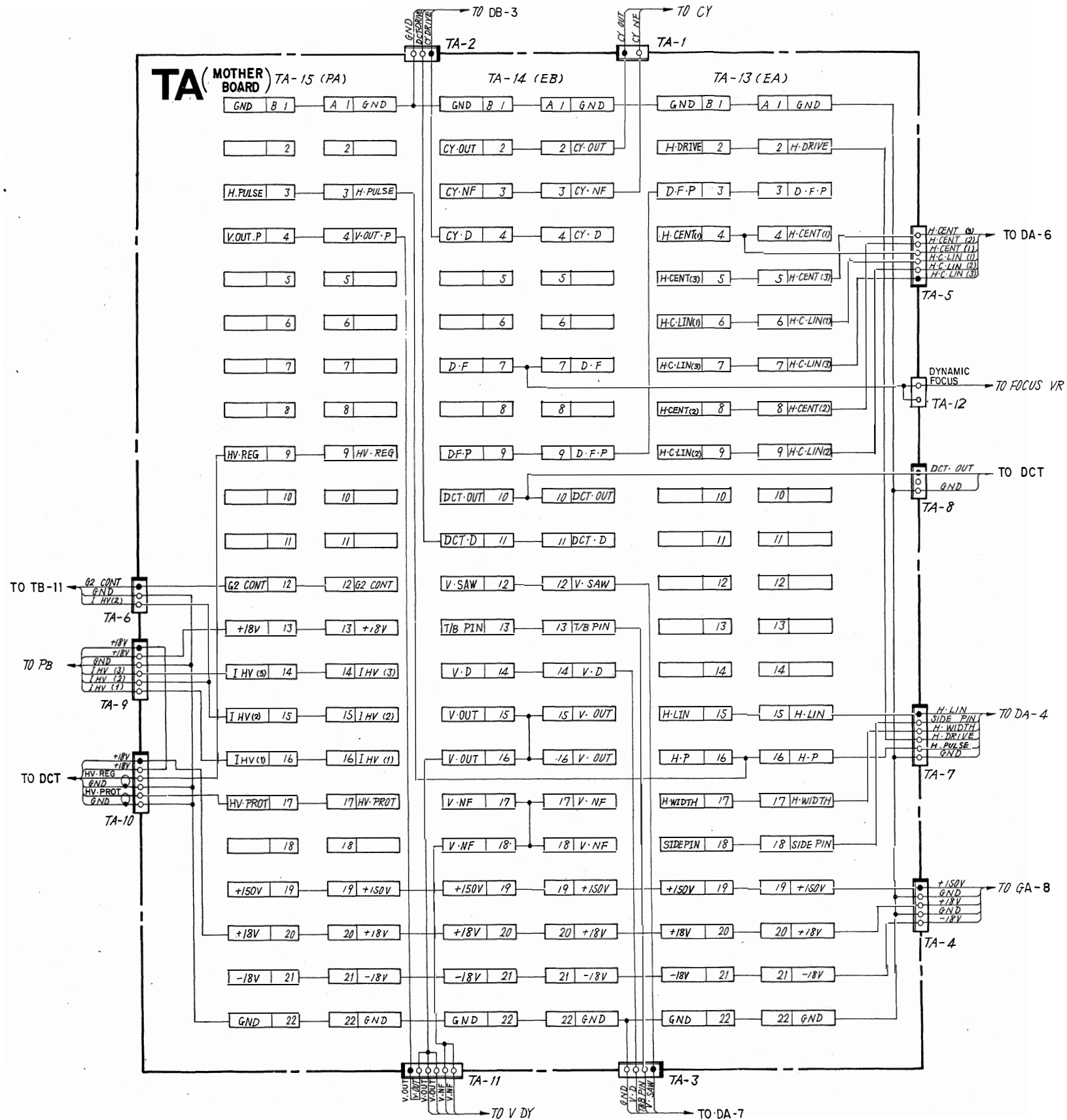

TB board (MOTHER BOARD)

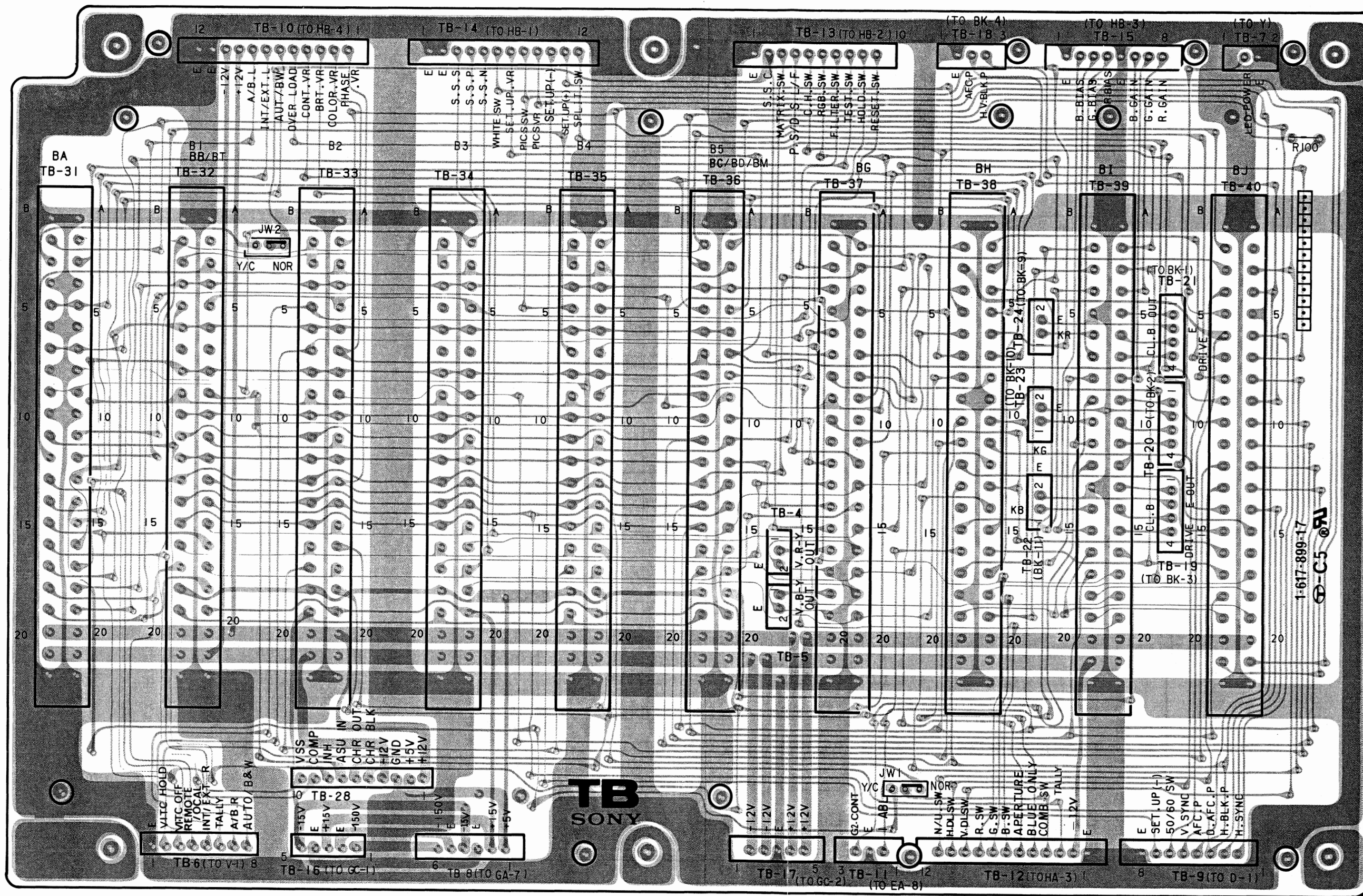

● : Conductor side pattern
 ● : Component side pattern

TB TB

TB board (MOTHER BOARD)

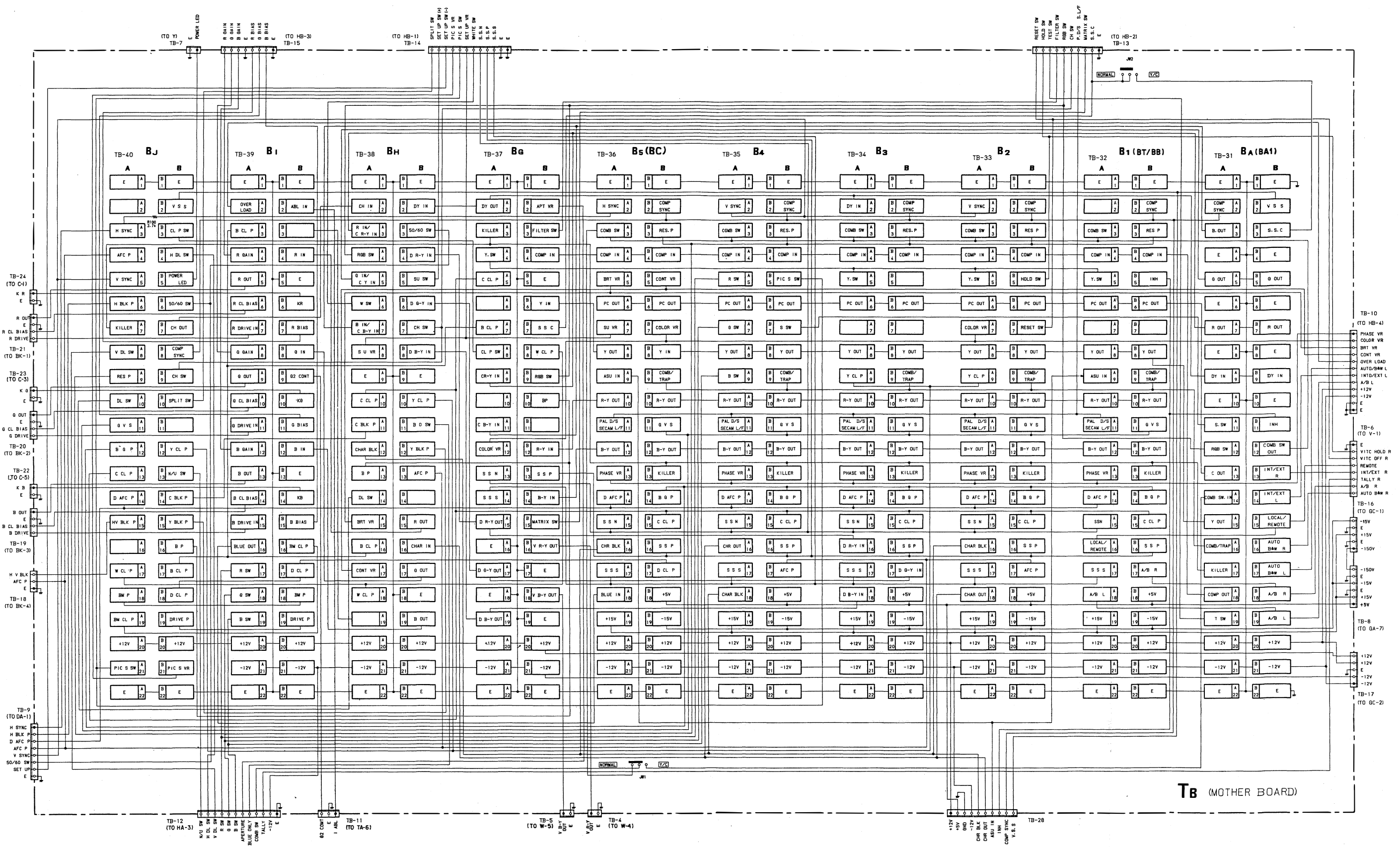

Z Z

Z board (EXTENSION BOARD)

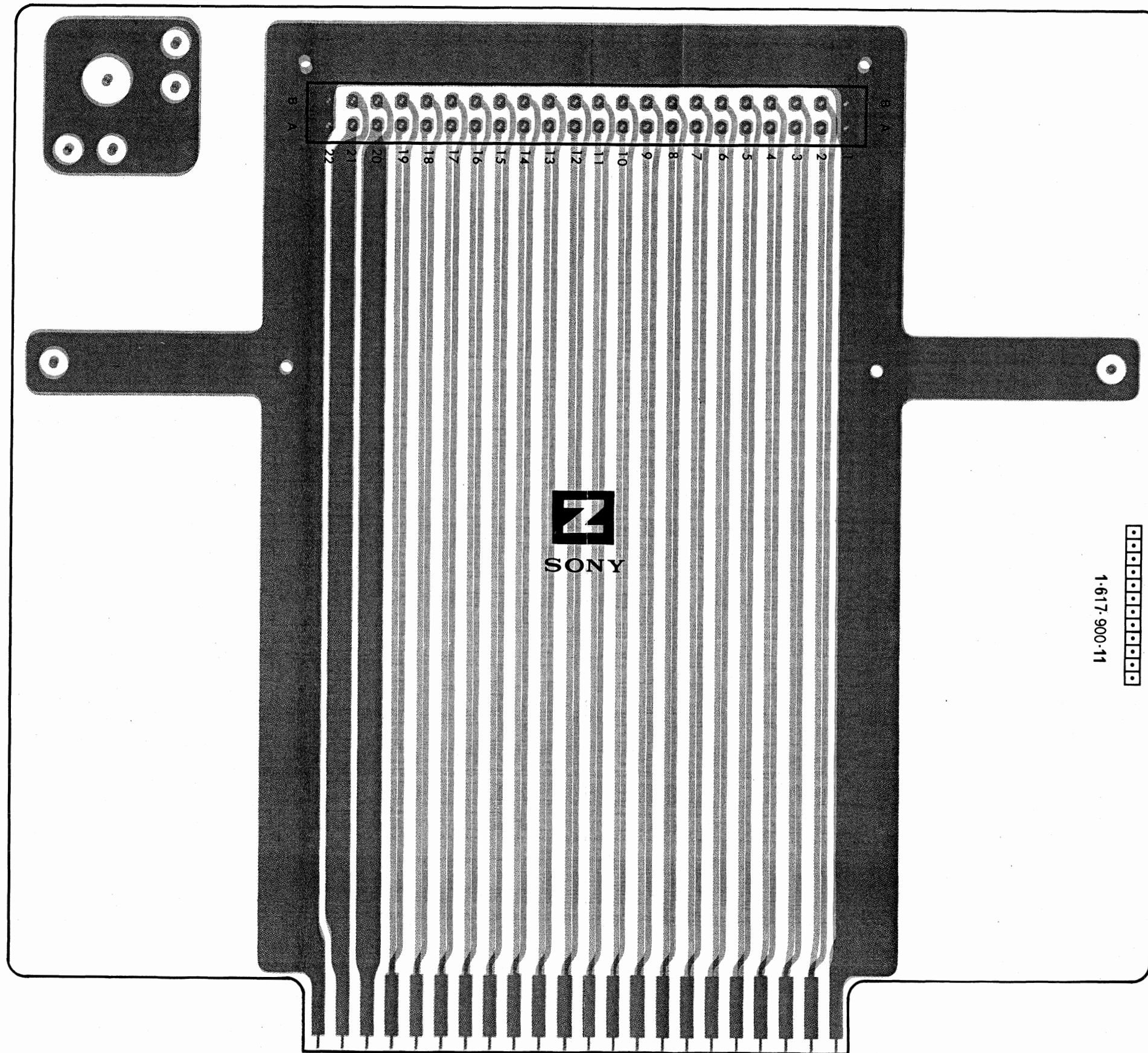

- : Conductor side pattern
- : Component side pattern

5-4. SEMICONDUCTORS

The chart in this section may sometimes show diodes, transistors, and ICs that are not interchangeable. When replacing a component, be sure to refer to the parts list.

The circuit diagram of each IC is obtained from the IC data book published by the manufacturer.

TYPE	PAGE	TYPE	PAGE	TYPE	PAGE	TYPE	PAGE
10E2	5-95	2SD669A	5-94	HD14175BP	5-90	NJM7809FA	5-92
1S1555	5-95	2SD774	5-94	HD14520BP	5-91	NJM7812A	5-92
1S2076	5-95	2SD789	5-94	HD14538BP	5-91	NJM7812B	5-92
1S2835	5-95	2SK381	5-95	HZ10EB3	5-95	NJM78M12A	5-92
1S2837	5-95	2SK514	5-95	HZ12A2L	5-95	NJM7912A	5-92
1S2838	5-95	2SK523-K1	5-95	HZ12EB1	5-95	NJM79M12A	5-92
1SS119	5-95	2SK523-K2	5-95	HZ12EB2	5-95	RB406NH	5-95
1SS133T	5-95	2SK523-L1	5-95	HZ12EB3	5-95	RC7805FA	5-92
1SS148	5-95	BA4558	5-88	HZ15EB3	5-95	RC7809FA	5-92
1SS83	5-95	CR02AM-4	5-95	HZ3.0EB1	5-95	RD10EB3	5-95
1T25	5-95	CR3CM-8	5-95	HZ3.0EB2	5-95	RD12EB1	5-95
2SA1048	5-94	CTU-38R	5-95	HZ3.9EB2	5-95	RD12EB2	5-95
2SA1091	5-94	CTU-38S	5-95	HZ4.3EB1	5-95	RD12EB3	5-95
2SA1115	5-94	CX-718D	5-88	HZ4.3EB2	5-95	RD15EB3	5-95
2SA1142	5-94	CX158	5-88	HZ4.3EB3	5-95	RD3.0EB1	5-95
2SA1156	5-94	CX20061	5-88	HZ5.6EB2	5-95	RD3.0EB2	5-95
2SA1175	5-94	CX23025	5-88	HZ6.2EB1	5-95	RD3.0ES-B	5-95
2SA1226	5-94	CX894	5-88	HZ6.2EB2	5-95	RD3.9EB2	5-95
2SA1406	5-94	CXA1539P	5-88	HZ6.2EB3	5-95	RD4.3EB1	5-95
2SA473	5-94	CXL1009P	5-89	HZ7.5EB2	5-95	RD4.3EB2	5-95
2SA844	5-94	DTA124ES	5-94	HZ7.5EB3	5-95	RD4.3EB3	5-95
2SA893A	5-94	DTA144EK	5-94	HZ9.1EB1	5-95	RD4.7EL1	5-95
2SA933S	5-94	DTA144ES	5-94	HZ9.1EB2	5-95	RD4.7EL2	5-95
2SA979	5-94	DTC124ES	5-94	HZ9.1EB3	5-95	RD4.7EL3	5-95
2SB734	5-94	DTC143TS	5-94	HZT33-02	5-95	RD5.6EB2	5-95
2SB740	5-94	DTC144EK	5-94	LA7016	5-91	RD5.6M-B2	5-95
2SB858	5-94	DTC144ES	5-94	LT-9220H	5-95	RD6.2EB1	5-95
2SB860	5-94	EQA02-06AV3	5-95	M5218L	5-91	RD6.2EB2	5-95
2SB861	5-94	EQA02-07DV3	5-95	M5F7805	5-91	RD6.2EB3	5-95
2SC1173	5-94	EQA02-08AV3	5-95	M5F7809	5-91	RD7.5EB3	5-95
2SC1475	5-94	EQA02-10BV3	5-95	MB84011B	5-89	RD8.2ES-B2	5-95
2SC1740	5-94	EQA02-11DV3	5-95	MB84027B	5-91	RD9.1EB1	5-95
2SC1890A	5-94	EQA02-14BV3	5-95	MB84053B	5-90	RD9.1EB2	5-95
2SC2230A	5-94	ERB81-004	5-95	MB84066B	5-90	RD9.1EB3	5-95
2SC2458	5-94	ERC24-04S	5-95	MC14001BCP	5-89	RH-1	5-95
2SC2551	5-94	ERC24-06S	5-95	MC14011BCP	5-89	RU-1A	5-95
2SC2555	5-94	ERD28-04S	5-95	MC14023BCP	5-89	S3WB60Z	5-96
2SC2603	5-94	ESAC25-04C	5-95	MC14027BCP	5-89	SIB01-02	5-95
2SC2668	5-94	ESAC25-04N	5-95	MC14040BCP	5-89	STR8124	5-92
2SC2688	5-94	ESAC31-02D	5-95	MC14053BCP	5-90	TA7193P	5-93
2SC2752	5-94	ESAD25-04D	5-95	MC14069BCP	5-90	TC4001BP	5-89
2SC2757	5-94	GP08D	5-95	MC14071BCP	5-90	TC4011BP	5-89
2SC2785	5-94	HA17558	5-88	MC14073BCP	5-90	TC40175BP	5-90
2SC2878	5-94	HD14001BP	5-89	MC14081BCP	5-90	TC4023BP	5-89
2SC2910	5-94	HD14011BP	5-89	MC14175BCP	5-90	TC4030BP	5-93
2SC3068	5-94	HD14023BP	5-89	MC14520BCP	5-91	TC4040BP	5-89
2SC3327	5-94	HD14027BP	5-89	MC1496P	5-91	TC4053BP	5-90
2SC3524A	5-94	HD14040BP	5-89	MC911	5-95	TC4066BP	5-90
2SC3600	5-94	HD14053BP	5-90	MC921	5-95	TC4069UBP	5-90
2SC3624A	5-94	HD14066BP	5-90	MC931	5-95	TC4071BP	5-90
2SC3675	5-94	HD14069UBP	5-90	NJM2903D	5-92	TC4073BP	5-90
2SC403SP	5-94	HD14071BP	5-90	NJM4558D	5-88	TC4081BP	5-90
2SD1134	5-94	HD14073BP	5-90	NJM4558S	5-92	TC4093BP	5-90
2SD1137	5-94	HD14081BP	5-90	NJM7805FA	5-92	TC4520BP	5-91
2SD1556	5-95	HD14093BP	5-90				

TYPE	PAGE
TC4538BP	5-91
TC504027BP	5-91
TL082CP	5-93
TL494CN	5-93
TL8608P	5-93
TLG124A	5-96
TLO124	5-96
TLR124	5-96
TLY124	5-96
TX429M	5-93
U05G	5-96
uPC1394C	5-94
uPC4082C	5-93
uPC4558C	5-88
uPC574J	5-94
UPC7812H	5-92
uPC78M12H	5-94
uPC7912H	5-92
uPD4001BC	5-89
uPD4011BC	5-89
uPD4023BC	5-89
uPD4027BC	5-89
uPD4030BC	5-93
uPD4040BC	5-89
uPD4053BC	5-90
uPD4066BC	5-90
uPD4069UBC	5-90
uPD4071BC	5-90
uPD4073BC	5-90
uPD4081BC	5-90
uPD4175BC	5-90
uPD4538BC	5-91
V11N	5-96

CX158 (SONY)
HORIZONTAL DEFLECTION OSCILLATOR/FREQUENCY LIMITER
- TOP VIEW -

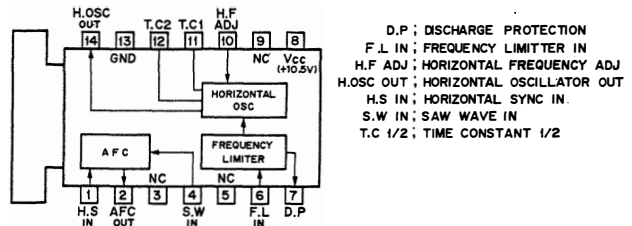

D.P ; DISCHARGE PROTECTION
F.L IN ; FREQUENCY LIMITER IN
H.F ADJ ; HORIZONTAL FREQUENCY ADJ
H.OSC OUT ; HORIZONTAL OSCILLATOR OUT
H.S IN ; HORIZONTAL SYNC IN
S.W IN ; SAW WAVE IN
T.C 1/2 ; TIME CONSTANT 1/2

CX20061 (SONY)
ANALOG SWITCH
- SIDE VIEW -

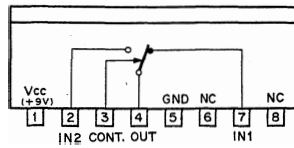

CONT.	SW
0	
1	

0 ; LOW LEVEL
1 ; HIGH LEVEL

CX23025 (SONY)
C-MOS TV-VTR SYNC. SIGNAL DISCRIMINATOR
- TOP VIEW -

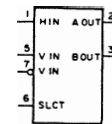
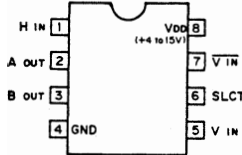

A OUT ; SYNC SIGNAL DISCRIMINATION OUTPUT
B OUT ; SYNC SIGNAL DISCRIMINATION OUTPUT
H IN ; HORIZONTAL SYNC INPUT
SLCT ; POWER ON INITIALIZED SELECT INPUT
V IN ; VERTICAL SYNC INPUT
V IN ; VERTICAL SYNC INPUT

POWER ON INITIALIZED			
SLCT	INPUT	A OUTPUT	B OUTPUT
1	0	0	1
0	0	1	0

DISCRIMINATION			
V SYNC INPUT	FREQUENCY		OUTPUTS
	A	B	
50Hz	0	1	
60Hz	1	0	

0 ; LOW LEVEL
1 ; HIGH LEVEL

BA4558 (ROHM)
HA17558 (HITACHI)
NJM4558D (JRC)
uPC4558C (NEC)

OPERATIONAL AMPLIFIER
- TOP VIEW -

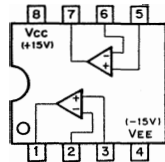

CX-718D (SONY)
SRG FET IC
- TOP VIEW -

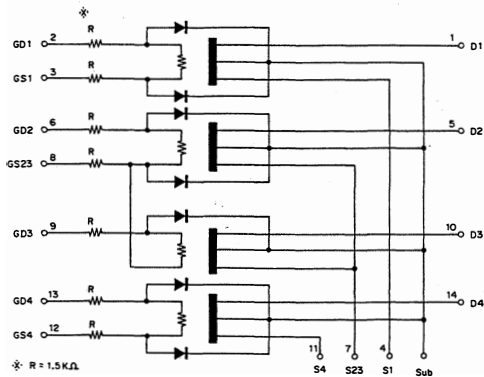
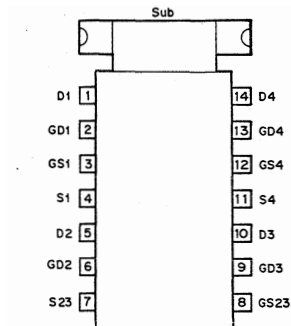

CX894 (SONY)
3 INPUT SWITCH
- SIDE VIEW -

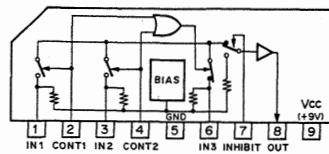

CXA1539P (SONY)

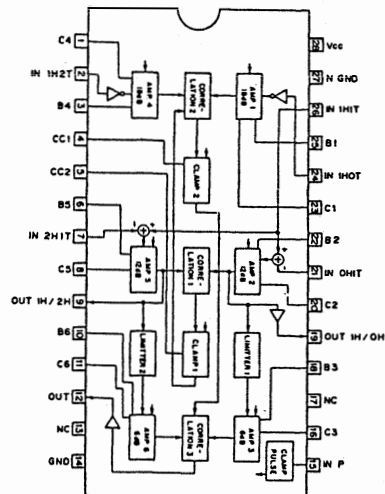

CXL1009P (SONY)
C-MOS CCD SIGNAL PROCESSOR FOR TBC
 - TOP VIEW -

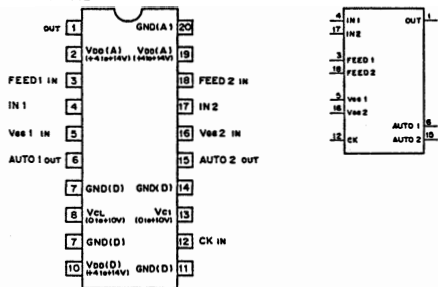

OUT ; OUT PUT
 FEED 1/2 IN ; FEEDBACK INPUT 1/2
 IN 1/2 ; INPUT 1/2
 Vee 1/2 IN ; GATE INPUT 1/2
 AUTO 1/2 OUT ; AUTO BIAS OUTPUT 1/2
 CK IN ; CLOCK INPUT
 VCL ; POWER SUPPLY 2 (DIGITAL)
 Vee (A1)/(D) ; POWER SUPPLY 1 (ANALOG)/(DIGITAL)
 GND(A1)/(D) ; GROUND (ANALOG)/(DIGITAL)

HD14023BP
MC14023BCP (MOTOROLA)
TC4023BP (TOSHIBA)
uPD4023BC (NEC)
C-MOS 3-INPUT NAND GATE
 - TOP VIEW -

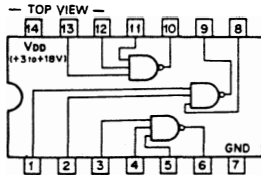

$Y = A \cdot B \cdot C$
 $Y = \bar{A} + \bar{B} + \bar{C}$

A	B	C	Y
X	X	0	1
X	0	X	1
0	X	X	1
1	1	1	0
1	1	0	X

0: LOW LEVEL
 1: HIGH LEVEL
 X: DON'T CARE

HD14027BP (HITACHI)
MC14027BCP (MOTOROLA)
uPD4027BC (NEC)
C-MOS J-K MASTER SLAVE FLIP-FLOP WITH DIRECT SET/RESET
 - TOP VIEW -

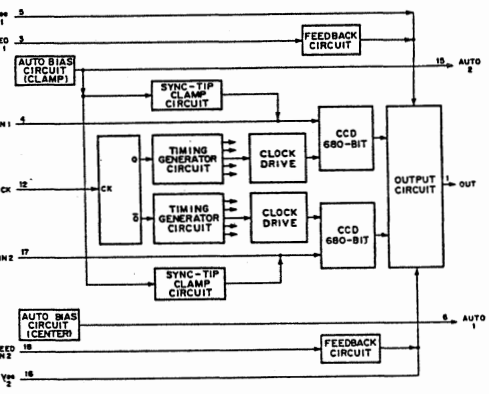
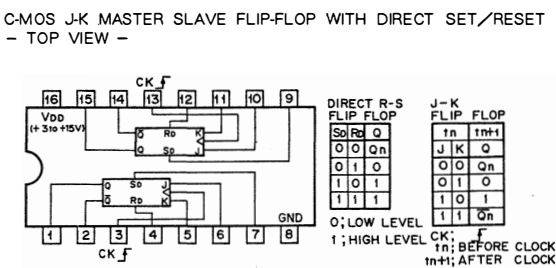

HD14040BP (HITACHI)
MC14040BCP (MOTOROLA)
TC4040BP (TOSHIBA)
uPD4040BC (NEC)
C-MOS 12-STAGE RIPPLE CARRY BINARY COUNTER/DRIVER
 - TOP VIEW -

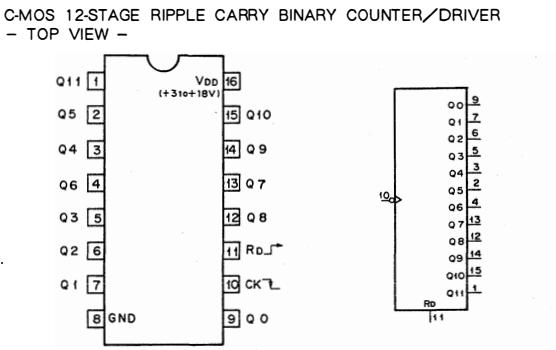

COUNT	Q11	Q10	Q9	Q8	Q7	Q6	Q5	Q4	Q3	Q2	Q1	Q0	Rd	Q11	Q10	Q9	Q8	Q7	Q6	Q5	Q4	Q3	Q2	Q1	Q0
0	0	0	0	0	0	0	0	0	0	0	0	0	0	1	ALL	LOW									
1	0	0	0	0	0	0	0	0	0	0	0	0	0	0	COUNT										
2	0	0	0	0	0	0	0	0	0	0	0	0	0	0											
3	0	0	0	0	0	0	0	0	0	0	0	0	0	0											
...											
4095	1	1	1	1	1	1	1	1	1	1	1	1	1	1											

0: LOW LEVEL
 1: HIGH LEVEL

HD14001BP (HITACHI)
MC14001BCP (MOTOROLA)
TC4001BP (TOSHIBA)
uPD4001BC (NEC)
C-MOS 2-INPUT NOR GATE
 - TOP VIEW -

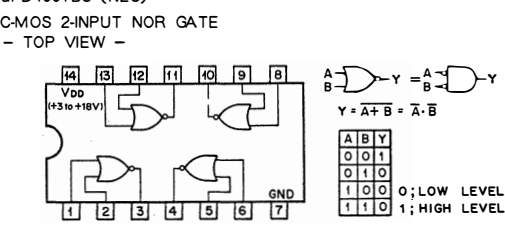

HD14011BP (HITACHI)
MB84011B (FUJITSU)
MC14011BCP (MOTOROLA)
TC4011BP (TOSHIBA)
uPD4011BC (NEC)
C-MOS 2-INPUT NAND GATE
 - TOP VIEW -

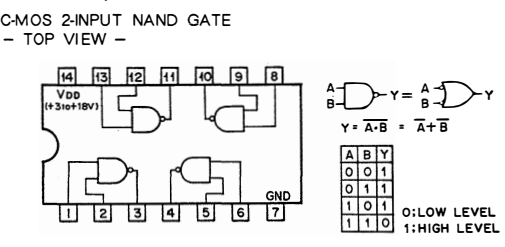

HD14053BP (HITACHI)
 MB84053B (FUJITSU)
 MC14053BCP (MOTOROLA)
 TC4053BP (TOSHIBA)
 UPD4053BC (NEC)

C-MOS TRIPLE 2-CHANNEL ANALOG MULTIPLEXER/DEMULTIPLEXER
 - TOP VIEW -

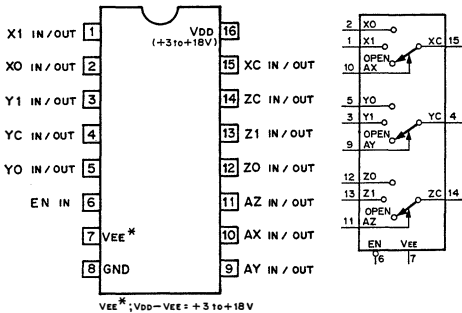

CONT. INPUTS		ON CHANNEL	
EN	A (X,Y,Z)		
0	0	0	0
0	1	1	1
1	X		OPEN

0; LOW LEVEL
 1; HIGH LEVEL
 X; DON'T CARE.

HD14066BP (HITACHI)
 MB84066B (FUJITSU)
 TC4066BP (TOSHIBA)
 UPD4066BC (NEC)

C-MOS BILATERAL ANALOG SWITCH
 - TOP VIEW -

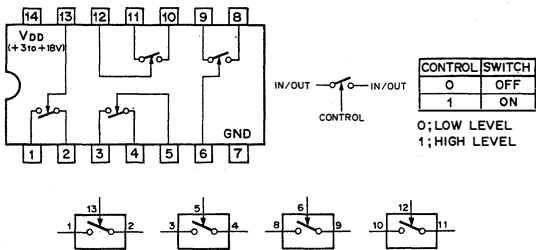

CONTROL	SWITCH
0	OFF
1	ON

0; LOW LEVEL
 1; HIGH LEVEL

HD14069UBP (HITACHI)
 MC14069BCP (MOTOROLA)
 TC4069UBP (TOSHIBA)
 UPD4069UBC (NEC)

C-MOS INVERTER
 - TOP VIEW -

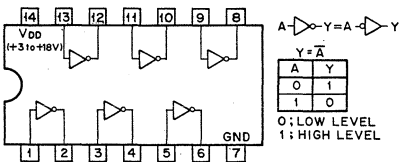

A	Y
0	1
1	0

0; LOW LEVEL
 1; HIGH LEVEL

HD14071BP (HITACHI)
 MC14071BCP (MOTOROLA)
 TC4071BP (TOSHIBA)
 UPD4071BC (NEC)

C-MOS 2-INPUT OR GATE
 - TOP VIEW -

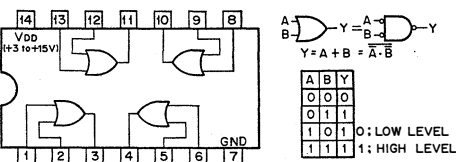

A	B	Y
0	0	0
0	1	1
1	0	1
1	1	1

0; LOW LEVEL
 1; HIGH LEVEL

HD14073BP (HITACHI)
 MC14073BCP (MOTOROLA)
 TC4073BP (TOSHIBA)
 UPD4073BC (NEC)

C-MOS 3-INPUT POSITIVE AND GATE
 - TOP VIEW -

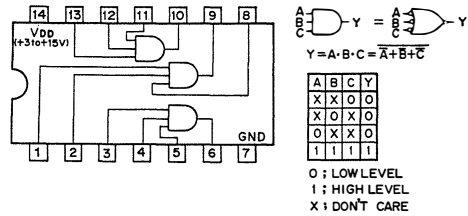

A	B	C	Y
X	X	0	0
X	0	X	0
0	X	X	0
1	1	1	1

0; LOW LEVEL
 1; HIGH LEVEL
 X; DON'T CARE

HD14081BP (HITACHI)
 MC14081BCP (MOTOROLA)
 TC4081BP (TOSHIBA)
 UPD4081BC (NEC)

C-MOS 2-INPUT AND GATE
 - TOP VIEW -

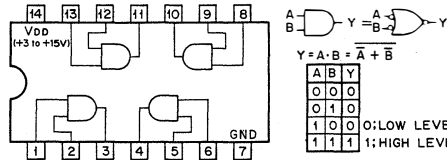

A	B	Y
0	0	0
0	1	0
1	0	0
1	1	1

0; LOW LEVEL
 1; HIGH LEVEL

HD14093BP (HITACHI)
 TC4093BP (TOSHIBA)

C-MOS 2-INPUT NAND SCHMITT TRIGGER
 - TOP VIEW -

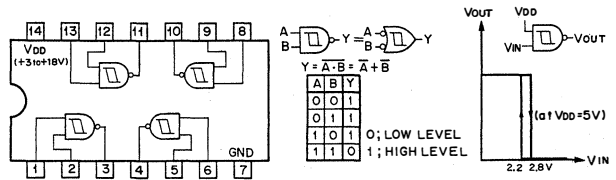

A	B	Y
0	0	1
0	1	1
1	0	1
1	1	0

0; LOW LEVEL
 1; HIGH LEVEL

HD14175BP (HITACHI)
 MC14175BCP (MOTOROLA)
 TC40175BP (TOSHIBA)
 UPD4175BC (NEC)

C-MOS D-TYPE FLIP-FLOP
 - TOP VIEW -

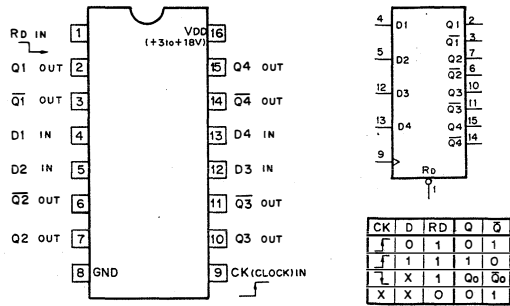

CK	D	RD	Q	Q
0	0	1	0	1
0	1	1	1	0
1	X	1	Q0	Q0
X	X	0	0	1

0; LOW LEVEL
 1; HIGH LEVEL
 X; DON'T CARE

HD14520BP (HITACHI)
 MC14520BCP (MOTOROLA)
 TC4520BP (TOSHIBA)

C-MOS DUAL 4-BIT BINARY UP COUNTER
 - TOP VIEW -

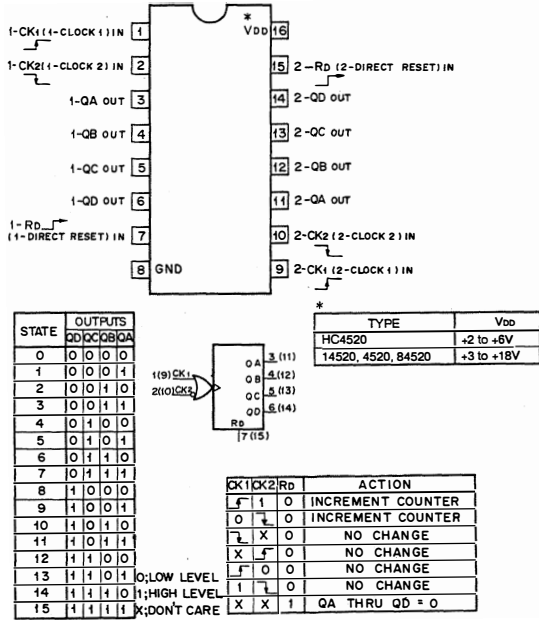

M5218L (MITSUBISHI)
 LOW NOISE DUAL OPERATIONAL AMPLIFIER
 - SIDE VIEW -

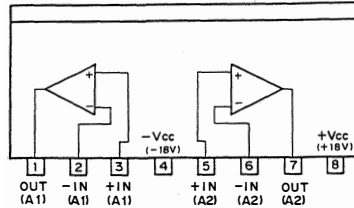

M5F7805 (MITSUBISHI) + 5V
 M5F7809 (MITSUBISHI) + 9V
 POSITIVE VOLTAGE REGULATOR (1A)
 - PRINTED SIDE VIEW -

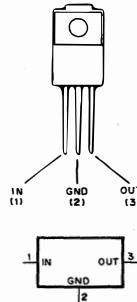

HD14538BP (HITACHI)
 TC4538BP (TOSHIBA)
 uPD4538BC (NEC)

C-MOS DUAL RETRIGGERABLE MONOSTABLE MULTIVIBRATOR
 - TOP VIEW -

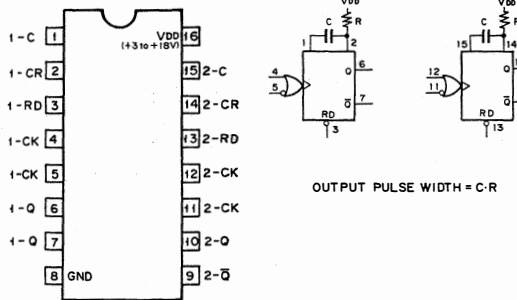

RETRIGGERABLE M.M.V

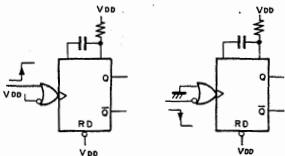

NON-RETRIGGERABLE M.M.V

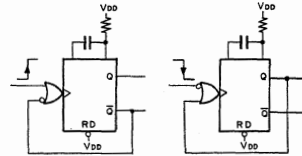

MB84027B (FUJITSU)
 TC504027BP (TOSHIBA)
 C-MOS J-K MASTER SLAVE FLIP-FLOP WITH DIRECT SET/RESET
 - TOP VIEW -

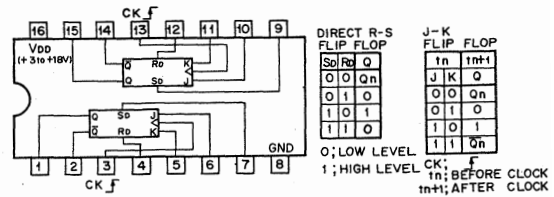

MC14023BCP (MOTOROLA)
 TC4023BP (TOSHIBA)
 uPD4023BC (NEC)

C-MOS 3-INPUT NAND GATE
 - TOP VIEW -

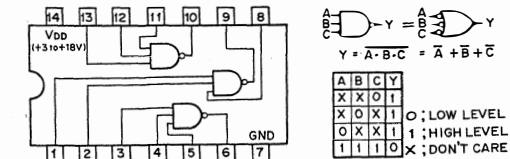

MC1496P (MOTOROLA)
 BALANCED MODULATOR/DEMODULATOR
 - TOP VIEW -

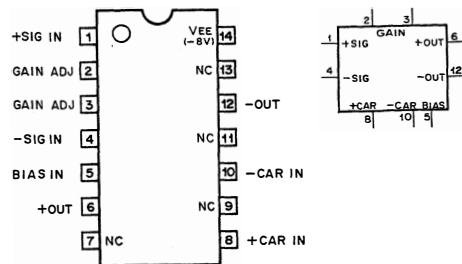

LA7016 (SANYO)
 ELECTRONIC SWITCH
 - SIDE VIEW -

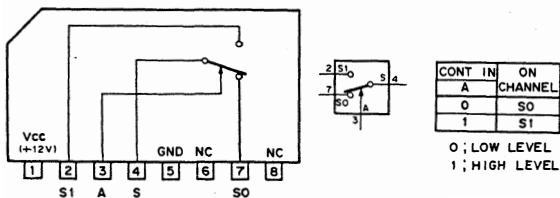

NJM2903D (JRC)
 DUAL VOLTAGE COMPARATORS
 - TOP VIEW -

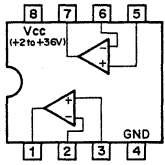

NJM4558S (JRC)
 HIGH PERFORMANCE DUAL OPERATIONAL AMPLIFIER
 - SIDE VIEW -

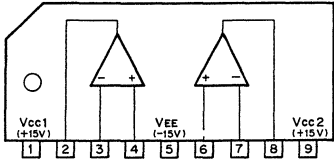

NJM7805FA (JRC) + 5V
 NJM7809FA (JRC) + 9V
 RC7805FA (RAYTHEON) + 5V
 RC7809FA (RAYTHEON) + 9V
 POSITIVE VOLTAGE REGULATOR
 - FRONT VIEW -

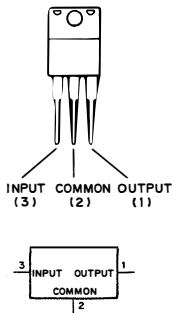

NJM7812A (JRC) + 12V
 NJM7812B (JRC) + 12V
 UPC7812H (NEC) + 12V
 POSITIVE VOLTAGE REGULATOR (1A)
 - SIDE VIEW -

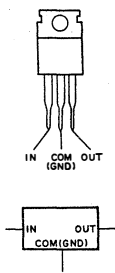

NJM78M12A (JRC) + 12V
 POSITIVE VOLTAGE REGULATOR (500mA)
 - FRONT VIEW -

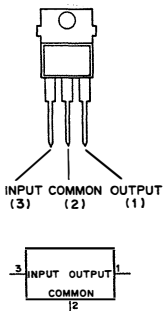

NJM7912A (JRC) - 12V
 uPC7912H (NEC) - 12V
 NEGATIVE VOLTAGE REGULATOR (1A)
 - SIDE VIEW -

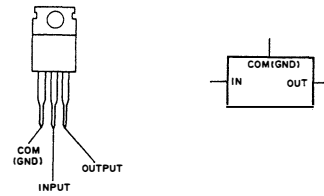

NJM79M12A (JRC) - 12V
 NEGATIVE VOLTAGE REGULATOR (500mA)
 - FRONT VIEW -

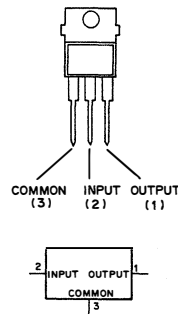

STR8124

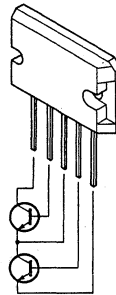

b. DIAGRAMS

TA7193P (TOSHIBA)
TV CHROMA PROCESS (PAL)
- TOP VIEW -

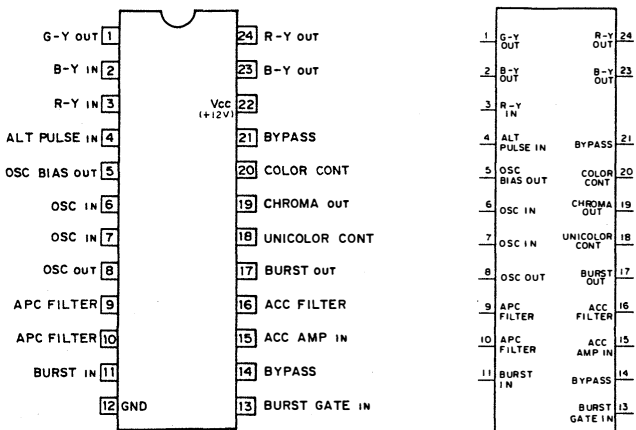

OUT; OUTPUT
IN; INPUT
CONT; CONTROL

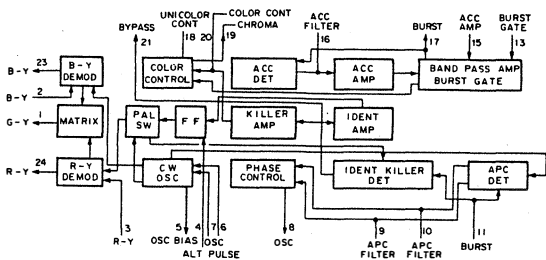

TC4030BP (TOSHIBA)
uPC4030BC (NEC)
C-MOS EXCLUSIVE OR GATE
- TOP VIEW -

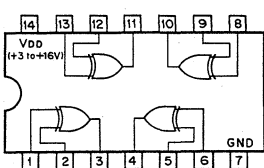

$Y = A \cdot B + A \cdot \bar{B}$

A	B	Y
0	0	0
0	1	1
1	0	1
1	1	0

 0: LOW LEVEL
1: HIGH LEVEL

TL082CP (TI)
uPC4082C (NEC)
OPERATIONAL AMPLIFIER
(J FET-INPUT)
- TOP VIEW -

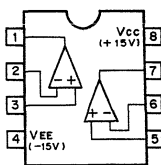

TL494CN (TI)
PWM POWER CONTROL
- TOP VIEW -

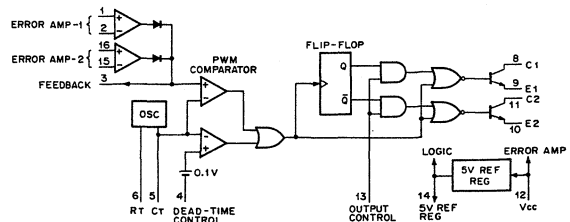
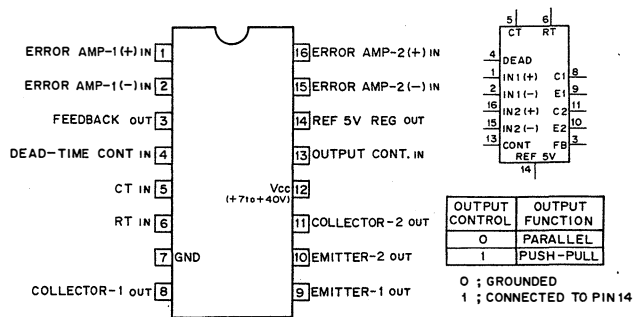

TL8608P (TOSHIBA)
N-CH CCD ANALOG PROCESSING UNIT
- TOP VIEW -

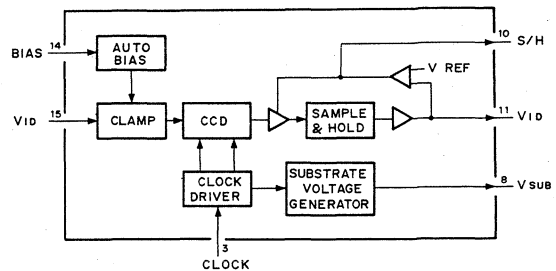
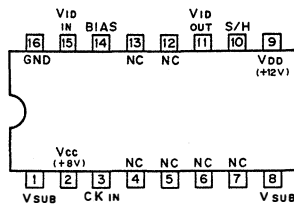

TX429M

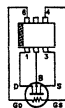

μPC1394C (NEC)
CONTROLLER OF SWITCHING MODE POWER SUPPLY
— TOP VIEW —

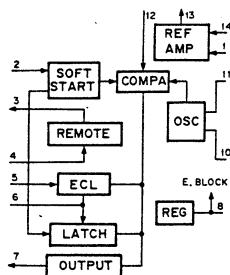
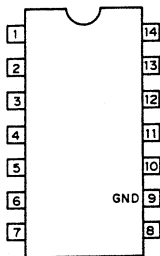

uPC574J

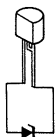

uPC78M12H (NEC) + 12V
POSITIVE VOLTAGE REGULATOR (0.5A)
— SIDE VIEW —

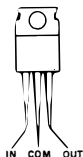

2SA1091
2SA844
2SA933S
2SC1740
2SC1890A
2SC2551
2SC2878
2SC3068



2SA1048
2SA1115
2SC3327
2SC2458
2SC2603
2SC2668
2SC403SP
DTA124ES
DTA144ES
DTC124ES
DTC143TS
DTC144ES



2SA1142
2SA1156
2SC2688
2SC2752
2SD669A

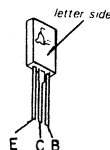

2SA1175
2SC2785



2SA1226
2SC2757
2SC3524A
2SC3624A
DTA144EK
DTC144EK



2SA1406
2SC3600



2SA473
2SB858
2SB860
2SB861
2SC1173
2SC3675
2SD1134
2SD1137

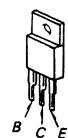

2SA893A
2SB740
2SC1475
2SC2230A
2SC2910
2SD789



2SA979



2SB734
2SD774



2SC2555

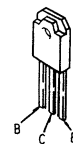

2SD1556



2SK381



2SK514

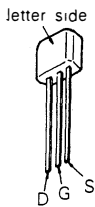

2SK523-K1
2SK523-K2
2SK523-L1



1SS119
1SS133T
1SS148
RD3.0ES-B
RD8.2ES-B2

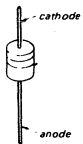

1SS83
1S1555
1S2076
EQA02-06AV3
EQA02-07DV3
EQA02-08AV3
EQA02-10BV3
EQA02-11DV3
EQA02-14BV3
ERD28-04S
HZ10EB3
HZ12EB2
HZ12A2L
HZ15EB3
HZ4.3EB1
HZ4.3EB2
HZ4.3EB3
HZ5.6EB2
HZ6.2EB1
HZ6.2EB2
HZ6.2EB3
HZ7.5EB2
HZ7.5EB3

HZ9.1EB2
RD10EB3
RD12EB1
RD12EB2
RD12EB3
RD15EB3
RD3.0EB1
RD3.9EB2
RD3.9EB2
RD4.3EB1
RD4.3EB2
RD4.3EB3
RD4.7EL1
RD4.7EL2
RD4.7EL3
RD5.6EB2
RD6.2EB1
RD6.2EB2
RD6.2EB3
RD7.5EB3
RD9.1EB1
RD9.1EB2
RD9.1EB3

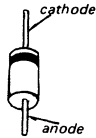

1S2835



1S2837



1S2838



1T25

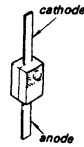

CR02AM-4

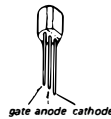

CR3CM-8

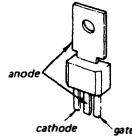

CTU-38R
CTU-38S

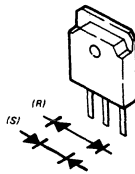

ESAC25-04C

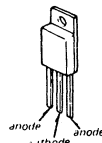

ESAC25-04N
ESAD25-04D

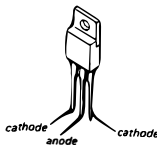

ESAC31-02D

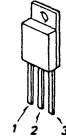

10E2
ERB81-004
GP08D
HZT33-02

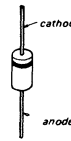

HZ12EB1
HZ12EB3
HZ3.0EB1
HZ3.0EB2
HZ3.9EB2
HZ9.1EB1
HZ9.1EB3

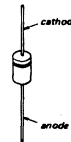

LT-9220H

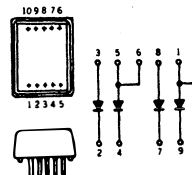

MC911



MC921

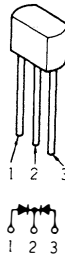

MC931



RB406NH

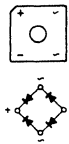

RD5.6M-B2



ERC24-04S
ERC24-06S
RH-1
RU-1A
SIB01-02



S3WB60Z

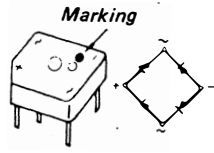

TLG124A
TLR124
TLY124
TLO124

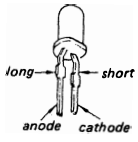

U05G
V11N

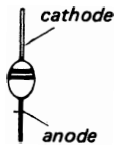

SECTION 6 EXPLODED VIEWS

NOTE:

- Items with no part number and no description are not stocked because they are seldom required for routine service.
- The construction parts of an assembled part are indicated with a collation number in the remark column.

- Items marked " * " are not stocked since they are seldom required for routine service. Some delay should be anticipated when ordering these items.

The components identified by shading and mark \blacktriangle are critical for safety. Replace only with part number specified.

6-1. BEZEL

- :BVTT3x6 7-682-147-01
- :BVTT3x6 7-682-547-09
- ▲ :BVTT4x6 7-685-760-09

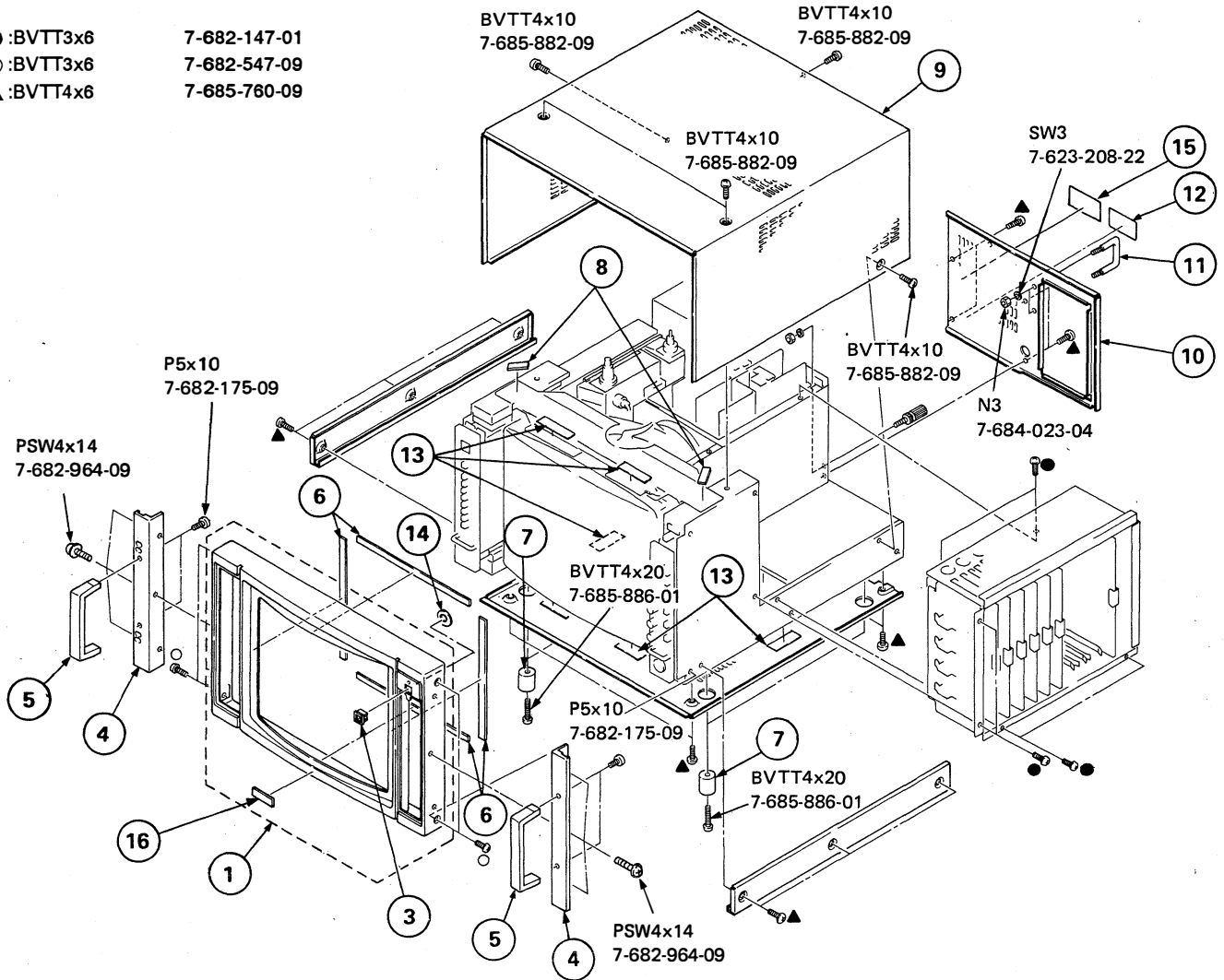

Ref. No.	Part No.	Description	Remark	Ref. No.	Part No.	Description	Remark
1	X-4379-403-1	BEZEL ASSY		11	*4-379-476-01	PROTECTOR, CONNECTOR	
3	4-379-423-01	ESCUTCHEON (A)		12	*4-379-486-01	LABEL, MODEL NUMBER (LARGE) (BVM-1410P ONLY)	
4	*2-378-214-01	BASE, HANDLE			*4-379-494-01	LABEL, MODEL NUMBER (LARGE) (BVM-1410PM ONLY)	
5	*4-337-212-11	HANDLE		13	4-864-324-11	SPACER	
6	4-308-878-XX	CUSHION, (A) PICTURE TUBE		14	4-309-378-00	SPACER	
7	3-642-656-01	FOOT		15	4-379-497-01	LABEL (S), PTB (BVM-1410P ONLY)	
8	9-911-840-XX	DAMPER, CASE (LOWER)		16	3-668-914-00	EMBLEM, SONY	
9	*4-379-461-01	CABINET					
10	*4-379-450-01	COVER, BACK					

6-2. PICTURE TUBE

●:BVTT3x6 7-682-147-01

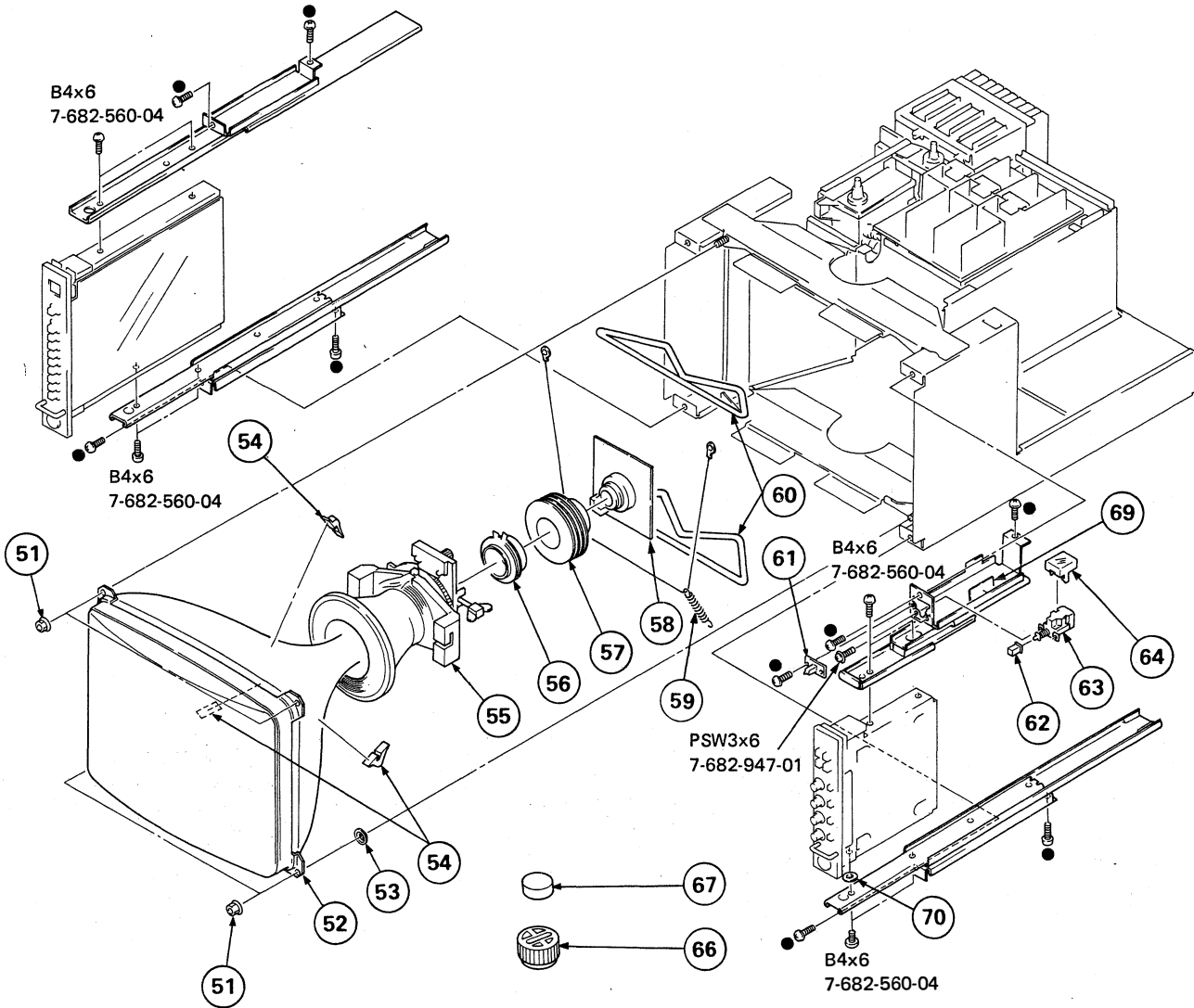

The components identified by shading and mark Δ are critical for safety. Replace only with part number specified.

Ref. No.	Part No.	Description	Remark	Ref. No.	Part No.	Description	Remark
51	4-306-034-00	FLANGE NUT, (B) 5MM		61	*1-617-893-11	Y BOARD	
52	Δ 8-738-052-05	PICTURE TUBE (M34JNR21X)		62	4-374-839-11	BUTTON (A)	
53	4-348-567-00	WASHER, CRT POSITION		63	Δ 1-570-052-12	SWITCH, PUSH (AC POWER) (1 KEY)	
54	3-703-961-01	SPACER, DY		64	4-373-038-01	COVER, SWITCH, POWER	
55	Δ 1-451-287-21	DEFLECTION YOKE (SY-135B)		66	1-452-094-00	MAGNET, ROTATABLE DISK; 15MM ϕ	
56	Δ 1-452-261-22	CRT NECK ASSY (362)		67	1-452-032-00	MAGNET, DISK; 10MM ϕ	
57	Δ 1-452-117-31	CRT NECK ASSY		69	*9-911-844-XX	CUSHION, CONTROL BUTTON	
58	*1-617-889-11	C BOARD		70	4-866-147-11	SPACER	
59	4-303-774-XX	SPRING					
60	Δ 1-426-263-11	COIL, DEMAGNETIZATION					

6-3. CHASSIS

- :BVTT3x6 7-682-147-01
- ▲ :BVTT4x6 7-685-760-09

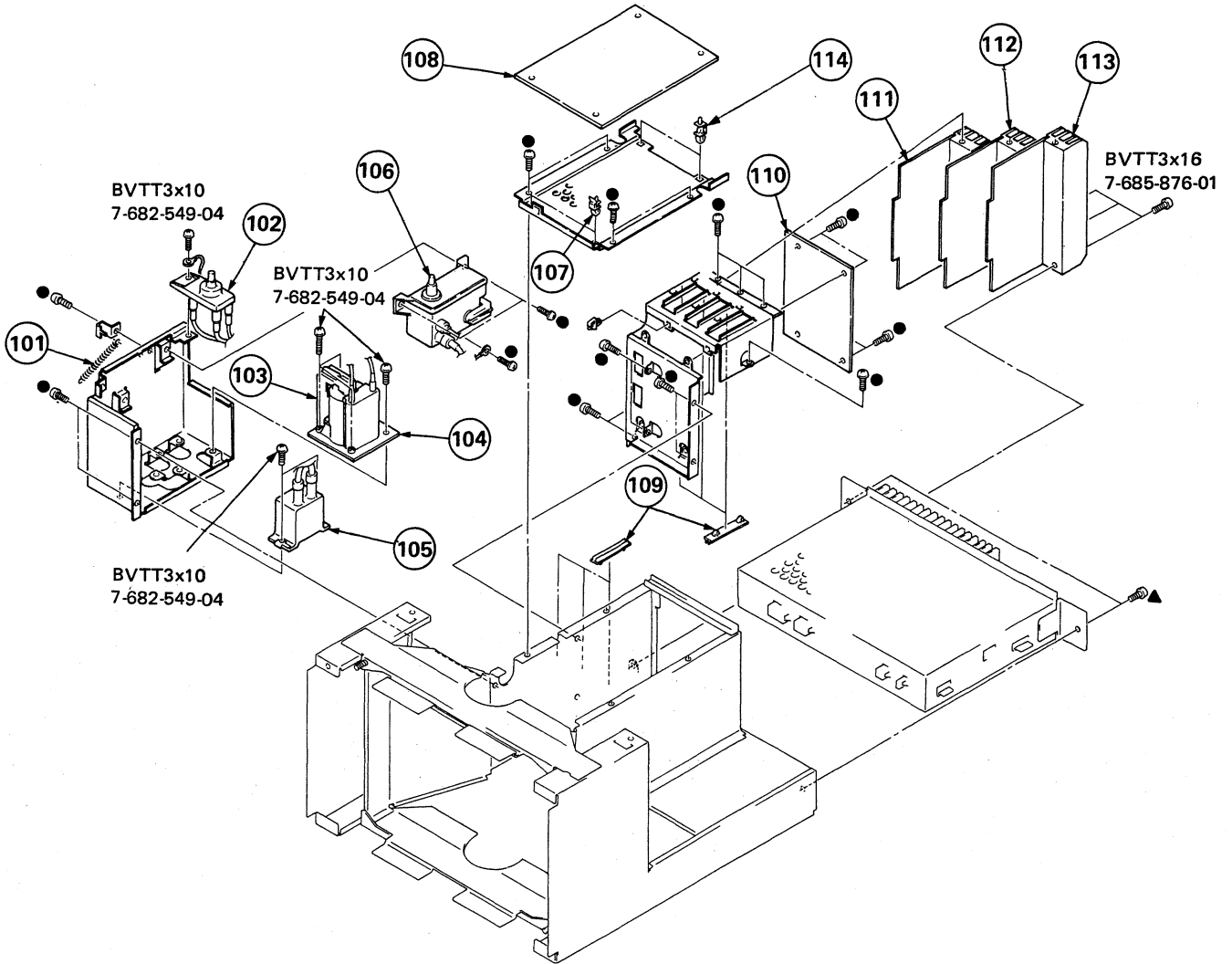

The components identified by shading and mark ▲ are critical for safety. Replace only with part number specified.

Ref. No.	Part No.	Description	Remark	Ref. No.	Part No.	Description	Remark
101	4-335-996-00	SPRING		108	*A-1135-362-A	BK BOARD, COMPLETE	
102	▲ 1-237-165-12	RESISTOR ASSY, HIGH-VOLTAGE		109	*3-680-613-01	SUPPORT, PC BOARD	
103	▲ 1-439-382-21	TRANSFORMER ASSY, FLYBACK		110	*1-617-898-11	TA BOARD	
104	*1-617-891-11	PB BOARD		111	*A-1345-596-A	EA BOARD, COMPLETE	
105	▲ 1-162-142-21	CAP BLOCK, HIGH VOLTAGE		112	*A-1345-597-A	EB BOARD, COMPLETE	
106	▲ 1-453-103-41	HIGH-VOLTAGE BLOCK		113	*A-1345-598-A	PA BOARD, COMPLETE	
107	*3-703-141-00	HOLDER, PCB		114	*4-353-620-02	HINGE, PC BOARD	

6-4. SIGNAL BLOCK

● :BVTT3x6 7-682-147-01

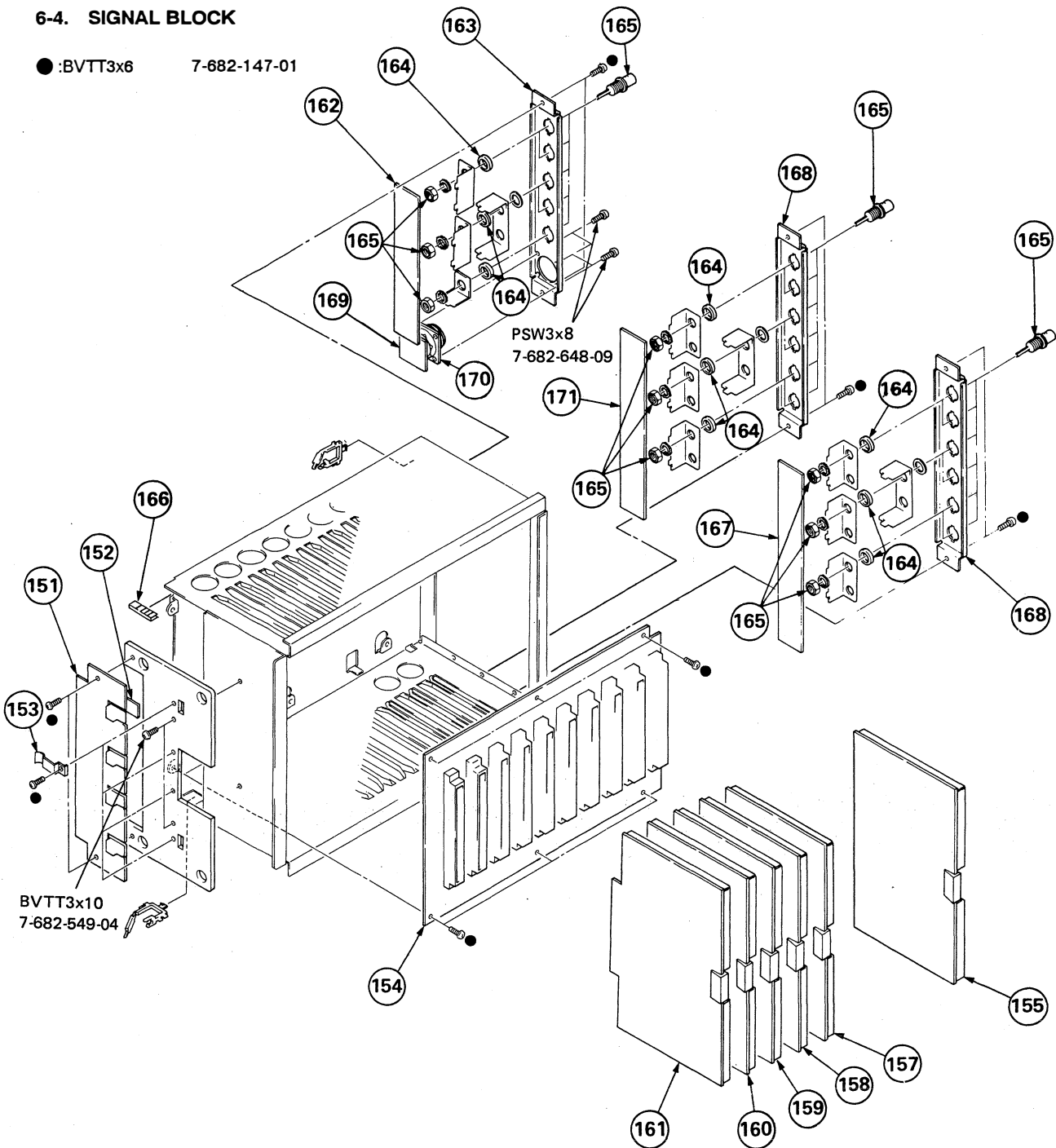

Ref. No.	Part No.	Description	Remark	Ref. No.	Part No.	Description	Remark
151	*1-617-885-11	GC BOARD		162	*1-617-897-11	W BOARD	
152	4-370-970-01	SPACER, TR		163	*4-379-440-01	PANEL (B), CONNECTOR	
153	*4-363-404-00	HOLDER, IC		164	*4-379-404-01	INSULATOR, BNC	
154	*1-617-899-11	TB BOARD		165	1-565-791-11	CONNECTOR, BNC 1P	
155	*A-1135-355-A	BA BOARD, COMPLETE		166	*4-911-234-01	EDGING	
157	*A-1135-391-A	BD BOARD, COMPLETE (BVM-1410P ONLY)		167	*1-617-895-11	QA BOARD	
	*A-1135-424-A	BM BOARD, COMPLETE (BVM-1410PM ONLY)		168	*4-379-439-01	PANEL (A), CONNECTOR	
158	*A-1135-358-A	BG BOARD, COMPLETE		169	*1-617-896-11	V BOARD	
159	*A-1135-359-A	BH BOARD, COMPLETE		170	1-563-265-11	CONNECTOR, MULTIPLE 10P	
160	*A-1135-360-A	BI BOARD, COMPLETE		171	*1-618-786-11	QB BOARD	
161	*A-1135-361-A	BJ BOARD, COMPLETE					

6-5. DRAWER BLOCK (RIGHT)

○ :BVTT3x6

7-682-547-09

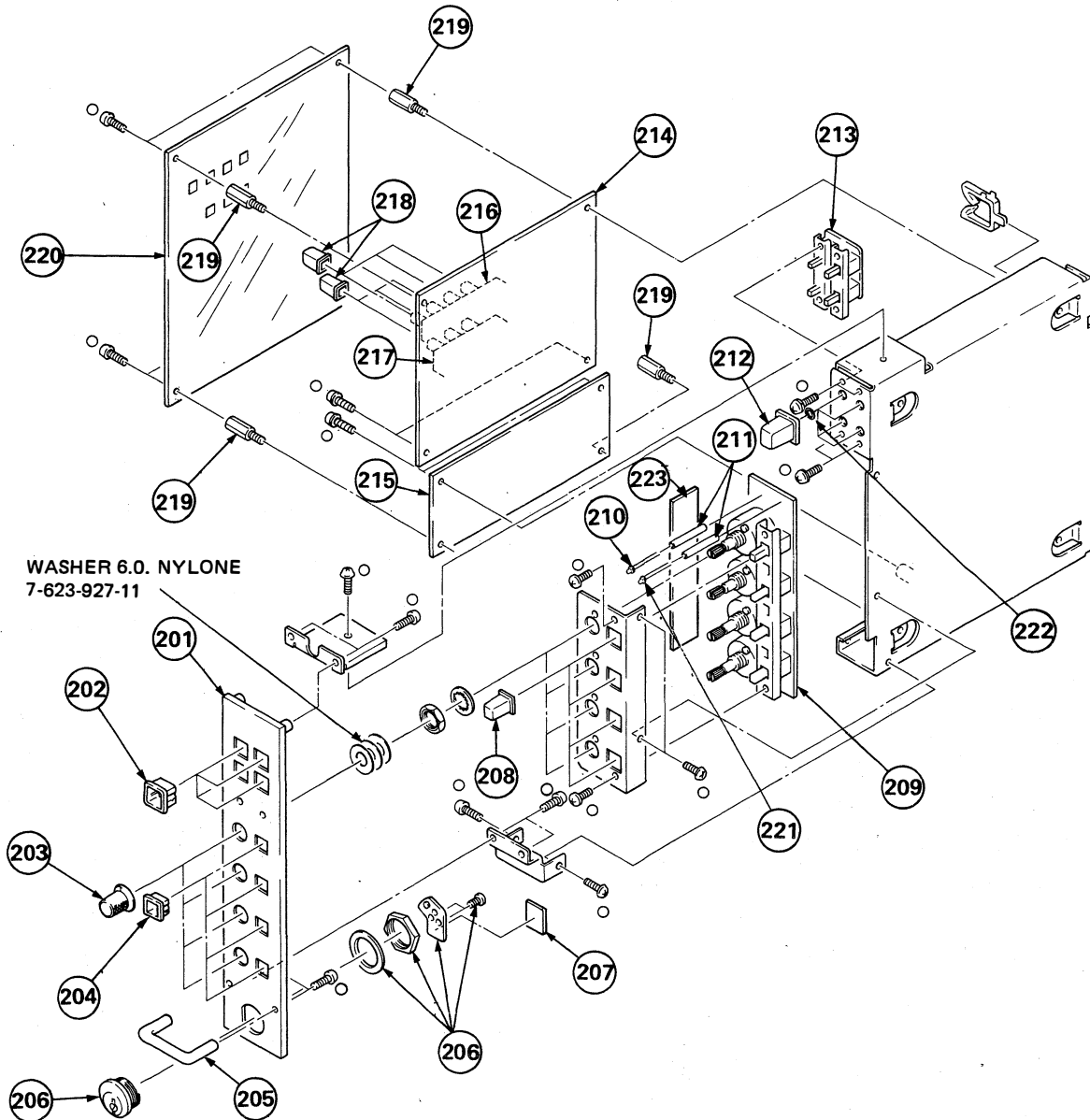

Ref. No.	Part No.	Description	Remark	Ref. No.	Part No.	Description	Remark
201	4-379-453-01	PANEL (RIGHT), CONTROL		211	*4-026-910-00	HOLDER, LED	
202	4-379-423-01	ESCUTCHEON (A)		212	4-374-839-01	BUTTON (A)	
203	X-3673-635-0	KNOB (1) ASSY, CONTROL		213	*1-617-887-11	HC BOARD	
204	4-379-424-01	ESCUTCHEON (B)		214	*1-617-886-11	HB BOARD	
205	4-379-421-01	HANDLE, DRAWER		215	*1-618-814-11	HE BOARD	
206	4-378-917-01	LOCK, CYLINDER		216	1-570-568-11	SWITCH, PUSH (4 KEY)	
207	4-337-209-11	PROTECTOR, SCRATCH		217	1-570-569-11	SWITCH, PUSH (3 KEY)	
208	4-379-422-01	BUTTON (B)		218	4-369-627-11	PUSH BUTTON	
209	*1-617-888-11	HD BOARD		219	*2-264-136-00	SUPPORT, SWITCH, PUSH BUTTON	
		(BVM-1410P ONLY Serial No. up to 2001396)		220	*4-379-475-01	COVER, HB PC BOARD	
		(BVM-1410PM ONLY Serial No. up to 2000020)		221	8-719-938-68	DIODE TLY124	
209	*1-627-681-11	HG BOARD		222	3-672-251-00	RING (M4), 0	
		(BVM-1410P ONLY Serial No. 2001397 and higher)		223	*1-627-682-11	HH BOARD	
		(BVM-1410PM ONLY Serial No. 2000021 and higher)				(BVM-1410P ONLY Serial No. 2001397 and higher)	
210	8-719-812-41	DIODE TLR124				(BVM-1410PM ONLY Serial No. 2000021 and higher)	

6-6. DRAWER BLOCK (LEFT)

- :BVTT3x6 7-682-147-01
- :BVTT3x6 7-682-547-09

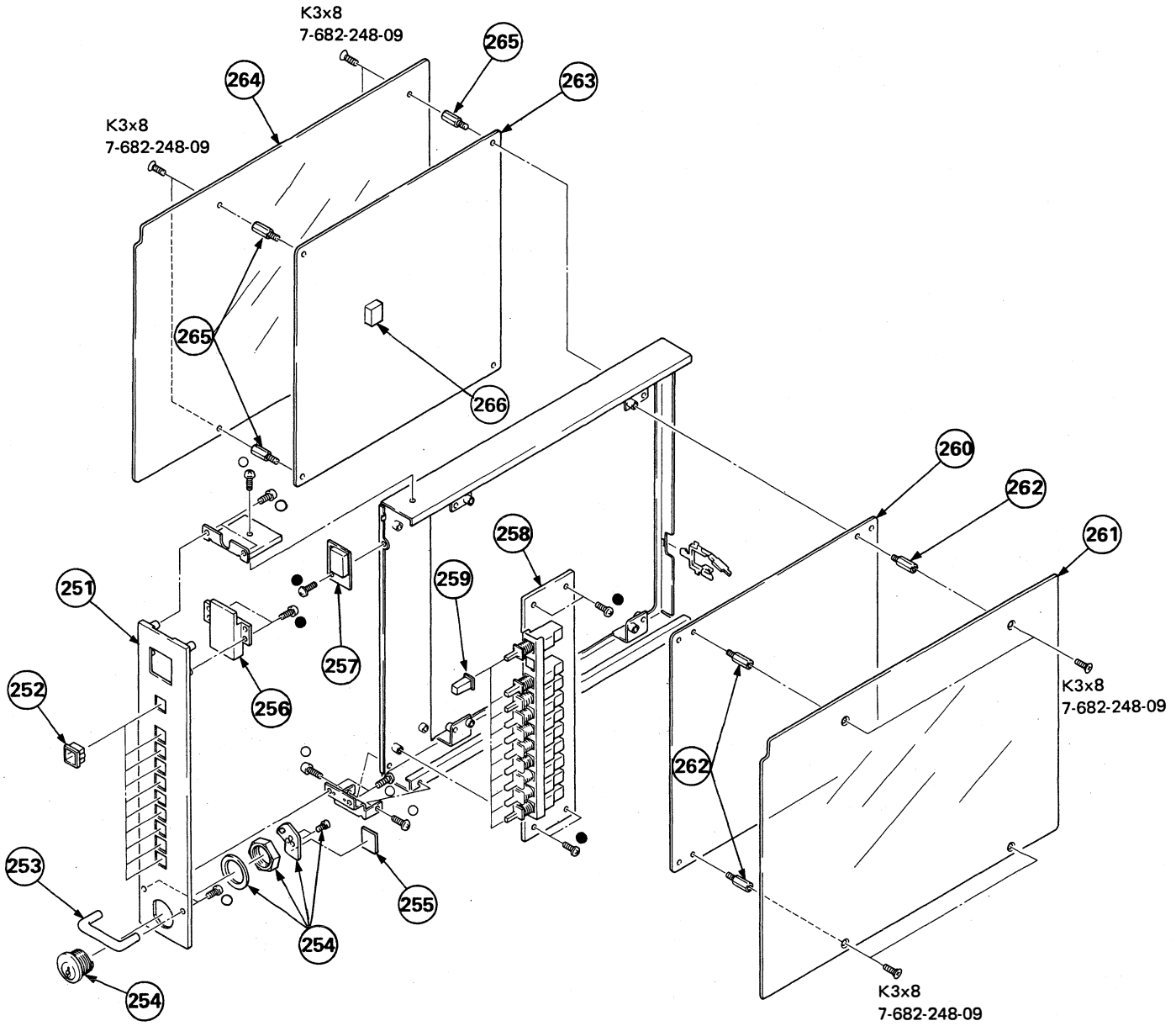

Ref. No.	Part No.	Description	Remark	Ref. No.	Part No.	Description	Remark
251	4-379-454-01	PANEL (LEFT), CONTROL		260	*A-1345-767-A	DA BOARD, COMPLETE	
252	4-379-423-01	ESCUTCHEON (A)		261	*4-379-481-01	COVER, DA PC BOARD	
253	4-379-421-01	HANDLE, DRAWER		262	*2-264-136-00	SUPPORT, SWITCH, PUSH BUTTON	
254	4-378-917-01	LOCK, CYLINDER		263	*A-1345-768-A	DB BOARD, COMPLETE	
255	4-337-209-11	PROTECTOR, SCRATCH		264	*4-379-474-01	COVER, DB PC BOARD	
256	4-379-418-01	COVER, LAMP		265	*4-886-542-00	SUPPORT	
257	*1-617-892-11	X BOARD		266	9-911-841-XX	CUSHION	
258	*1-617-890-11	HA BOARD					
259	4-374-839-01	BUTTON (A)					

6-7. POWER BLOCK

●:BVTT3x6

7-682-147-01

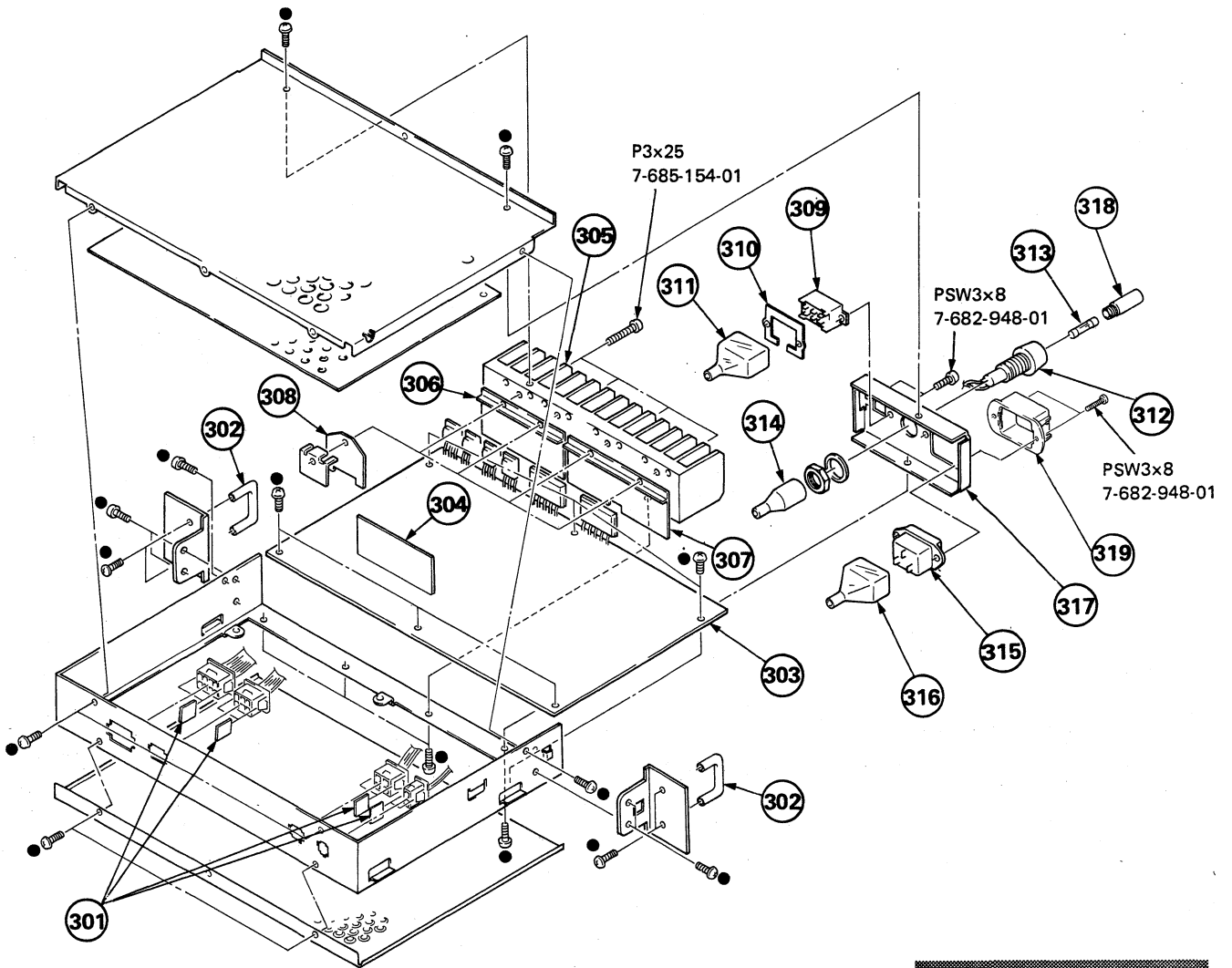

The components identified by shading and mark Δ are critical for safety. Replace only with part number specified.

Ref. No.	Part No.	Description	Remark	Ref. No.	Part No.	Description	Remark
301	3-675-469-00	SPACER, SOLENOID		311	*4-371-879-02	COVER, AC SELECT	
302	4-379-421-01	HANDLE, DRAWER		312	1-533-167-21	HOLDER, FUSE	
303	*A-1316-056-A	GA BOARD, COMPLETE (BVM-1410P ONLY)		313	Δ 1-532-203-11	FUSE, TIME-LAG 2A/250V (BVM-1410P ONLY)	
304	*A-1316-048-A	GA BOARD, COMPLETE (BVM-1410PM ONLY)			Δ 1-532-746-11	FUSE, GLASS TUBE 4A/125V (BVM-1410PM ONLY)	
305	*1-617-884-11	GB BOARD		314	*4-393-031-01	COVER, FUSE HOLDER	
	*4-347-706-00	HEAT SINK (TR)		315	Δ 1-580-375-11	3P INLET	
306	4-379-410-01	SPACER (G2), POLISHING		316	*4-601-466-11	COVER, 3P INLET	
307	4-379-403-01	SPACER (G1), POLISHING		317	*4-379-430-02	PANEL, POWER	
308	*4-379-408-01	INSULATOR (G3)		318	1-533-168-21	HOLDER, FUSE	
309	Δ 1-570-173-22	SWITCH, SLIDE (VOLTAGE CHANGE)		319	2-990-241-01	HOLDER (A), PLUG	
310	*4-379-409-01	NUT, PLATE					

SECTION 7 ELECTRICAL PARTS LIST

BA

NOTE:

The components identified by shading and mark Δ are critical for safety. Replace only with part number specified.

• Items marked " * " are not stocked since they are seldom required for routine service. Some delay should be anticipated when ordering these items.

• All variable and adjustable resistors have characteristic curve B, unless otherwise noted.

RESISTORS

• All resistors are in ohms
• F : nonflammable

When indicating parts by reference number, please include the board name.

CAPACITORS

• MF : μ F, PF : $\mu\mu$ F • MMH : mH, UH : μ H

COILS

• The components identified by \boxtimes in this manual have been carefully factory-selected for each set in order to satisfy regulations regarding X-ray radiation. Should replacement be required, replace only with the value originally used.

Ref.No	Part No.	Description	Remark	Ref.No	Part No.	Description	Remark
	* A-1135-355-A	BA BOARD, COMPLETE *****		C72	1-101-004-00	CERAMIC	0.01MF 50V
	* 4-353-708-00	HOOK, FINGER		C73	1-101-004-00	CERAMIC	0.01MF 50V
	* 7-682-547-04	SCREW BVTT 3X6 (S)		C74	1-101-004-00	CERAMIC	0.01MF 50V
	* 8-729-119-78	TRANSISTOR 2SC2785-HFE		C75	1-101-004-00	CERAMIC	0.01MF 50V
		<u>CONNECTOR</u>		C76	1-101-004-00	CERAMIC	0.01MF 50V
BA1	* 1-566-054-11	PIN, CONNECTOR 2P		C77	1-101-004-00	CERAMIC	0.01MF 50V
BA2	* 1-566-054-11	PIN, CONNECTOR 2P		C101	1-102-038-00	CERAMIC	0.001MF 500V
BA3	* 1-566-054-11	PIN, CONNECTOR 2P		C102	1-123-356-00	ELECT	10MF 20% 16V
BA4	* 1-566-054-11	PIN, CONNECTOR 2P		C103	1-102-951-00	CERAMIC	15PF 5% 50V
BA5	* 1-566-054-11	PIN, CONNECTOR 2P		C104	1-123-379-00	ELECT	0.47MF 20% 50V
BA6	* 1-566-054-11	PIN, CONNECTOR 2P		C201	1-102-038-00	CERAMIC	0.001MF 500V
		<u>CAPACITOR</u>		C202	1-123-356-00	ELECT	10MF 20% 16V
C1	1-123-332-00	ELECT	47MF 20% 16V	C203	1-102-951-00	CERAMIC	15PF 5% 50V
C2	1-123-332-00	ELECT	47MF 20% 16V	C204	1-123-379-00	ELECT	0.47MF 20% 50V
C3	1-123-332-00	ELECT	47MF 20% 16V	C301	1-102-038-00	CERAMIC	0.001MF 500V
C4	1-123-356-00	ELECT	10MF 20% 16V	C302	1-123-356-00	ELECT	10MF 20% 16V
C5	1-123-332-00	ELECT	47MF 20% 16V	C303	1-102-965-00	CERAMIC	39PF 5% 50V
C6	1-123-332-00	ELECT	47MF 20% 16V	C304	1-123-379-00	ELECT	0.47MF 20% 50V
C7	1-123-332-00	ELECT	47MF 20% 16V	C305	1-102-947-00	CERAMIC	10PF 0.5PF 50V
C8	1-123-332-00	ELECT	47MF 20% 16V	C306	1-102-942-00	CERAMIC	5PF 1PF 50V
C9	1-101-004-00	CERAMIC	0.01MF 50V	C401	1-102-038-00	CERAMIC	0.001MF 500V
C10	1-101-004-00	CERAMIC	0.01MF 50V	C402	1-123-356-00	ELECT	10MF 20% 16V
C11	1-124-119-00	ELECT	330MF 20% 16V	C403	1-102-951-00	CERAMIC	15PF 5% 50V
C12	1-123-356-00	ELECT	10MF 20% 16V	C404	1-123-379-00	ELECT	0.47MF 20% 50V
C13	1-123-356-00	ELECT	10MF 20% 16V	C501	1-102-038-00	CERAMIC	0.001MF 500V
C14	1-123-356-00	ELECT	10MF 20% 16V	C502	1-123-356-00	ELECT	10MF 20% 16V
C15	1-123-356-00	ELECT	10MF 20% 16V	C503	1-102-951-00	CERAMIC	15PF 5% 50V
C16	1-123-356-00	ELECT	10MF 20% 16V	C504	1-123-379-00	ELECT	0.47MF 20% 50V
C17	1-123-356-00	ELECT	10MF 20% 16V	C601	1-102-038-00	CERAMIC	0.001MF 500V
C18	1-123-356-00	ELECT	10MF 20% 16V	C602	1-123-356-00	ELECT	10MF 20% 16V
C19	1-123-356-00	ELECT	10MF 20% 16V	C603	1-102-951-00	CERAMIC	15PF 5% 50V
C20	1-101-004-00	CERAMIC	0.01MF 50V	C604	1-123-379-00	ELECT	0.47MF 20% 50V
C21	1-101-006-00	CERAMIC	0.047MF 50V	C701	1-102-976-00	CERAMIC	180PF 5% 50V
C31	1-101-004-00	CERAMIC	0.01MF 50V	C702	1-102-947-00	CERAMIC	10PF 0.5PF 50V
C32	1-123-356-00	ELECT	10MF 20% 16V	C703	1-123-356-00	ELECT	10MF 20% 16V
C33	1-123-356-00	ELECT	10MF 20% 16V	C704	1-123-332-00	ELECT	47MF 20% 16V
C34	1-123-356-00	ELECT	10MF 20% 16V	C705	1-136-153-00	FILM	0.01MF 5% 50V
C35	1-123-356-00	ELECT	10MF 20% 16V	C706	1-123-380-00	ELECT	1MF 20% 50V
C36	1-123-356-00	ELECT	10MF 20% 16V	C707	1-123-369-00	ELECT	4.7MF 20% 25V
C37	1-123-356-00	ELECT	10MF 20% 16V	C708	1-123-356-00	ELECT	10MF 20% 16V
C38	1-123-356-00	ELECT	10MF 20% 16V	C709	1-102-973-00	CERAMIC	100PF 5% 50V
C39	1-101-004-00	CERAMIC	0.01MF 50V	C710	1-130-481-00	MYLAR	0.0068MF 5% 50V
C51	1-124-119-00	ELECT	330MF 20% 16V	C711	1-136-155-00	FILM	0.015MF 5% 50V
C52	1-123-356-00	ELECT	10MF 20% 16V	C712	1-130-471-00	MYLAR	0.001MF 5% 50V
C53	1-123-356-00	ELECT	10MF 20% 16V	C713	1-123-380-00	ELECT	1MF 20% 50V
C54	1-123-356-00	ELECT	10MF 20% 16V	C714	1-102-973-00	CERAMIC	100PF 5% 50V
C55	1-123-356-00	ELECT	10MF 20% 16V	C715	1-101-361-00	CERAMIC	150PF 5% 50V
C56	1-123-356-00	ELECT	10MF 20% 16V	C716	1-136-153-00	FILM	0.01MF 5% 50V
C57	1-123-356-00	ELECT	10MF 20% 16V	C717	1-102-973-00	CERAMIC	100PF 5% 50V
C71	1-101-004-00	CERAMIC	0.01MF 50V			<u>TRIMMER</u>	
				CV101	1-141-179-12	CAP, VAR, TRIMMER	
				CV102	1-141-260-00	TRIMAR, CERAMIC	
				CV201	1-141-179-12	CAP, VAR, TRIMMER	
				CV202	1-141-260-00	TRIMAR, CERAMIC	

BA

Ref.No	Part No.	Description	Remark	Ref.No	Part No.	Description	Remark
CV401	1-141-179-12	CAP, VAR, TRIMMER		Q702	8-729-119-78	TRANSISTOR 2SC2785-HFE	
CV402	1-141-260-00	TRIMAR, CERAMIC		Q703	8-729-119-78	TRANSISTOR 2SC2785-HFE	
CV501	1-141-179-12	CAP, VAR, TRIMMER		Q704	8-729-119-78	TRANSISTOR 2SC2785-HFE	
CV502	1-141-260-00	TRIMAR, CERAMIC		Q705	8-729-119-78	TRANSISTOR 2SC2785-HFE	
CV601	1-141-179-12	CAP, VAR, TRIMMER		Q706	8-729-119-76	TRANSISTOR 2SA1175-HFE	
CV602	1-141-260-00	TRIMAR, CERAMIC		Q707	8-729-119-78	TRANSISTOR 2SC2785-HFE	
<u>DIODE</u>				Q708	8-729-119-76	TRANSISTOR 2SA1175-HFE	
D1	8-719-109-63	DIODE RD3.0ES-B2		Q709	8-729-119-78	TRANSISTOR 2SC2785-HFE	
D2	8-719-000-06	DIODE MC921		Q710	8-729-119-76	TRANSISTOR 2SA1175-HFE	
D4	8-719-000-04	DIODE MC911		Q711	8-729-119-76	TRANSISTOR 2SA1175-HFE	
D701	8-719-911-19	DIODE 1SS119		Q712	8-729-119-76	TRANSISTOR 2SA1175-HFE	
D702	8-719-109-75	DIODE RD4.3ES-B2		Q713	8-729-119-76	TRANSISTOR 2SA1175-HFE	
D703	8-719-911-19	DIODE 1SS119		Q714	8-729-119-78	TRANSISTOR 2SC2785-HFE	
D704	8-719-911-19	DIODE 1SS119		Q715	8-729-800-10	TRANSISTOR 2SC3068	
D705	8-719-911-19	DIODE 1SS119		Q716	8-729-119-78	TRANSISTOR 2SC2785-HFE	
D706	8-719-911-19	DIODE 1SS119		Q717	8-729-119-76	TRANSISTOR 2SA1175-HFE	
D707	8-719-911-19	DIODE 1SS119		<u>RESISTOR</u>			
D708	8-719-911-19	DIODE 1SS119		R1	1-249-405-11	CARBON	100 5% 1/4W
D709	8-719-911-19	DIODE 1SS119		R2	1-249-405-11	CARBON	100 5% 1/4W
D710	8-719-911-19	DIODE 1SS119		R3	1-249-405-11	CARBON	100 5% 1/4W
<u>IC</u>				R4	1-249-437-11	CARBON	47K 5% 1/4W
IC1	8-759-208-94	IC CX-894		R5	1-249-405-11	CARBON	100 5% 1/4W
IC2	8-759-208-94	IC CX-894		R6	1-249-432-11	CARBON	18K 5% 1/4W
IC3	8-759-040-53	IC MCI4053BCP		R7	1-249-434-11	CARBON	27K 5% 1/4W
<u>TRANSISTOR</u>				R8	1-249-422-11	CARBON	2.7K 5% 1/4W
Q1	8-729-900-89	TRANSISTOR DTC144ES		R9	1-249-405-11	CARBON	100 5% 1/4W
Q2	8-729-384-48	TRANSISTOR 2SA844-E		R10	1-249-405-11	CARBON	100 5% 1/4W
Q3	8-729-900-89	TRANSISTOR DTC144ES		R11	1-249-433-11	CARBON	22K 5% 1/4W
Q4	8-729-900-89	TRANSISTOR DTC144ES		R12	1-249-405-11	CARBON	100 5% 1/4W
Q5	8-729-900-89	TRANSISTOR DTC144ES		R13	1-249-437-11	CARBON	47K 5% 1/4W
Q6	8-729-900-65	TRANSISTOR DTA144ES		R14	1-249-429-11	CARBON	10K 5% 1/4W
Q101	8-729-266-82	TRANSISTOR 2SC2668-O		R101	1-249-417-11	CARBON	1K 5% 1/4W
Q102	8-729-266-82	TRANSISTOR 2SC2668-O		R102	1-249-418-11	CARBON	1.2K 5% 1/4W
Q103	8-729-266-82	TRANSISTOR 2SC2668-O		R103	1-249-425-11	CARBON	4.7K 5% 1/4W
Q104	8-729-384-48	TRANSISTOR 2SA844-E		R104	1-249-405-11	CARBON	100 5% 1/4W
Q105	8-729-266-82	TRANSISTOR 2SC2668-O		R105	1-215-437-00	METAL	4.7K 1% 1/6W
Q201	8-729-266-82	TRANSISTOR 2SC2668-O		R106	1-249-430-11	CARBON	12K 5% 1/4W
Q202	8-729-266-82	TRANSISTOR 2SC2668-O		R107	1-249-433-11	CARBON	22K 5% 1/4W
Q203	8-729-266-82	TRANSISTOR 2SC2668-O		R108	1-215-427-00	METAL	1.8K 1% 1/6W
Q204	8-729-384-48	TRANSISTOR 2SA844-E		R109	1-215-415-00	METAL	560 1% 1/6W
Q205	8-729-266-82	TRANSISTOR 2SC2668-O		R110	1-249-405-11	CARBON	100 5% 1/4W
Q301	8-729-266-82	TRANSISTOR 2SC2668-O		R111	1-215-431-00	METAL	2.7K 1% 1/6W
Q302	8-729-266-82	TRANSISTOR 2SC2668-O		R112	1-249-421-11	CARBON	2.2K 5% 1/4W
Q303	8-729-266-82	TRANSISTOR 2SC2668-O		R113	1-249-393-11	CARBON	10 5% 1/4W
Q304	8-729-384-48	TRANSISTOR 2SA844-D		R201	1-249-417-11	CARBON	1K 5% 1/4W
Q305	8-729-266-82	TRANSISTOR 2SC2668-O		R202	1-249-418-11	CARBON	1.2K 5% 1/4W
Q401	8-729-266-82	TRANSISTOR 2SC2668-O		R203	1-249-425-11	CARBON	4.7K 5% 1/4W
Q402	8-729-266-82	TRANSISTOR 2SC2668-O		R204	1-249-405-11	CARBON	100 5% 1/4W
Q403	8-729-266-82	TRANSISTOR 2SC2668-O		R205	1-215-437-00	METAL	4.7K 1% 1/6W
Q404	8-729-384-48	TRANSISTOR 2SA844-E		R206	1-249-430-11	CARBON	12K 5% 1/4W
Q405	8-729-266-82	TRANSISTOR 2SC2668-O		R207	1-249-433-11	CARBON	22K 5% 1/4W
Q501	8-729-266-82	TRANSISTOR 2SC2668-O		R208	1-215-427-00	METAL	1.8K 1% 1/6W
Q502	8-729-266-82	TRANSISTOR 2SC2668-O		R209	1-215-415-00	METAL	560 1% 1/6W
Q503	8-729-266-82	TRANSISTOR 2SC2668-O		R210	1-249-405-11	CARBON	100 5% 1/4W
Q504	8-729-384-48	TRANSISTOR 2SA844-E		R211	1-215-431-00	METAL	2.7K 1% 1/6W
Q505	8-729-266-82	TRANSISTOR 2SC2668-O		R212	1-249-421-11	CARBON	2.2K 5% 1/4W
Q601	8-729-266-82	TRANSISTOR 2SC2668-O		R213	1-249-393-11	CARBON	10 5% 1/4W
Q602	8-729-266-82	TRANSISTOR 2SC2668-O		R301	1-249-417-11	CARBON	1K 5% 1/4W
Q603	8-729-266-82	TRANSISTOR 2SC2668-O		R302	1-249-418-11	CARBON	1.2K 5% 1/4W
Q604	8-729-384-48	TRANSISTOR 2SA844-E		R303	1-249-426-11	CARBON	5.6K 5% 1/4W
Q605	8-729-266-82	TRANSISTOR 2SC2668-O		R304	1-249-405-11	CARBON	100 5% 1/4W
Q701	8-729-119-76	TRANSISTOR 2SA1175-HFE		R305	1-249-426-11	CARBON	5.6K 5% 1/4W
				R306	1-249-430-11	CARBON	12K 5% 1/4W
				R307	1-249-432-11	CARBON	18K 5% 1/4W

7. ELECTRICAL PARTS LIST

Ref.No	Part No.	Description	Remark		
R308	1-249-421-11	CARBON	2.2K	5%	1/4W
R309	1-249-417-11	CARBON	1K	5%	1/4W
R310	1-249-405-11	CARBON	100	5%	1/4W
R311	1-249-417-11	CARBON	1K	5%	1/4W
R312	1-249-421-11	CARBON	2.2K	5%	1/4W
R313	1-249-393-11	CARBON	10	5%	1/4W
R401	1-249-417-11	CARBON	1K	5%	1/4W
R402	1-249-418-11	CARBON	1.2K	5%	1/4W
R403	1-249-425-11	CARBON	4.7K	5%	1/4W
R404	1-249-405-11	CARBON	100	5%	1/4W
R405	1-215-437-00	METAL	4.7K	1%	1/6W
R406	1-249-430-11	CARBON	12K	5%	1/4W
R407	1-249-433-11	CARBON	22K	5%	1/4W
R408	1-215-427-00	METAL	1.8K	1%	1/6W
R409	1-215-415-00	METAL	560	1%	1/6W
R410	1-249-405-11	CARBON	100	5%	1/4W
R411	1-215-431-00	METAL	2.7K	1%	1/6W
R412	1-249-421-11	CARBON	2.2K	5%	1/4W
R413	1-249-393-11	CARBON	10	5%	1/4W
R501	1-249-417-11	CARBON	1K	5%	1/4W
R502	1-249-418-11	CARBON	1.2K	5%	1/4W
R503	1-249-425-11	CARBON	4.7K	5%	1/4W
R504	1-249-405-11	CARBON	100	5%	1/4W
R505	1-215-437-00	METAL	4.7K	1%	1/6W
R506	1-249-430-11	CARBON	12K	5%	1/4W
R507	1-249-433-11	CARBON	22K	5%	1/4W
R508	1-215-427-00	METAL	1.8K	1%	1/6W
R509	1-215-415-00	METAL	560	1%	1/6W
R510	1-249-405-11	CARBON	100	5%	1/4W
R511	1-215-431-00	METAL	2.7K	1%	1/6W
R512	1-249-421-11	CARBON	2.2K	5%	1/4W
R513	1-249-393-11	CARBON	10	5%	1/4W
R601	1-249-417-11	CARBON	1K	5%	1/4W
R602	1-249-418-11	CARBON	1.2K	5%	1/4W
R603	1-249-425-11	CARBON	4.7K	5%	1/4W
R604	1-249-405-11	CARBON	100	5%	1/4W
R605	1-215-437-00	METAL	4.7K	1%	1/6W
R606	1-249-430-11	CARBON	12K	5%	1/4W
R607	1-249-433-11	CARBON	22K	5%	1/4W
R608	1-215-427-00	METAL	1.8K	1%	1/6W
R609	1-215-415-00	METAL	560	1%	1/6W
R610	1-249-405-11	CARBON	100	5%	1/4W
R611	1-215-431-00	METAL	2.7K	1%	1/6W
R612	1-249-421-11	CARBON	2.2K	5%	1/4W
R613	1-249-393-11	CARBON	10	5%	1/4W
R701	1-249-433-11	CARBON	22K	5%	1/4W
R702	1-249-438-11	CARBON	56K	5%	1/4W
R703	1-249-417-11	CARBON	1K	5%	1/4W
R704	1-249-417-11	CARBON	1K	5%	1/4W
R705	1-249-424-11	CARBON	3.9K	5%	1/4W
R706	1-249-417-11	CARBON	1K	5%	1/4W
R707	1-249-429-11	CARBON	10K	5%	1/4W
R708	1-249-421-11	CARBON	2.2K	5%	1/4W
R709	1-249-419-11	CARBON	1.5K	5%	1/4W
R710	1-249-418-11	CARBON	1.2K	5%	1/4W
R711	1-249-434-11	CARBON	27K	5%	1/4W
R712	1-249-433-11	CARBON	22K	5%	1/4W
R713	1-249-422-11	CARBON	2.7K	5%	1/4W
R714	1-249-427-11	CARBON	6.8K	5%	1/4W
R715	1-249-433-11	CARBON	22K	5%	1/4W
R716	1-249-422-11	CARBON	2.7K	5%	1/4W
R717	1-249-425-11	CARBON	4.7K	5%	1/4W
R718	1-249-410-11	CARBON	270	5%	1/4W
R719	1-249-414-11	CARBON	560	5%	1/4W
R720	1-247-850-11	CARBON	6.2K	5%	1/4W

Ref.No	Part No.	Description	Remark		
R721	1-249-438-11	CARBON	56K	5%	1/4W
R722	1-249-441-11	CARBON	100K	5%	1/4W
R723	1-249-437-11	CARBON	47K	5%	1/4W
R724	1-249-429-11	CARBON	10K	5%	1/4W
R725	1-249-438-11	CARBON	56K	5%	1/4W
R726	1-247-895-00	CARBON	470K	5%	1/4W
R727	1-249-425-11	CARBON	4.7K	5%	1/4W
R728	1-249-435-11	CARBON	33K	5%	1/4W
R729	1-249-423-11	CARBON	3.3K	5%	1/4W
R730	1-249-421-11	CARBON	2.2K	5%	1/4W
R731	1-249-422-11	CARBON	2.7K	5%	1/4W
R732	1-249-422-11	CARBON	2.7K	5%	1/4W
R733	1-249-421-11	CARBON	2.2K	5%	1/4W
R734	1-249-421-11	CARBON	2.2K	5%	1/4W
R735	1-249-421-11	CARBON	2.2K	5%	1/4W
R736	1-249-425-11	CARBON	4.7K	5%	1/4W
R737	1-249-405-11	CARBON	100	5%	1/4W
R738	1-249-441-11	CARBON	100K	5%	1/4W
R739	1-249-433-11	CARBON	22K	5%	1/4W
R740	1-249-417-11	CARBON	1K	5%	1/4W
R741	1-202-473-00	SOLID	5.6M	5%	1/4W

VARIABLE RESISTOR

RV101	1-237-514-21	RES, ADJ, CERMET 500
RV201	1-237-514-21	RES, ADJ, CERMET 500
RV401	1-237-514-21	RES, ADJ, CERMET 500
RV501	1-237-514-21	RES, ADJ, CERMET 500
RV601	1-237-514-21	RES, ADJ, CERMET 500

*A-1135-391-A BD BOARD, COMPLETE (BVM-1410P ONLY)

 *A-1135-424-A BM BOARD, COMPLETE (BVM-1410PM ONLY)

*4-353-708-00 HOOK, FINGER
 7-682-950-01 SCREW PSW 3X12
 7-682-547-04 SCREW BVTT 3X6 (S)

CAPACITOR

C1	1-102-858-00	CERAMIC (BVM-1410P ONLY)	10PF	0.5PF	50V
C1	1-102-951-00	CERAMIC (BVM-1410PM ONLY)	15PF	5%	50V
C2	1-102-858-00	CERAMIC (BVM-1410P ONLY)	10PF	0.5PF	50V
C2	1-102-951-00	CERAMIC (BVM-1410PM ONLY)	15PF	5%	50V
C3	1-102-963-00	CERAMIC (BVM-1410P ONLY)	33PF	5%	50V
C4	1-101-880-00	CERAMIC (BVM-1410P ONLY)	47PF	5%	50V
C4	1-101-361-00	CERAMIC (BVM-1410PM ONLY)	39PF	5%	50V
C6	1-101-888-00	CERAMIC (BVM-1410P ONLY)	68PF	5%	50V
C6	1-101-884-00	CERAMIC (BVM-1410PM ONLY)	56PF	5%	50V
C7	1-102-963-00	CERAMIC (BVM-1410P ONLY)	33PF	5%	50V
C7	1-101-361-00	CERAMIC (BVM-1410PM ONLY)	39PF	5%	50V
C8	1-102-943-00	CERAMIC (BVM-1410P ONLY)	6PF	0.5PF	50V
C8	1-102-935-00	CERAMIC (BVM-1410PM ONLY)	2PF	0.25PF	50V
C9	1-123-356-00	ELECT	10MF	20%	16V
C10	1-123-356-00	ELECT	10MF	20%	16V

Ref.No	Part No.	Description	Remark
D2	8-719-911-19	DIODE 1SS119	
D4	8-719-109-63	DIODE RD30ES-B2	
D5	8-719-110-13	DIODE RD9.1ES-B2	
D6	8-719-911-19	DIODE 1SS119	
D10	8-719-920-95	DIODE 1T25-0	
D11	8-719-911-19	DIODE 1SS119	
D12	8-719-110-31	DIODE RD12ES-B2	
D13	8-719-110-31	DIODE RD12ES-B2	
D15	8-719-911-19	DIODE 1SS119 (BVM-1410PM ONLY)	
D16	8-719-911-19	DIODE 1SS119	
D201	8-719-911-19	DIODE 1SS119	
D202	8-719-911-19	DIODE 1SS119	
<u>IC</u>			
IC1	8-759-204-21	IC TA7193P	
IC2	8-759-800-81	IC LA7016	
IC3	8-759-246-15	IC TL8608AP	
	1-526-654-00	SOCKET, IC (DP) 16P (IC3)	
IC4	8-759-246-15	IC TL8608AP	
	1-526-654-00	SOCKET, IC (DP) 16P (IC4)	
IC5	8-759-040-53	IC MC14053BCP	
IC6	8-759-800-81	IC LA7016	
IC7	8-759-945-58	IC RC4558P	
IC8	8-759-945-58	IC RC4558P	
<u>COIL</u>			
L1	1-408-533-00	COIL, VARIABLE	
L2	1-408-532-00	COIL, VARIABLE	
L3	1-408-514-00	COIL (VARIABLE) (BVM-1410P ONLY)	
L3	1-408-533-00	COIL, VARIABLE (BVM-1410PM ONLY)	
L4	1-408-421-00	INDUCTOR 100UH	
L5	1-408-429-00	INDUCTOR 470UH	
L6	1-408-429-00	INDUCTOR 470UH	
L8	1-408-421-00	INDUCTOR 100UH	
L101	1-408-421-00	INDUCTOR 100UH	
L102	1-408-421-00	INDUCTOR 100UH	
<u>TRANSISTOR</u>			
Q1	8-729-119-78	TRANSISTOR 2SC2785-HFE	
Q2	8-729-119-78	TRANSISTOR 2SC2785-HFE	
Q3	8-729-119-78	TRANSISTOR 2SC2785-HFE	
Q4	8-729-800-10	TRANSISTOR 2SC3068	
Q5	8-729-800-10	TRANSISTOR 2SC3068	
Q6	8-729-384-48	TRANSISTOR 2SA844-E	
Q7	8-729-119-78	TRANSISTOR 2SC2785-HFE	
Q8	8-729-384-48	TRANSISTOR 2SA844-E	
Q9	8-729-119-78	TRANSISTOR 2SC2785-HFE	
Q10	8-729-119-76	TRANSISTOR 2SA1175-HFE (BVM-1410P ONLY)	
Q10	8-729-384-48	TRANSISTOR 2SA844-E (BVM-1410PM ONLY)	
Q11	8-729-119-76	TRANSISTOR 2SA1175-HFE (BVM-1410P ONLY)	
Q11	8-729-384-48	TRANSISTOR 2SA844-E (BVM-1410PM ONLY)	
Q12	8-729-119-78	TRANSISTOR 2SC2785-HFE	
Q13	8-729-119-78	TRANSISTOR 2SC2785-HFE	
Q14	8-729-119-78	TRANSISTOR 2SC2785-HFE	
Q15	8-729-119-78	TRANSISTOR 2SC2785-HFE	
Q16	8-729-119-78	TRANSISTOR 2SC2785-HFE	
Q17	8-729-119-78	TRANSISTOR 2SC2785-HFE	
Q18	8-729-600-19	TRANSISTOR 2SK381-A	
Q20	8-729-119-76	TRANSISTOR 2SA1175-HFE (BVM-1410P ONLY)	
Q20	8-729-384-48	TRANSISTOR 2SA844-E (BVM-1410PM ONLY)	
Q21	8-729-119-78	TRANSISTOR 2SC2785-HFE	
Q22	8-729-119-78	TRANSISTOR 2SC2785-HFE	
Q23	8-729-384-48	TRANSISTOR 2SA844-E	
Q24	8-729-119-78	TRANSISTOR 2SC2785-HFE	
Q25	8-729-800-10	TRANSISTOR 2SC3068	
Q26	8-729-600-19	TRANSISTOR 2SK381-A	

Ref.No	Part No.	Description	Remark
Q28	8-729-119-76	TRANSISTOR 2SA1175-HFE (BVM-1410P ONLY)	
Q28	8-729-384-48	TRANSISTOR 2SA844-E (BVM-1410PM ONLY)	
Q29	8-729-119-78	TRANSISTOR 2SC2785-HFE	
Q30	8-729-119-78	TRANSISTOR 2SC2785-HFE	
Q31	8-729-384-48	TRANSISTOR 2SA844-E	
Q32	8-729-119-78	TRANSISTOR 2SC2785-HFE	
Q33	8-729-800-10	TRANSISTOR 2SC3068	
Q34	8-729-119-78	TRANSISTOR 2SC2785-HFE	
Q35	8-729-119-78	TRANSISTOR 2SC2785-HFE	
Q36	8-729-119-78	TRANSISTOR 2SC2785-HFE	
Q38	8-729-119-78	TRANSISTOR 2SC2785-HFE	
Q101	8-729-140-97	TRANSISTOR 2SB734-34	
Q102	8-729-320-62	TRANSISTOR 2SD789-34 (BVM-1410P ONLY)	
Q102	8-729-378-93	TRANSISTOR 2SD789-5 (BVM-1410PM ONLY)	
Q103	8-729-900-63	TRANSISTOR DTA124ES	
Q104	8-729-900-63	TRANSISTOR DTA124ES	
<u>RESISTOR</u>			
R1	1-249-428-11	CARBON 8.2K 5% 1/4W	
R2	1-249-429-11	CARBON 10K 5% 1/4W	
R3	1-249-422-11	CARBON 2.7K 5% 1/4W	
R4	1-215-425-00	METAL 1.5K 1% 1/6W	
		(BVM-1410P ONLY)	
R4	1-215-421-00	METAL 1K 1% 1/6W	
		(BVM-1410PM ONLY)	
R5	1-215-395-00	METAL 82 1% 1/6W	
		(BVM-1410P ONLY)	
R5	1-215-398-00	METAL 110 1% 1/6W	
		(BVM-1410PM ONLY)	
R6	1-215-421-00	METAL 1K 1% 1/6W	
R7	1-215-421-00	METAL 1K 1% 1/6W	
R8	1-215-423-00	METAL 1.2K 1% 1/6W	
		(BVM-1410P ONLY)	
R8	1-215-427-00	METAL 1.8K 1% 1/6W	
		(BVM-1410PM ONLY)	
R9	1-215-421-00	METAL 1K 1% 1/6W	
R10	1-215-421-00	METAL 1K 1% 1/6W	
R11	1-215-391-00	METAL 56 1% 1/6W	
		(BVM-1410P ONLY)	
R11	1-215-400-00	METAL 130 1% 1/6W	
		(BVM-1410PM ONLY)	
R12	1-215-427-00	METAL 1.8K 1% 1/6W	
		(BVM-1410P ONLY)	
R12	1-215-429-00	METAL 2.2K 1% 1/6W	
		(BVM-1410PM ONLY)	
R13	1-249-425-11	CARBON 4.7K 5% 1/4W	
R14	1-249-429-11	CARBON 10K 5% 1/4W	
R15	1-249-429-11	CARBON 10K 5% 1/4W	
R17	1-249-433-11	CARBON 22K 5% 1/4W	
R18	1-215-425-00	METAL 1.5K 1% 1/6W	
R19	1-215-425-00	METAL 1.5K 1% 1/6W	
R20	1-215-425-00	METAL 1.5K 1% 1/6W	
R21	1-215-425-00	METAL 1.5K 1% 1/6W	
R22	1-249-405-11	CARBON 100 5% 1/4W	
R23	1-215-441-00	METAL 6.8K 1% 1/6W	
		(BVM-1410P ONLY)	
R23	1-215-439-00	METAL 5.6K 1% 1/6W	
		(BVM-1410PM ONLY)	
R24	1-215-469-00	METAL 100K 1% 1/6W	
R25	1-249-427-11	CARBON 6.8K 5% 1/4W	
		(BVM-1410P ONLY)	
R25	1-249-425-11	CARBON 4.7K 5% 1/4W	
		(BVM-1410PM ONLY)	
R26	1-249-415-11	CARBON 680 5% 1/4W	
		(BVM-1410P ONLY)	
R26	1-249-418-11	CARBON 1.2K 5% 1/4W	
		(BVM-1410PM ONLY)	
R27	1-249-415-11	CARBON 680 5% 1/4W	



Ref.No	Part No.	Description	Remark
R28	1-249-420-11	CARBON 1.8K (BVM-1410P ONLY)	5% 1/4W
R28	1-249-423-11	CARBON 3.3K (BVM-1410PM ONLY)	5% 1/4W
R29	1-249-422-11	CARBON 2.7K	5% 1/4W
R30	1-249-405-11	CARBON 100	5% 1/4W
R31	1-247-903-00	CARBON 1M	5% 1/4W
R32	1-249-429-11	CARBON 10K	5% 1/4W
R34	1-215-407-00	METAL 270 (BVM-1410P ONLY)	1% 1/6W
R34	1-215-417-00	METAL 680 (BVM-1410PM ONLY)	1% 1/6W
R35	1-215-407-00	METAL 270 (BVM-1410P ONLY)	1% 1/6W
R35	1-215-417-00	METAL 680 (BVM-1410PM ONLY)	1% 1/6W
R36	1-215-413-00	METAL 470	1% 1/6W
R37	1-215-443-00	METAL 8.2K	1% 1/6W
R38	1-249-441-11	CARBON 100K	5% 1/4W
R39	1-215-425-00	METAL 1.5K (BVM-1410P ONLY)	1% 1/6W
R39	1-215-429-00	METAL 2.2K (BVM-1410PM ONLY)	1% 1/6W
R40	1-215-421-00	METAL 1K (BVM-1410P ONLY)	1% 1/6W
R40	1-249-417-11	CARBON 1K (BVM-1410PM ONLY)	5% 1/4W
R41	1-215-429-00	METAL 2.2K (BVM-1410P ONLY)	1% 1/6W
R41	1-249-421-11	CARBON 2.2K (BVM-1410PM ONLY)	5% 1/4W
R42	1-215-445-00	METAL 10K (BVM-1410P ONLY)	1% 1/6W
R42	1-249-429-11	CARBON 10K (BVM-1410PM ONLY)	5% 1/4W
R43	1-215-421-00	METAL 1K (BVM-1410P ONLY)	1% 1/6W
R43	1-249-417-11	CARBON 1K (BVM-1410PM ONLY)	5% 1/4W
R44	1-249-433-11	CARBON 22K	5% 1/4W
R45	1-249-429-11	CARBON 10K	5% 1/4W
R46	1-249-429-11	CARBON 10K	5% 1/4W
R47	1-249-441-11	CARBON 100K	5% 1/4W
R48	1-249-425-11	CARBON 4.7K	5% 1/4W
R54	1-249-422-11	CARBON 2.7K	5% 1/4W
R55	1-215-418-00	METAL 750 (BVM-1410P ONLY)	1% 1/6W
R55	1-215-420-00	METAL 910 (BVM-1410PM ONLY)	1% 1/6W
R56	1-215-420-00	METAL 910	1% 1/6W
R57	1-249-415-11	CARBON 680	5% 1/4W
R58	1-249-422-11	CARBON 2.7K	5% 1/4W
R59	1-249-422-11	CARBON 2.7K	5% 1/4W
R60	1-215-418-00	METAL 750 (BVM-1410P ONLY)	1% 1/6W
R60	1-215-420-00	METAL 910 (BVM-1410PM ONLY)	1% 1/6W
R61	1-215-420-00	METAL 910	1% 1/6W
R62	1-249-415-11	CARBON 680	5% 1/4W
R63	1-249-422-11	CARBON 2.7K	5% 1/4W
R64	1-215-477-00	METAL 220K (BVM-1410P ONLY)	1% 1/6W
R64	1-249-417-11	CARBON 1K (BVM-1410PM ONLY)	5% 1/4W
R65	1-215-435-00	METAL 3.9K (BVM-1410P ONLY)	1% 1/6W
R65	1-215-429-00	METAL 2.2K (BVM-1410PM ONLY)	1% 1/6W
R66	1-249-405-11	CARBON 100	5% 1/4W

Ref.No	Part No.	Description	Remark
R70	1-247-903-00	CARBON 1M	5% 1/4W
R71	1-249-429-11	CARBON 10K	5% 1/4W
R72	1-249-429-11	CARBON 10K	5% 1/4W
R73	1-249-429-11	CARBON 10K	5% 1/4W
R74	1-249-417-11	CARBON 1K	5% 1/4W
R75	1-249-427-11	CARBON 6.8K	5% 1/4W
R76	1-249-427-11	CARBON 6.8K	5% 1/4W
R77	1-249-425-11	CARBON 4.7K	5% 1/4W
R78	1-215-424-00	METAL 1.3K	1% 1/6W
R79	1-215-419-00	METAL 820	1% 1/6W
R80	1-215-425-00	METAL 1.5K	1% 1/6W
R81	1-249-422-11	CARBON 2.7K	5% 1/4W
R82	1-249-425-11	CARBON 4.7K	5% 1/4W
R83	1-249-435-11	CARBON 33K	5% 1/4W
R84	1-249-435-11	CARBON 33K	5% 1/4W
R85	1-247-903-00	CARBON 1M	5% 1/4W
R86	1-249-429-11	CARBON 10K	5% 1/4W
R87	1-249-429-11	CARBON 10K	5% 1/4W
R88	1-249-429-11	CARBON 10K	5% 1/4W
R89	1-249-417-11	CARBON 1K	5% 1/4W
R90	1-249-427-11	CARBON 6.8K	5% 1/4W
R91	1-249-427-11	CARBON 6.8K	5% 1/4W
R92	1-249-425-11	CARBON 4.7K	5% 1/4W
R93	1-215-424-00	METAL 1.3K	1% 1/6W
R94	1-215-419-00	METAL 820	1% 1/6W
R95	1-215-425-00	METAL 1.5K	1% 1/6W
R96	1-249-422-11	CARBON 2.7K	5% 1/4W
R97	1-249-425-11	CARBON 4.7K	5% 1/4W
R98	1-249-435-11	CARBON 33K	5% 1/4W
R99	1-249-435-11	CARBON 33K	5% 1/4W
R100	1-215-438-00	METAL 5.1K	1% 1/6W
R101	1-215-438-00	METAL 5.1K	1% 1/6W
R102	1-215-438-00	METAL 5.1K	1% 1/6W
R103	1-215-438-00	METAL 5.1K	1% 1/6W
R104	1-249-437-11	CARBON 47K	5% 1/4W
R105	1-249-438-11	CARBON 56K	5% 1/4W
R106	1-249-417-11	CARBON 1K	5% 1/4W
R107	1-249-417-11	CARBON 1K	5% 1/4W
R108	1-249-417-11	CARBON 1K	5% 1/4W
R109	1-249-417-11	CARBON 1K	5% 1/4W
R110	1-249-417-11	CARBON 1K	5% 1/4W
R115	1-215-438-00	METAL 5.1K (BVM-1410P ONLY)	1% 1/6W
R115	1-215-429-00	METAL 2.2K (BVM-1410PM ONLY)	1% 1/6W
R116	1-215-438-00	METAL 5.1K (BVM-1410P ONLY)	1% 1/6W
R116	1-215-429-00	METAL 2.2K (BVM-1410PM ONLY)	1% 1/6W
R120	1-249-429-11	CARBON 10K	5% 1/4W
R121	1-249-429-11	CARBON 10K	5% 1/4W
R130	1-215-477-00	METAL 220K (BVM-1410P ONLY)	1% 1/6W
R130	1-215-485-00	METAL 470K (BVM-1410PM ONLY)	1% 1/6W
R150	1-249-441-11	CARBON 100K	5% 1/4W
R201	1-249-423-11	CARBON 3.3K	5% 1/4W
R202	1-249-423-11	CARBON 3.3K	5% 1/4W
R203	1-249-422-11	CARBON 2.7K	5% 1/4W
R204	1-249-423-11	CARBON 3.3K	5% 1/4W
R220	1-249-441-11	CARBON 100K	5% 1/4W
R221	1-249-433-11	CARBON 22K	5% 1/4W
R222	1-249-433-11	CARBON 22K	5% 1/4W
R250	1-215-415-00	METAL 560	1% 1/6W
R251	1-215-415-00	METAL 560	1% 1/6W
R252	1-215-421-00	METAL 1K	1% 1/6W

ELECTRICAL PARTS LIST

Ref.No	Part No.	Description	Remark		
R254	1-249-429-11	CARBON	10K	5%	1/4W
R255	1-249-441-11	CARBON	100K	5%	1/4W
R259	1-215-421-00	METAL	1K	1%	1/6W
R301	1-215-469-00	METAL	100K	1%	1/6W
R302	1-215-491-00	METAL	820K	1%	1/6W
R303	1-249-418-11	CARBON	1.2K	5%	1/4W
R305	1-249-431-11	CARBON	15K	5%	1/4W
R306	1-249-428-11	CARBON	8.2K	5%	1/4W
R307	1-249-417-11	CARBON	1K	5%	1/4W
R308	1-249-417-11	CARBON	1K	5%	1/4W
R310	1-249-422-11	CARBON	2.7K	5%	1/4W
R314	1-215-417-00	METAL	680	1%	1/6W
R315	1-249-422-11	CARBON	2.7K	5%	1/4W
R316	1-249-413-11	CARBON	470	5%	1/4W
R317	1-249-413-11	CARBON	470	5%	1/4W
R320	1-215-472-00	METAL	130K	1%	1/6W
		(BVM-1410P ONLY)			
R320	1-215-482-00	METAL	360K	1%	1/6W
		(BVM-1410PM ONLY)			
R353	1-249-432-11	CARBON	18K	5%	1/4W
R354	1-249-432-11	CARBON	18K	5%	1/4W
R400	1-215-429-00	METAL	2.2K	1%	1/6W
<u>VARIABLE RESISTOR</u>					
RV1	1-237-515-21	RES, ADJ, CERMET	1K		
RV2	1-237-499-21	RES, ADJ, CERMET	500		
RV3	1-237-501-21	RES, ADJ, CERMET	2K		
RV4	1-237-501-21	RES, ADJ, CERMET	2K		
RV5	1-237-517-21	RES, ADJ, CERMET	5K		
RV6	1-237-517-21	RES, ADJ, CERMET	5K		
RV7	1-237-504-21	RES, ADJ, CERMET	20K		
RV8	1-237-504-21	RES, ADJ, CERMET	20K		
RV9	1-237-517-21	RES, ADJ, CERMET	5K		
RV10	1-237-517-21	RES, ADJ, CERMET	5K		
<u>THERMISTOR</u>					
TH1	1-800-202-XX	THERMISTOR S-10K	(BVM-1410PM ONLY)		
<u>CRYSTAL</u>					
X1	1-567-504-11	OSCILLATOR, CRYSTAL	(BVM-1410P ONLY)		
X1	1-527-794-00	VIBRATOR, CRYSTAL	(BVM-1410PM ONLY)		
X2	1-567-409-11	VIBRATOR, CRYSTAL	(BVM-1410P ONLY)		
X2	1-567-416-11	VIBRATOR, CRYSTAL	(BVM-1410PM ONLY)		

*A-1135-358-A BG BOARD, COMPLETE

*4-353-708-00 HOOK, FINGER
7-682-547-04 SCREW BVTT 3X6 (S)

CAPACITOR

C1	1-123-332-00	ELECT	47MF	20%	16V
C2	1-123-332-00	ELECT	47MF	20%	16V
C3	1-123-356-00	ELECT	10MF	20%	16V
C4	1-123-332-00	ELECT	47MF	20%	16V
C7	1-101-004-00	CERAMIC	0.01MF		50V
C8	1-101-004-00	CERAMIC	0.01MF		50V
C9	1-101-004-00	CERAMIC	0.01MF		50V
C10	1-102-935-00	CERAMIC	2PF	0.25PF	50V
C12	1-101-004-00	CERAMIC	0.01MF		50V
C15	1-102-965-00	CERAMIC	39PF	5%	50V
C16	1-101-004-00	CERAMIC	0.01MF		50V
C22	1-101-004-00	CERAMIC	0.01MF		50V
C25	1-102-965-00	CERAMIC	39PF	5%	50V
C26	1-101-004-00	CERAMIC	0.01MF		50V

Ref.No	Part No.	Description	Remark		
C32	1-101-004-00	CERAMIC	0.01MF		50V
C33	1-136-165-00	FILM	0.1MF	5%	50V
C34	1-136-165-00	FILM	0.1MF	5%	50V
C35	1-136-165-00	FILM	0.1MF	5%	50V
C41	1-102-942-00	CERAMIC	5PF	1PF	50V
C42	1-102-947-00	CERAMIC	10PF	0.5PF	50V
C44	1-102-936-00	CERAMIC	3PF	0.25PF	50V
C45	1-102-947-00	CERAMIC	10PF	0.5PF	50V
C47	1-123-356-00	ELECT	10MF	20%	16V
C51	1-102-942-00	CERAMIC	5PF	0.5PF	50V
C52	1-102-942-00	CERAMIC	5PF	0.5PF	50V
C53	1-123-356-00	ELECT	10MF	20%	25V
C54	1-101-004-00	CERAMIC	0.01MF		50V
C55	1-102-976-00	CERAMIC	180PF	5%	50V
C56	1-102-976-00	CERAMIC	180PF	5%	50V
C101	1-124-034-51	ELECT	33MF	20%	16V
C102	1-124-034-51	ELECT	33MF	20%	16V
C103	1-124-034-51	ELECT	33MF	20%	16V
C105	1-124-122-11	ELECT	100MF	20%	16V
C106	1-124-034-51	ELECT	33MF	20%	16V
C111	1-123-356-00	ELECT	10MF	20%	16V
C112	1-101-004-00	CERAMIC	0.01MF		50V
C113	1-101-004-00	CERAMIC	0.01MF		50V
C114	1-101-004-00	CERAMIC	0.01MF		50V
C115	1-101-004-00	CERAMIC	0.01MF		50V
C116	1-101-004-00	CERAMIC	0.01MF		50V
C117	1-101-004-00	CERAMIC	0.01MF		50V
C131	1-124-034-51	ELECT	33MF	20%	16V
C132	1-124-034-51	ELECT	33MF	20%	16V
C133	1-124-034-51	ELECT	33MF	20%	16V
C135	1-124-122-11	ELECT	100MF	20%	16V
C136	1-124-034-51	ELECT	33MF	20%	16V
C141	1-101-004-00	CERAMIC	0.01MF		50V
C142	1-101-004-00	CERAMIC	0.01MF		50V
C143	1-101-004-00	CERAMIC	0.01MF		50V
C144	1-101-004-00	CERAMIC	0.01MF		50V
C145	1-101-004-00	CERAMIC	0.01MF		50V
C146	1-101-004-00	CERAMIC	0.01MF		50V
C147	1-101-004-00	CERAMIC	0.01MF		50V
<u>TRIMMER</u>					
CV2	1-141-181-11	CAP,TRIMMER			
CV3	1-141-171-00	CAP,TRIMMER	20P		
<u>DIODE</u>					
D1	8-719-911-19	DIODE	1SS119		
D2	8-719-911-19	DIODE	1SS119		
D3	8-719-016-42	DIODE	MC932		
D4	8-719-016-42	DIODE	MC932		
D5	8-719-911-19	DIODE	1SS119		
D6	8-719-911-19	DIODE	1SS119		
D7	8-719-911-19	DIODE	1SS119		
D8	8-719-109-97	DIODE	RD6.2ES-B2		
D11	8-719-911-19	DIODE	1SS119		
D12	8-719-911-19	DIODE	1SS119		
D13	8-719-911-19	DIODE	1SS119		
D14	8-719-911-19	DIODE	1SS119		
D16	8-719-911-19	DIODE	1SS119		
D17	8-719-911-19	DIODE	1SS119		
<u>DELAY LINE</u>					
DL1	1-415-477-11	DELAY LINE			
DL2	1-415-458-11	DELAY LINE			
DL3	1-415-458-11	DELAY LINE			
DL4	1-415-458-11	DELAY LINE			

Ref.No	Part No.	Description	Remark
<u>IC</u>			
IC1	8-759-800-81	IC LA7016	
IC2	8-766-001-49	TRANSISTOR TX-429M	
IC3	8-759-945-58	IC RC4558P	
IC4	8-757-182-14	IC CX-718D-1	
IC5	8-759-040-53	IC MC14053BCP	
IC6	8-759-040-53	IC MC14053BCP	
IC7	8-759-990-82	IC TL082CP	
IC8	8-759-990-82	IC TL082CP	
IC9	8-759-990-82	IC TL082CP	
<u>COIL</u>			
L2	1-408-408-00	INDUCTOR 8.2UH	
L3	1-408-413-00	INDUCTOR 22UH	
L4	1-408-413-00	INDUCTOR 22UH	
<u>TRANSISTOR</u>			
Q1	8-729-119-78	TRANSISTOR 2SC2785-HFE	
Q5	8-729-119-78	TRANSISTOR 2SC2785-HFE	
Q7	8-729-119-78	TRANSISTOR 2SC2785-HFE	
Q8	8-729-119-78	TRANSISTOR 2SC2785-HFE	
Q9	8-729-119-78	TRANSISTOR 2SC2785-HFE	
Q10	8-729-384-48	TRANSISTOR 2SA844-E	
Q11	8-729-119-78	TRANSISTOR 2SC2785-HFE	
Q12	8-729-119-78	TRANSISTOR 2SC2785-HFE	
Q13	8-729-119-78	TRANSISTOR 2SC2785-HFE	
Q14	8-729-800-10	TRANSISTOR 2SC3068	
Q21	8-729-384-48	TRANSISTOR 2SA844-E	
Q22	8-729-119-78	TRANSISTOR 2SC2785-HFE	
Q23	8-729-119-78	TRANSISTOR 2SC2785-HFE	
Q24	8-729-600-19	TRANSISTOR 2SK381-A	
Q25	8-729-384-48	TRANSISTOR 2SA844-E	
Q26	8-729-119-78	TRANSISTOR 2SC2785-HFE	
Q27	8-729-119-78	TRANSISTOR 2SC2785-HFE	
Q28	8-729-600-19	TRANSISTOR 2SK381-A	
Q29	8-729-119-78	TRANSISTOR 2SC2785-HFE	
Q30	8-729-119-78	TRANSISTOR 2SC2785-HFE	
Q31	8-729-384-48	TRANSISTOR 2SA844-E	
Q32	8-729-119-78	TRANSISTOR 2SC2785-HFE	
Q33	8-729-119-78	TRANSISTOR 2SC2785-HFE	
Q34	8-729-600-19	TRANSISTOR 2SK381-A	
Q35	8-729-384-48	TRANSISTOR 2SA844-E	
Q36	8-729-119-78	TRANSISTOR 2SC2785-HFE	
Q37	8-729-119-78	TRANSISTOR 2SC2785-HFE	
Q38	8-729-600-19	TRANSISTOR 2SK381-A	
Q39	8-729-119-78	TRANSISTOR 2SC2785-HFE	
Q40	8-729-119-78	TRANSISTOR 2SC2785-HFE	
Q41	8-729-384-48	TRANSISTOR 2SA844-E	
Q42	8-729-384-48	TRANSISTOR 2SA844-E	
Q43	8-729-119-78	TRANSISTOR 2SC2785-HFE	
Q44	8-729-384-48	TRANSISTOR 2SA844-E	
Q45	8-729-119-78	TRANSISTOR 2SC2785-HFE	
Q49	8-729-119-78	TRANSISTOR 2SC2785-HFE	
Q50	8-729-119-78	TRANSISTOR 2SC2785-HFE	
Q51	8-729-900-63	TRANSISTOR DTA124ES	
Q52	8-729-900-63	TRANSISTOR DTA124ES	
Q53	8-729-900-63	TRANSISTOR DTA124ES	
Q54	8-729-119-78	TRANSISTOR 2SC2785-HFE	
Q55	8-729-600-19	TRANSISTOR 2SK381-A	
Q56	8-729-900-63	TRANSISTOR DTA124ES	
Q57	8-729-900-63	TRANSISTOR DTA124ES	
Q58	8-729-900-63	TRANSISTOR DTA124ES	
Q59	8-729-119-78	TRANSISTOR 2SC2785-HFE	
Q60	8-729-600-19	TRANSISTOR 2SK381-A	
Q71	8-729-384-48	TRANSISTOR 2SA844-E	

Ref.No	Part No.	Description	Remark
Q72	8-729-119-78	TRANSISTOR 2SC2785-HFE	
Q73	8-729-119-78	TRANSISTOR 2SC2785-HFE	
Q74	8-729-384-48	TRANSISTOR 2SA844-E	
Q75	8-729-800-10	TRANSISTOR 2SC3068	
Q76	8-729-900-63	TRANSISTOR DTA124ES	
Q77	8-729-900-63	TRANSISTOR DTA124ES	
Q78	8-729-900-89	TRANSISTOR DTC144ES	
Q81	8-729-384-48	TRANSISTOR 2SA844-E	
Q82	8-729-119-78	TRANSISTOR 2SC2785-HFE	
Q83	8-729-119-78	TRANSISTOR 2SC2785-HFE	
Q84	8-729-384-48	TRANSISTOR 2SA844-E	
Q85	8-729-800-10	TRANSISTOR 2SC3068	
<u>RESISTOR</u>			
R1	1-249-405-11	CARBON 100 5%	1/4W
R2	1-215-396-00	METAL 91 1%	1/6W
R3	1-215-431-00	METAL 2.7K 1%	1/6W
R4	1-249-419-11	CARBON 1.5K 5%	1/4W
R6	1-249-405-11	CARBON 100 5%	1/4W
R7	1-249-405-11	CARBON 100 5%	1/4W
R8	1-249-429-11	CARBON 10K 5%	1/4W
R10	1-247-830-11	CARBON 910 5%	1/4W
R11	1-249-417-11	CARBON 1K 5%	1/4W
R12	1-249-417-11	CARBON 1K 5%	1/4W
R13	1-215-462-00	METAL 51K 1%	1/6W
R14	1-249-426-11	CARBON 5.6K 5%	1/4W
R15	1-247-903-00	CARBON 1M 5%	1/4W
R16	1-215-477-00	METAL 220K 1%	1/6W
R17	1-249-429-11	CARBON 10K 5%	1/4W
R18	1-249-429-11	CARBON 10K 5%	1/4W
R19	1-249-417-11	CARBON 1K 5%	1/4W
R20	1-215-421-00	METAL 1K 1%	1/6W
R21	1-215-421-00	METAL 1K 1%	1/6W
R22	1-249-441-11	CARBON 100K 5%	1/4W
R23	1-215-409-00	METAL 330 1%	1/6W
R24	1-215-380-00	METAL 20 1%	1/6W
R25	1-215-380-00	METAL 20 1%	1/6W
R26	1-215-409-00	METAL 330 1%	1/6W
R27	1-249-429-11	CARBON 10K 5%	1/4W
R28	1-249-417-11	CARBON 1K 5%	1/4W
R29	1-215-418-00	METAL 750 1%	1/6W
R30	1-249-422-11	CARBON 2.7K 5%	1/4W
R31	1-249-405-11	CARBON 100 5%	1/4W
R32	1-249-420-11	CARBON 1.8K 5%	1/4W
R33	1-249-429-11	CARBON 10K 5%	1/4W
R34	1-249-428-11	CARBON 8.2K 5%	1/4W
R35	1-249-417-11	CARBON 1K 5%	1/4W
R36	1-249-422-11	CARBON 2.7K 5%	1/4W
R37	1-249-405-11	CARBON 100 5%	1/4W
R40	1-249-425-11	CARBON 4.7K 5%	1/4W
R41	1-249-422-11	CARBON 2.7K 5%	1/4W
R42	1-249-417-11	CARBON 1K 5%	1/4W
R43	1-249-417-11	CARBON 1K 5%	1/4W
R44	1-249-431-11	CARBON 15K 5%	1/4W
R45	1-249-423-11	CARBON 3.3K 5%	1/4W
R46	1-249-417-11	CARBON 1K 5%	1/4W
R47	1-249-423-11	CARBON 3.3K 5%	1/4W
R48	1-249-422-11	CARBON 2.7K 5%	1/4W
R49	1-249-405-11	CARBON 100 5%	1/4W
R50	1-249-422-11	CARBON 2.7K 5%	1/4W
R51	1-247-903-00	CARBON 1M 5%	1/4W
R52	1-247-866-11	CARBON 30K 5%	1/4W
R53	1-215-445-00	METAL 10K 1%	1/6W
R54	1-249-420-11	CARBON 1.8K 5%	1/4W
R55	1-249-422-11	CARBON 2.7K 5%	1/4W

ELECTRICAL PARTS LIST

Ref.No	Part No.	Description	Quantity	Unit	Remark
R56	1-249-405-11	CARBON	100	5%	1/4W
R57	1-249-422-11	CARBON	2.7K	5%	1/4W
R58	1-249-422-11	CARBON	2.7K	5%	1/4W
R59	1-249-422-11	CARBON	2.7K	5%	1/4W
R61	1-249-422-11	CARBON	2.7K	5%	1/4W
R62	1-249-417-11	CARBON	1K	5%	1/4W
R63	1-249-417-11	CARBON	1K	5%	1/4W
R64	1-249-431-11	CARBON	15K	5%	1/4W
R65	1-249-423-11	CARBON	3.3K	5%	1/4W
R66	1-249-417-11	CARBON	1K	5%	1/4W
R67	1-249-423-11	CARBON	3.3K	5%	1/4W
R68	1-249-422-11	CARBON	2.7K	5%	1/4W
R69	1-249-405-11	CARBON	100	5%	1/4W
R70	1-249-422-11	CARBON	2.7K	5%	1/4W
R71	1-247-903-00	CARBON	1M	5%	1/4W
R72	1-247-866-11	CARBON	30K	5%	1/4W
R73	1-215-445-00	METAL	10K	1%	1/6W
R74	1-249-420-11	CARBON	1.8K	5%	1/4W
R75	1-249-422-11	CARBON	2.7K	5%	1/4W
R76	1-249-405-11	CARBON	100	5%	1/4W
R77	1-249-422-11	CARBON	2.7K	5%	1/4W
R78	1-249-422-11	CARBON	2.7K	5%	1/4W
R79	1-249-422-11	CARBON	2.7K	5%	1/4W
R80	1-249-405-11	CARBON	100	5%	1/4W
R81	1-249-422-11	CARBON	2.7K	5%	1/4W
R82	1-247-903-00	CARBON	1M	5%	1/4W
R83	1-249-420-11	CARBON	1.8K	5%	1/4W
R84	1-249-405-11	CARBON	100	5%	1/4W
R85	1-247-866-11	CARBON	30K	5%	1/4W
R86	1-215-445-00	METAL	10K	1%	1/6W
R87	1-249-422-11	CARBON	2.7K	5%	1/4W
R88	1-215-430-00	METAL	2.4K	1%	1/6W
R89	1-215-443-00	METAL	8.2K	1%	1/6W
R90	1-249-430-11	CARBON	12K	5%	1/4W
R91	1-249-405-11	CARBON	100	5%	1/4W
R92	1-247-830-11	CARBON	910	5%	1/4W
R93	1-215-421-00	METAL	1K	1%	1/6W
R94	1-249-422-11	CARBON	2.7K	5%	1/4W
R98	1-249-422-11	CARBON	2.7K	5%	1/4W
R99	1-249-422-11	CARBON	2.7K	5%	1/4W
R101	1-249-432-11	CARBON	18K	5%	1/4W
R102	1-249-421-11	CARBON	2.2K	5%	1/4W
R103	1-249-421-11	CARBON	2.2K	5%	1/4W
R104	1-249-421-11	CARBON	2.2K	5%	1/4W
R105	1-249-433-11	CARBON	22K	5%	1/4W
R106	1-249-429-11	CARBON	10K	5%	1/4W
R107	1-249-429-11	CARBON	10K	5%	1/4W
R108	1-249-405-11	CARBON	100	5%	1/4W
R109	1-249-422-11	CARBON	2.7K	5%	1/4W
R110	1-249-405-11	CARBON	100	5%	1/4W
R111	1-249-435-11	CARBON	33K	5%	1/4W
R112	1-249-421-11	CARBON	2.2K	5%	1/4W
R113	1-249-421-11	CARBON	2.2K	5%	1/4W
R114	1-249-421-11	CARBON	2.2K	5%	1/4W
R115	1-249-433-11	CARBON	22K	5%	1/4W
R116	1-249-429-11	CARBON	10K	5%	1/4W
R117	1-249-429-11	CARBON	10K	5%	1/4W
R118	1-249-405-11	CARBON	100	5%	1/4W
R119	1-249-422-11	CARBON	2.7K	5%	1/4W
R120	1-249-405-11	CARBON	100	5%	1/4W
R161	1-215-438-00	METAL	5.1K	1%	1/6W
R162	1-249-431-11	CARBON	15K	5%	1/4W
R163	1-249-417-11	CARBON	1K	5%	1/4W
R164	1-215-435-00	METAL	3.9K	1%	1/6W
R165	1-249-422-11	CARBON	2.7K	5%	1/4W

Ref.No	Part No.	Description	Quantity	Unit	Remark
R166	1-249-422-11	CARBON	2.7K	5%	1/4W
R167	1-215-409-00	METAL	330	1%	1/6W
R168	1-215-411-00	METAL	390	1%	1/6W
R169	1-215-427-00	METAL	1.8K	1%	1/6W
R170	1-249-425-11	CARBON	4.7K	5%	1/4W
R171	1-215-436-00	METAL	4.3K	1%	1/6W
R172	1-249-431-11	CARBON	15K	5%	1/4W
R173	1-249-417-11	CARBON	1K	5%	1/4W
R174	1-215-435-00	METAL	3.9K	1%	1/6W
R175	1-249-422-11	CARBON	2.7K	5%	1/4W
R176	1-249-422-11	CARBON	2.7K	5%	1/4W
R177	1-215-409-00	METAL	330	1%	1/6W
R178	1-215-414-00	METAL	510	1%	1/6W
R179	1-215-422-00	METAL	1.1K	1%	1/6W
R180	1-249-425-11	CARBON	4.7K	5%	1/4W
R181	1-215-380-00	METAL	20	1%	1/6W
R182	1-215-380-00	METAL	20	1%	1/6W
R183	1-249-433-11	CARBON	22K	5%	1/4W
R184	1-249-425-11	CARBON	4.7K	5%	1/4W
R185	1-249-429-11	CARBON	10K	5%	1/4W
R201	1-249-437-11	CARBON	47K	5%	1/4W
R202	1-249-429-11	CARBON	10K	5%	1/4W
R203	1-249-435-11	CARBON	33K	5%	1/4W
R204	1-247-872-11	CARBON	51K	5%	1/4W

VARIABLE RESISTOR

RV1	1-237-514-21	RES, ADJ, CERMET 500
RV2	1-237-508-21	RES, ADJ, CERMET 500K
RV3	1-237-498-21	RES, ADJ, CERMET 200
RV4	1-237-500-21	RES, ADJ, CERMET 1K
RV5	1-237-500-21	RES, ADJ, CERMET 1K
RV11	1-237-519-21	RES, ADJ, CERMET 20K
RV12	1-237-519-21	RES, ADJ, CERMET 20K
RV13	1-237-519-21	RES, ADJ, CERMET 20K
RV14	1-237-519-21	RES, ADJ, CERMET 20K
RV15	1-237-519-21	RES, ADJ, CERMET 20K
RV16	1-237-519-21	RES, ADJ, CERMET 20K
RV21	1-237-517-21	RES, ADJ, CERMET 5K
RV22	1-237-517-21	RES, ADJ, CERMET 5K

SWITCH

S1	1-570-857-11	SWITCH, SLIDE
----	--------------	---------------

*A-1135-359-A BH BOARD, COMPLETE

*4-353-708-00 HOOK, FINGER
7-682-547-04 SCREW BVTT 3X6 (S)

CAPACITOR

C1	1-124-034-51	ELECT	33MF	20%	16V
C2	1-124-034-51	ELECT	33MF	20%	16V
C3	1-124-034-51	ELECT	33MF	20%	16V
C4	1-124-034-51	ELECT	33MF	20%	16V
C5	1-124-034-51	ELECT	33MF	20%	16V
C6	1-124-034-51	ELECT	33MF	20%	16V
C7	1-124-034-51	ELECT	33MF	20%	16V
C8	1-124-034-51	ELECT	33MF	20%	16V
C9	1-124-034-51	ELECT	33MF	20%	16V
C10	1-124-034-51	ELECT	33MF	20%	16V
C11	1-124-034-51	ELECT	33MF	20%	16V
C12	1-124-034-51	ELECT	33MF	20%	16V
C13	1-124-034-51	ELECT	33MF	20%	16V
C14	1-124-034-51	ELECT	33MF	20%	16V

Ref.No	Part No.	Description		Remark
C15	1-101-004-00	CERAMIC	0.01MF	50V
C16	1-101-004-00	CERAMIC	0.01MF	50V
C17	1-101-004-00	CERAMIC	0.01MF	50V
C18	1-101-004-00	CERAMIC	0.01MF	50V
C20	1-123-382-00	ELECT	3.3MF	20% 50V
C21	1-123-356-00	ELECT	10MF	20% 16V
C22	1-123-356-00	ELECT	10MF	20% 16V
C23	1-123-356-00	ELECT	10MF	20% 16V
C24	1-123-356-00	ELECT	10MF	20% 16V
C26	1-101-004-00	CERAMIC	0.01MF	50V
C41	1-124-122-11	ELECT	100MF	20% 16V
C42	1-123-356-00	ELECT	10MF	20% 16V
C43	1-123-356-00	ELECT	10MF	20% 16V
C44	1-123-356-00	ELECT	10MF	20% 16V
C45	1-123-356-00	ELECT	10MF	20% 16V
C50	1-123-356-00	ELECT	10MF	20% 16V
C51	1-101-004-00	CERAMIC	0.01MF	50V
C52	1-101-004-00	CERAMIC	0.01MF	50V
C53	1-101-004-00	CERAMIC	0.01MF	50V
C54	1-101-004-00	CERAMIC	0.01MF	50V
C55	1-101-004-00	CERAMIC	0.01MF	50V
C71	1-124-122-11	ELECT	100MF	20% 16V
C72	1-123-356-00	ELECT	10MF	20% 16V
C73	1-123-356-00	ELECT	10MF	20% 16V
C74	1-123-356-00	ELECT	10MF	20% 16V
C80	1-123-356-00	ELECT	10MF	20% 16V
C81	1-101-004-00	CERAMIC	0.01MF	50V
C82	1-101-004-00	CERAMIC	0.01MF	50V
C83	1-101-004-00	CERAMIC	0.01MF	50V
C84	1-101-004-00	CERAMIC	0.01MF	50V
C85	1-101-004-00	CERAMIC	0.01MF	50V
C86	1-101-004-00	CERAMIC	0.01MF	50V
C101	1-161-021-11	CERAMIC	0.047MF	10% 25V
C102	1-102-942-00	CERAMIC	5PF	0.5PF 50V
C103	1-102-959-00	CERAMIC	22PF	5% 50V
C104	1-123-356-00	ELECT	10MF	20% 16V
C105	1-161-021-11	CERAMIC	0.047MF	10% 25V
C106	1-101-004-00	CERAMIC	0.01MF	50V
C107	1-161-021-11	CERAMIC	0.047MF	10% 25V
C108	1-101-004-00	CERAMIC	0.01MF	50V
C109	1-101-004-00	CERAMIC	0.01MF	50V
C110	1-101-880-00	CERAMIC	47PF	5% 50V
C201	1-161-021-11	CERAMIC	0.047MF	10% 25V
C202	1-102-942-00	CERAMIC	5PF	0.5PF 50V
C203	1-102-959-00	CERAMIC	22PF	5% 50V
C204	1-123-356-00	ELECT	10MF	20% 16V
C205	1-161-021-11	CERAMIC	0.047MF	10% 25V
C206	1-101-004-00	CERAMIC	0.01MF	50V
C207	1-161-021-11	CERAMIC	0.047MF	10% 25V
C208	1-101-004-00	CERAMIC	0.01MF	50V
C209	1-101-004-00	CERAMIC	0.01MF	50V
C210	1-101-880-00	CERAMIC	47PF	5% 50V
C301	1-161-021-11	CERAMIC	0.047MF	10% 25V
C302	1-102-942-00	CERAMIC	5PF	0.5PF 50V
C303	1-102-959-00	CERAMIC	22PF	5% 50V
C304	1-123-356-00	ELECT	10MF	20% 16V
C305	1-161-021-11	CERAMIC	0.047MF	10% 25V
C306	1-101-004-00	CERAMIC	0.01MF	50V
C307	1-161-021-11	CERAMIC	0.047MF	10% 25V
C308	1-101-004-00	CERAMIC	0.01MF	50V
C309	1-101-004-00	CERAMIC	0.01MF	50V
C310	1-101-880-00	CERAMIC	47PF	5% 50V
<u>COMBINATION PARTS</u>				
CP17	1-232-096-00	COMPOSITION CIRCUIT BLOCK		

Ref.No	Part No.	Description	Remark
<u>DIODE</u>			
D1	8-719-911-19	DIODE 1SS119	
D101	8-719-911-19	DIODE 1SS119	
D102	8-719-911-19	DIODE 1SS119	
D201	8-719-911-19	DIODE 1SS119	
D202	8-719-911-19	DIODE 1SS119	
D301	8-719-911-19	DIODE 1SS119	
D302	8-719-911-19	DIODE 1SS119	
<u>IC</u>			
IC1	8-759-040-53	IC MC14053BCP	
IC2	8-759-040-53	IC MC14053BCP	
IC3	8-759-040-53	IC MC14053BCP	
IC4	8-759-040-53	IC MC14053BCP	
IC5	8-759-981-95	IC RC4558S	
IC6	8-759-981-95	IC RC4558S	
IC7	8-759-800-81	IC LA7016	
IC8	8-759-800-81	IC LA7016	
IC9	8-759-040-53	IC MC14053BCP	
IC10	8-759-040-53	IC MC14053BCP	
IC11	8-759-240-81	IC TC40818P	
IC12	8-759-240-81	IC TC40818P	
IC13	8-759-240-01	IC TC4001BP	
IC14	8-759-207-73	IC TC4030BPBH	
IC101	8-766-001-49	TRANSISTOR TX-429M	
IC102	8-759-990-82	IC TL082CP	
IC201	8-766-001-49	TRANSISTOR TX-429M	
IC202	8-759-990-82	IC TL082CP	
IC301	8-766-001-49	TRANSISTOR TX-429M	
IC302	8-759-990-82	IC TL082CP	
<u>TRANSISTOR</u>			
Q1	8-729-119-78	TRANSISTOR 2SC2785-HFE	
Q2	8-729-105-71	TRANSISTOR 2SK523-K2	
Q3	8-729-384-48	TRANSISTOR 2SA844-E	
Q4	8-729-119-78	TRANSISTOR 2SC2785-HFE	
Q5	8-729-105-71	TRANSISTOR 2SK523-K2	
Q6	8-729-384-48	TRANSISTOR 2SA844-E	
Q7	8-729-119-78	TRANSISTOR 2SC2785-HFE	
Q8	8-729-105-71	TRANSISTOR 2SK523-K2	
Q9	8-729-384-48	TRANSISTOR 2SA844-E	
Q10	8-729-119-78	TRANSISTOR 2SC2785-HFE	
Q11	8-729-105-71	TRANSISTOR 2SK523-K2	
Q12	8-729-384-48	TRANSISTOR 2SA844-E	
Q13	8-729-384-48	TRANSISTOR 2SA844-E	
Q14	8-729-384-48	TRANSISTOR 2SA844-E	
Q15	8-729-384-48	TRANSISTOR 2SA844-E	
Q16	8-729-800-10	TRANSISTOR 2SC3068	
Q101	8-729-600-19	TRANSISTOR 2SK381-A	
Q102	8-729-384-48	TRANSISTOR 2SA844-E	
Q103	8-729-119-78	TRANSISTOR 2SC2785-HFE	
Q104	8-729-119-78	TRANSISTOR 2SC2785-HFE	
Q105	8-729-119-78	TRANSISTOR 2SC2785-HFE	
Q106	8-729-600-19	TRANSISTOR 2SK381-A	
Q107	8-729-600-19	TRANSISTOR 2SK381-A	
Q108	8-729-600-19	TRANSISTOR 2SK381-A	
Q201	8-729-600-19	TRANSISTOR 2SK381-A	
Q202	8-729-384-48	TRANSISTOR 2SA844-E	
Q203	8-729-119-78	TRANSISTOR 2SC2785-HFE	
Q204	8-729-119-78	TRANSISTOR 2SC2785-HFE	
Q205	8-729-119-78	TRANSISTOR 2SC2785-HFE	
Q206	8-729-600-19	TRANSISTOR 2SK381-A	
Q207	8-729-600-19	TRANSISTOR 2SK381-A	
Q208	8-729-600-19	TRANSISTOR 2SK381-A	
Q301	8-729-600-19	TRANSISTOR 2SK381-A	

Ref.No	Part No.	Description	Remark
Q302	8-729-384-48	TRANSISTOR 2SA844-E	
Q303	8-729-119-78	TRANSISTOR 2SC403SPTP-5	
Q304	8-729-119-78	TRANSISTOR 2SC403SPTP-5	
Q305	8-729-119-78	TRANSISTOR 2SC403SPTP-5	
Q306	8-729-600-19	TRANSISTOR 2SK381-A	
Q307	8-729-600-19	TRANSISTOR 2SK381-A	
Q308	8-729-600-19	TRANSISTOR 2SK381-A	
<u>RESISTOR</u>			
R1	1-249-433-11	CARBON 22K 5%	1/4W
R3	1-249-427-11	CARBON 6.8K 5%	1/4W
R5	1-249-422-11	CARBON 2.7K 5%	1/4W
R6	1-249-433-11	CARBON 22K 5%	1/4W
R7	1-249-433-11	CARBON 22K 5%	1/4W
R9	1-249-427-11	CARBON 6.8K 5%	1/4W
R11	1-249-422-11	CARBON 2.7K 5%	1/4W
R12	1-249-433-11	CARBON 22K 5%	1/4W
R13	1-249-433-11	CARBON 22K 5%	1/4W
R15	1-249-427-11	CARBON 6.8K 5%	1/4W
R17	1-249-422-11	CARBON 2.7K 5%	1/4W
R18	1-249-433-11	CARBON 22K 5%	1/4W
R19	1-249-433-11	CARBON 22K 5%	1/4W
R21	1-249-427-11	CARBON 6.8K 5%	1/4W
R23	1-249-422-11	CARBON 2.7K 5%	1/4W
R31	1-249-405-11	CARBON 100 5%	1/4W
R32	1-249-405-11	CARBON 100 5%	1/4W
R33	1-249-433-11	CARBON 22K 5%	1/4W
R34	1-249-422-11	CARBON 2.7K 5%	1/4W
R35	1-249-405-11	CARBON 100 5%	1/4W
R36	1-249-405-11	CARBON 100 5%	1/4W
R37	1-249-433-11	CARBON 22K 5%	1/4W
R38	1-249-422-11	CARBON 2.7K 5%	1/4W
R39	1-249-433-11	CARBON 22K 5%	1/4W
R40	1-249-422-11	CARBON 2.7K 5%	1/4W
R52	1-249-417-11	CARBON 1K 5%	1/4W
R53	1-249-425-11	CARBON 4.7K 5%	1/4W
R54	1-249-441-11	CARBON 100K 5%	1/4W
R63	1-249-417-11	CARBON 1K 5%	1/4W
R64	1-249-437-11	CARBON 47K 5%	1/4W
R65	1-249-433-11	CARBON 22K 5%	1/4W
R66	1-249-417-11	CARBON 1K 5%	1/4W
R101	1-247-903-00	CARBON 1M 5%	1/4W
R102	1-249-431-11	CARBON 15K 5%	1/4W
R103	1-249-419-11	CARBON 1.5K 5%	1/4W
R104	1-249-430-11	CARBON 12K 5%	1/4W
R105	1-249-409-11	CARBON 220 5%	1/4W
R106	1-249-419-11	CARBON 1.5K 5%	1/4W
R107	1-215-425-00	METAL 1.5K 1%	1/6W
R108	1-249-415-11	CARBON 680 5%	1/4W
R109	1-249-419-11	CARBON 1.5K 5%	1/4W
R110	1-215-427-00	METAL 1.8K 1%	1/6W
R111	1-215-453-00	METAL 22K 1%	1/6W
R112	1-249-419-11	CARBON 1.5K 5%	1/4W
R113	1-249-405-11	CARBON 100 5%	1/4W
R114	1-215-445-00	METAL 10K 1%	1/6W
R115	1-215-445-00	METAL 10K 1%	1/6W
R116	1-249-429-11	CARBON 10K 5%	1/4W
R117	1-215-493-00	METAL 1M 1%	1/6W
R120	1-215-451-00	METAL 18K 1%	1/6W
R121	1-215-453-00	METAL 22K 1%	1/6W
R201	1-247-903-00	CARBON 1M 5%	1/4W
R202	1-249-431-11	CARBON 15K 5%	1/4W
R203	1-249-419-11	CARBON 1.5K 5%	1/4W
R204	1-249-430-11	CARBON 12K 5%	1/4W
R205	1-249-409-11	CARBON 220 5%	1/4W

Ref.No	Part No.	Description	Remark
R206	1-249-419-11	CARBON 1.5K 5%	1/4W
R207	1-215-425-00	METAL 1.5K 1%	1/6W
R208	1-249-415-11	CARBON 680 5%	1/4W
R209	1-249-419-11	CARBON 1.5K 5%	1/4W
R210	1-215-427-00	METAL 1.8K 1%	1/6W
R211	1-215-453-00	METAL 22K 1%	1/6W
R212	1-249-419-11	CARBON 1.5K 5%	1/4W
R213	1-249-405-11	CARBON 100 5%	1/4W
R214	1-215-445-00	METAL 10K 1%	1/6W
R215	1-215-445-00	METAL 10K 1%	1/6W
R216	1-249-429-11	CARBON 10K 5%	1/4W
R217	1-215-455-00	METAL 27K 1%	1/6W
R301	1-247-903-00	CARBON 1M 5%	1/4W
R302	1-249-431-11	CARBON 15K 5%	1/4W
R303	1-249-419-11	CARBON 1.5K 5%	1/4W
R304	1-249-430-11	CARBON 12K 5%	1/4W
R305	1-249-409-11	CARBON 220 5%	1/4W
R306	1-249-419-11	CARBON 1.5K 5%	1/4W
R307	1-215-425-00	METAL 1.5K 1%	1/6W
R308	1-249-415-11	CARBON 680 5%	1/4W
R309	1-249-419-11	CARBON 1.5K 5%	1/4W
R310	1-215-427-00	METAL 1.8K 1%	1/6W
R311	1-215-453-00	METAL 22K 1%	1/6W
R312	1-249-419-11	CARBON 1.5K 5%	1/4W
R313	1-249-405-11	CARBON 100 5%	1/4W
R314	1-215-445-00	METAL 10K 1%	1/6W
R315	1-215-445-00	METAL 10K 1%	1/6W
R316	1-249-429-11	CARBON 10K 5%	1/4W
<u>VARIABLE RESISTOR</u>			
RV1	1-237-505-21	RES, ADJ, CERMET 50K	
RV2	1-237-505-21	RES, ADJ, CERMET 50K	
RV3	1-237-505-21	RES, ADJ, CERMET 50K	
<u>SWITCH</u>			
S1	1-570-857-11	SWITCH, SLIDE	
S2	1-570-851-11	SWITCH, SLIDE	

		*A-1135-360-A	BI BOARD, COMPLETE

		*4-353-708-00	HOOK, FINGER
		7-682-547-04	SCREW BVTT 3X6 (S)
<u>CAPACITOR</u>			
C1	1-130-481-00	MYLAR 0.0068MF	5% 50V
C2	1-136-165-00	FILM 0.1MF	5% 50V
C3	1-123-369-00	ELECT 4.7MF	20% 25V
C4	1-123-369-00	ELECT 4.7MF	20% 25V
C5	1-102-973-00	CERAMIC 100PF	5% 50V
C7	1-123-330-00	ELECT 22MF	20% 25V
C8	1-123-369-00	ELECT 4.7MF	20% 25V
C11	1-123-356-00	ELECT 10MF	20% 16V
C12	1-101-004-00	CERAMIC 0.01MF	50V
C13	1-101-004-00	CERAMIC 0.01MF	50V
C14	1-101-004-00	CERAMIC 0.01MF	50V
C15	1-123-330-00	ELECT 22MF	20% 16V
C16	1-123-356-00	ELECT 10MF	20% 16V
C17	1-101-004-00	CERAMIC 0.01MF	50V
C18	1-101-004-00	CERAMIC 0.01MF	50V
C19	1-101-004-00	CERAMIC 0.01MF	50V
C41	1-124-034-51	ELECT 33MF	20% 16V
C42	1-124-034-51	ELECT 33MF	20% 16V
C43	1-124-034-51	ELECT 33MF	20% 16V



7. ELECTRICAL PARTS LIST

Ref.No	Part No.	Description	Remark
C44	1-124-034-51	ELECT	33MF 20% 16V
C45	1-124-034-51	ELECT	33MF 20% 16V
C46	1-124-034-51	ELECT	33MF 20% 16V
C51	1-101-004-00	CERAMIC	0.01MF 50V
C52	1-101-004-00	CERAMIC	0.01MF 50V
C53	1-101-004-00	CERAMIC	0.01MF 50V
C54	1-101-004-00	CERAMIC	0.01MF 50V
C55	1-101-004-00	CERAMIC	0.01MF 50V
C56	1-101-004-00	CERAMIC	0.01MF 50V
C57	1-101-004-00	CERAMIC	0.01MF 50V
C71	1-124-034-51	ELECT	33MF 20% 16V
C72	1-124-034-51	ELECT	33MF 20% 16V
C73	1-124-034-51	ELECT	33MF 20% 16V
C74	1-124-034-51	ELECT	33MF 20% 16V
C75	1-124-034-51	ELECT	33MF 20% 16V
C76	1-124-034-51	ELECT	33MF 20% 16V
C81	1-101-004-00	CERAMIC	0.01MF 50V
C82	1-101-004-00	CERAMIC	0.01MF 50V
C83	1-101-004-00	CERAMIC	0.01MF 50V
C84	1-101-004-00	CERAMIC	0.01MF 50V
C85	1-101-004-00	CERAMIC	0.01MF 50V
C86	1-101-004-00	CERAMIC	0.01MF 50V
C87	1-101-004-00	CERAMIC	0.01MF 50V
C101	1-101-004-00	CERAMIC	0.01MF 50V
C102	1-123-380-00	ELECT	1MF 20% 50V
C104	1-123-356-00	ELECT	10MF 20% 16V
C105	1-101-004-00	CERAMIC	0.01MF 50V
C106	1-136-161-00	FILM	0.047MF 5% 50V
C107	1-102-937-00	CERAMIC	4PF 0.25PF 50V
C108	1-101-880-00	CERAMIC	47PF 5% 50V
C109	1-136-161-00	FILM	0.047MF 5% 50V
C110	1-136-161-00	FILM	0.047MF 5% 50V
C114	1-102-951-00	CERAMIC	15PF 5% 50V
C115	1-136-153-00	FILM	0.01MF 5% 50V
C116	1-102-973-00	CERAMIC	100PF 5% 50V
C117	1-101-004-00	CERAMIC	0.01MF 50V
C118	1-101-004-00	CERAMIC	0.01MF 50V
C119	1-102-953-00	CERAMIC	18PF 5% 50V
C120	1-102-038-00	CERAMIC	0.001MF 500V
C122	1-102-943-00	CERAMIC	6PF 0.5PF 50V
C201	1-101-004-00	CERAMIC	0.01MF 50V
C202	1-123-380-00	ELECT	1MF 20% 50V
C204	1-123-356-00	ELECT	10MF 20% 16V
C205	1-101-004-00	CERAMIC	0.01MF 50V
C206	1-136-161-00	FILM	0.047MF 5% 50V
C207	1-102-937-00	CERAMIC	4PF 0.25PF 50V
C208	1-101-880-00	CERAMIC	47PF 5% 50V
C209	1-136-161-00	FILM	0.047MF 5% 50V
C210	1-136-161-00	FILM	0.047MF 5% 50V
C214	1-102-951-00	CERAMIC	15PF 5% 50V
C215	1-136-153-00	FILM	0.01MF 5% 50V
C216	1-102-973-00	CERAMIC	100PF 5% 50V
C217	1-101-004-00	CERAMIC	0.01MF 50V
C218	1-101-004-00	CERAMIC	0.01MF 50V
C219	1-102-953-00	CERAMIC	18PF 5% 50V
C220	1-102-038-00	CERAMIC	0.001MF 500V
C222	1-102-943-00	CERAMIC	6PF 0.5PF 50V
C301	1-101-004-00	CERAMIC	0.01MF 50V
C302	1-123-380-00	ELECT	1MF 20% 50V
C304	1-123-356-00	ELECT	10MF 20% 16V
C305	1-101-004-00	CERAMIC	0.01MF 50V
C306	1-136-161-00	FILM	0.047MF 5% 50V
C307	1-102-937-00	CERAMIC	4PF 0.25PF 50V
C308	1-101-880-00	CERAMIC	47PF 5% 50V
C309	1-136-161-00	FILM	0.047MF 5% 50V

Ref.No	Part No.	Description	Remark
C310	1-136-161-00	FILM	0.047MF 5% 50V
C314	1-102-951-00	CERAMIC	15PF 5% 50V
C315	1-136-153-00	FILM	0.01MF 5% 50V
C316	1-102-973-00	CERAMIC	100PF 5% 50V
C317	1-101-004-00	CERAMIC	0.01MF 50V
C318	1-101-004-00	CERAMIC	0.01MF 50V
C319	1-102-953-00	CERAMIC	18PF 5% 50V
C320	1-102-038-00	CERAMIC	0.001MF 500V
C322	1-102-943-00	CERAMIC	6PF 0.5PF 50V

DIODE

Ref.No	Part No.	Description	Remark
D1	8-719-911-19	DIODE 1SS119	
D2	8-719-911-19	DIODE 1SS119	
D4	8-719-911-19	DIODE 1SS119	
D5	8-719-911-19	DIODE 1SS119	
D6	8-719-110-31	DIODE RD12ES-B2	
D7	8-719-911-19	DIODE 1SS119	
D8	8-719-911-19	DIODE 1SS119	
D101	8-719-911-19	DIODE 1SS119	
D102	8-719-016-42	DIODE MC932	
D103	8-719-109-74	DIODE RD4.3ES-B1	
D104	8-719-911-19	DIODE 1SS119	
D105	8-719-109-93	DIODE RD6.2ES-B2	
D201	8-719-911-19	DIODE 1SS119	
D202	8-719-016-42	DIODE MC932	
D203	8-719-109-74	DIODE RD4.3ES-B1	
D204	8-719-911-19	DIODE 1SS119	
D205	8-719-109-93	DIODE RD6.2ES-B2	
D301	8-719-911-19	DIODE 1SS119	
D302	8-719-016-42	DIODE MC932	
D303	8-719-109-74	DIODE RD4.3ES-B1	
D304	8-719-911-19	DIODE 1SS119	
D305	8-719-109-93	DIODE RD6.2ES-B2	

IC

Ref.No	Part No.	Description	Remark
IC1	8-759-945-58	IC RC4558P	
IC101	8-759-040-53	IC MC14053BCP	
IC102	8-766-001-49	TRANSISTOR TX-429M	
IC103	8-759-990-82	IC TL082CP	
IC104	8-759-990-82	IC TL082CP	
IC105	8-759-990-82	IC TL082CP	
IC201	8-759-040-53	IC MC14053BCP	
IC202	8-766-001-49	TRANSISTOR TX-429M	
IC203	8-759-990-82	IC TL082CP	
IC204	8-759-990-82	IC TL082CP	
IC205	8-759-990-82	IC TL082CP	
IC301	8-759-040-53	IC MC14053BCP	
IC302	8-766-001-49	TRANSISTOR TX-429M	
IC303	8-759-990-82	IC TL082CP	
IC304	8-759-990-82	IC TL082CP	
IC305	8-759-990-82	IC TL082CP	

TRANSISTOR

Ref.No	Part No.	Description	Remark
Q1	8-729-900-74	TRANSISTOR DTC143TS	
Q2	8-729-119-78	TRANSISTOR 2SC2785-HFE	
Q3	8-729-119-78	TRANSISTOR 2SC2785-HFE	
Q11	8-729-201-05	TRANSISTOR 2SC2878-B	
Q12	8-729-201-05	TRANSISTOR 2SC2878-B	
Q13	8-729-201-05	TRANSISTOR 2SC2878-B	
Q14	8-729-201-05	TRANSISTOR 2SC2878-B	
Q15	8-729-900-65	TRANSISTOR DTA144ES	
Q101	8-729-384-48	TRANSISTOR 2SA844-E	
Q102	8-729-384-48	TRANSISTOR 2SA844-E	
Q103	8-729-384-48	TRANSISTOR 2SA844-E	
Q105	8-729-600-19	TRANSISTOR 2SK381-A	

Ref.No	Part No.	Description	Remark	Ref.No	Part No.	Description	Remark
Q106	8-729-384-48	TRANSISTOR 2SA844-E		R108	1-249-430-11	CARBON 12K 5%	1/4W
Q107	8-729-266-82	TRANSISTOR 2SC2668-O		R109	1-249-417-11	CARBON 1K 5%	1/4W
Q108	8-729-384-48	TRANSISTOR 2SA844-E		R110	1-249-441-11	CARBON 100K 5%	1/4W
Q109	8-729-600-19	TRANSISTOR 2SK381-A		R111	1-249-417-11	CARBON 1K 5%	1/4W
Q110	8-729-600-19	TRANSISTOR 2SK381-A		R112	1-249-417-11	CARBON 1K 5%	1/4W
Q113	8-729-600-19	TRANSISTOR 2SK381-A		R113	1-247-903-00	CARBON 1M 5%	1/4W
Q114	8-729-200-17	TRANSISTOR 2SA1091-O		R114	1-249-419-11	CARBON 1.5K 5%	1/4W
Q201	8-729-384-48	TRANSISTOR 2SA844-E		R115	1-249-419-11	CARBON 1.5K 5%	1/4W
Q202	8-729-384-48	TRANSISTOR 2SA844-E		R116	1-249-424-11	CARBON 3.9K 5%	1/4W
Q203	8-729-384-48	TRANSISTOR 2SA844-E		R117	1-249-419-11	CARBON 1.5K 5%	1/4W
Q205	8-729-600-19	TRANSISTOR 2SK381-A		R118	1-215-421-00	METAL 1K 1%	1/6W
Q206	8-729-384-48	TRANSISTOR 2SA844-E		R119	1-249-405-11	CARBON 100 5%	1/4W
Q207	8-729-266-82	TRANSISTOR 2SC2668-O		R120	1-249-405-11	CARBON 100 5%	1/4W
Q208	8-729-384-48	TRANSISTOR 2SA844-E		R121	1-249-409-11	CARBON 220 5%	1/4W
Q209	8-729-600-19	TRANSISTOR 2SK381-A		R122	1-215-427-00	METAL 1.8K 1%	1/6W
Q210	8-729-600-19	TRANSISTOR 2SK381-A		R123	1-249-429-11	CARBON 10K 5%	1/4W
Q213	8-729-600-19	TRANSISTOR 2SK381-A		R124	1-249-429-11	CARBON 10K 5%	1/4W
Q214	8-729-200-17	TRANSISTOR 2SA1091-O		R125	1-249-422-11	CARBON 2.7K 5%	1/4W
Q301	8-729-384-48	TRANSISTOR 2SA844-E		R127	1-215-453-00	METAL 22K 1%	1/6W
Q302	8-729-384-48	TRANSISTOR 2SA844-E		R128	1-215-445-00	METAL 10K 1%	1/6W
Q303	8-729-384-48	TRANSISTOR 2SA844-E		R136	1-215-477-00	METAL 220K 1%	1/6W
Q305	8-729-600-19	TRANSISTOR 2SK381-A		R137	1-249-417-11	CARBON 1K 5%	1/4W
Q306	8-729-384-48	TRANSISTOR 2SA844-E		R138	1-249-441-11	CARBON 100K 5%	1/4W
Q307	8-729-266-82	TRANSISTOR 2SC2668-O		R140	1-249-429-11	CARBON 10K 5%	1/4W
Q308	8-729-384-48	TRANSISTOR 2SA844-E		R141	1-215-469-00	METAL 100K 1%	1/6W
Q309	8-729-600-19	TRANSISTOR 2SK381-A		R142	1-215-455-00	METAL 27K 1%	1/6W
Q310	8-729-600-19	TRANSISTOR 2SK381-A		R143	1-215-488-00	METAL 620K 1%	1/6W
Q313	8-729-600-19	TRANSISTOR 2SK381-A		R144	1-249-434-11	CARBON 27K 5%	1/4W
Q314	8-729-200-17	TRANSISTOR 2SA1091-O		R146	1-249-417-11	CARBON 1K 5%	1/4W
				R147	1-249-405-11	CARBON 100 5%	1/4W
<u>RESISTOR</u>				R201	1-249-441-11	CARBON 100K 5%	1/4W
R1	1-247-903-00	CARBON 1M 5%	1/4W	R202	1-249-421-11	CARBON 2.2K 5%	1/4W
R2	1-249-429-11	CARBON 10K 5%	1/4W	R204	1-215-469-00	METAL 100K 1%	1/6W
R3	1-215-493-00	METAL 1M 1%	1/6W	R205	1-215-477-00	METAL 220K 1%	1/6W
R4	1-215-469-00	METAL 100K 1%	1/6W	R206	1-215-427-00	METAL 1.8K 1%	1/6W
R5	1-249-435-11	CARBON 33K 5%	1/4W	R207	1-249-435-11	CARBON 33K 5%	1/4W
R8	1-249-441-11	CARBON 100K 5%	1/4W	R208	1-249-430-11	CARBON 12K 5%	1/4W
R9	1-249-424-11	CARBON 3.9K 5%	1/4W	R209	1-249-417-11	CARBON 1K 5%	1/4W
R10	1-249-425-11	CARBON 4.7K 5%	1/4W	R210	1-249-441-11	CARBON 100K 5%	1/4W
R11	1-249-435-11	CARBON 33K 5%	1/4W	R211	1-249-417-11	CARBON 1K 5%	1/4W
R12	1-249-429-11	CARBON 10K 5%	1/4W	R212	1-249-417-11	CARBON 1K 5%	1/4W
R13	1-249-425-11	CARBON 4.7K 5%	1/4W	R213	1-247-903-00	CARBON 1M 5%	1/4W
R14	1-249-435-11	CARBON 33K 5%	1/4W	R214	1-249-419-11	CARBON 1.5K 5%	1/4W
R15	1-249-429-11	CARBON 10K 5%	1/4W	R215	1-249-419-11	CARBON 1.5K 5%	1/4W
R23	1-249-417-11	CARBON 1K 5%	1/4W	R216	1-249-424-11	CARBON 3.9K 5%	1/4W
R24	1-249-417-11	CARBON 1K 5%	1/4W	R217	1-249-419-11	CARBON 1.5K 5%	1/4W
R25	1-249-417-11	CARBON 1K 5%	1/4W	R218	1-215-421-00	METAL 1K 1%	1/6W
R31	1-249-430-11	CARBON 12K 5%	1/4W	R219	1-249-405-11	CARBON 100 5%	1/4W
R32	1-249-436-11	CARBON 39K 5%	1/4W	R220	1-249-405-11	CARBON 100 5%	1/4W
R33	1-249-430-11	CARBON 12K 5%	1/4W	R221	1-249-409-11	CARBON 220 5%	1/4W
R51	1-249-417-11	CARBON 1K 5%	1/4W	R222	1-215-427-00	METAL 1.8K 1%	1/6W
R52	1-249-417-11	CARBON 1K 5%	1/4W	R223	1-249-429-11	CARBON 10K 5%	1/4W
R53	1-249-417-11	CARBON 1K 5%	1/4W	R224	1-249-429-11	CARBON 10K 5%	1/4W
R54	1-249-431-11	CARBON 15K 5%	1/4W	R225	1-249-422-11	CARBON 2.7K 5%	1/4W
R55	1-249-437-11	CARBON 47K 5%	1/4W	R227	1-215-453-00	METAL 22K 1%	1/6W
R56	1-249-431-11	CARBON 15K 5%	1/4W	R228	1-215-445-00	METAL 10K 1%	1/6W
R57	1-249-431-11	CARBON 15K 5%	1/4W	R236	1-215-477-00	METAL 220K 1%	1/6W
R58	1-249-439-11	CARBON 68K 5%	1/4W	R237	1-249-417-11	CARBON 1K 5%	1/4W
R60	1-215-465-00	METAL 68K 1%	1/6W	R238	1-249-441-11	CARBON 100K 5%	1/4W
R61	1-215-445-00	METAL 10K 1%	1/6W	R240	1-249-429-11	CARBON 10K 5%	1/4W
R101	1-249-441-11	CARBON 100K 5%	1/4W	R241	1-215-469-00	METAL 100K 1%	1/6W
R102	1-249-421-11	CARBON 2.2K 5%	1/4W	R242	1-215-455-00	METAL 27K 1%	1/6W
R104	1-215-469-00	METAL 100K 1%	1/6W	R243	1-215-488-00	METAL 620K 1%	1/6W
R105	1-215-477-00	METAL 220K 1%	1/6W	R244	1-249-434-11	CARBON 27K 5%	1/4W
R106	1-215-427-00	METAL 1.8K 1%	1/6W	R246	1-249-417-11	CARBON 1K 5%	1/4W
R107	1-249-435-11	CARBON 33K 5%	1/4W				

BI **BJ**

Ref.No	Part No.	Description	Remark
R247	1-249-405-11	CARBON 100 5% 1/4W	
R301	1-249-441-11	CARBON 100K 5% 1/4W	
R302	1-249-421-11	CARBON 2.2K 5% 1/4W	
R304	1-215-469-00	METAL 100K 1% 1/6W	
R305	1-215-477-00	METAL 220K 1% 1/6W	
R306	1-215-427-00	METAL 1.8K 1% 1/6W	
R307	1-249-435-11	CARBON 33K 5% 1/4W	
R308	1-249-430-11	CARBON 12K 5% 1/4W	
R309	1-249-417-11	CARBON 1K 5% 1/4W	
R310	1-249-441-11	CARBON 100K 5% 1/4W	
R311	1-249-417-11	CARBON 1K 5% 1/4W	
R312	1-249-417-11	CARBON 1K 5% 1/4W	
R313	1-247-903-00	CARBON 1M 5% 1/4W	
R314	1-249-419-11	CARBON 1.5K 5% 1/4W	
R315	1-249-419-11	CARBON 1.5K 5% 1/4W	
R316	1-249-424-11	CARBON 3.9K 5% 1/4W	
R317	1-249-419-11	CARBON 1.5K 5% 1/4W	
R318	1-215-421-00	METAL 1K 1% 1/6W	
R319	1-249-405-11	CARBON 100 5% 1/4W	
R320	1-249-405-11	CARBON 100 5% 1/4W	
R321	1-249-409-11	CARBON 220 5% 1/4W	
R322	1-215-427-00	METAL 1.8K 1% 1/6W	
R323	1-249-429-11	CARBON 10K 5% 1/4W	
R324	1-249-429-11	CARBON 10K 5% 1/4W	
R325	1-249-422-11	CARBON 2.7K 5% 1/4W	
R327	1-215-453-00	METAL 22K 1% 1/6W	
R328	1-215-445-00	METAL 10K 1% 1/6W	
R336	1-215-477-00	METAL 220K 1% 1/6W	
R337	1-249-417-11	CARBON 1K 5% 1/4W	
R338	1-249-441-11	CARBON 100K 5% 1/4W	
R340	1-249-429-11	CARBON 10K 5% 1/4W	
R341	1-215-469-00	METAL 100K 1% 1/6W	
R342	1-215-455-00	METAL 27K 1% 1/6W	
R343	1-215-488-00	METAL 620K 1% 1/6W	
R344	1-249-434-11	CARBON 27K 5% 1/4W	
R346	1-249-417-11	CARBON 1K 5% 1/4W	
R347	1-249-405-11	CARBON 100 5% 1/4W	

Ref.No	Part No.	Description	Remark
C28	1-130-471-00	MYLAR 0.001MF 5% 50V	
C29	1-130-471-00	MYLAR 0.001MF 5% 50V	
C30	1-101-004-00	CERAMIC 0.01MF 50V	
C31	1-101-361-00	CERAMIC 150PF 5% 50V	
C32	1-101-361-00	CERAMIC 150PF 5% 50V	
C33	1-101-361-00	CERAMIC 150PF 5% 50V	
C34	1-101-361-00	CERAMIC 150PF 5% 50V	
C35	1-130-471-00	MYLAR 0.001MF 5% 50V	
C36	1-102-824-00	CERAMIC 470PF 5% 50V	
C37	1-123-380-00	ELECT 1MF 20% 50V	
C38	1-101-004-00	CERAMIC 0.01MF 50V	
C39	1-101-004-00	CERAMIC 0.01MF 50V	
C40	1-102-074-00	CERAMIC 0.001MF 10% 50V	
C61	1-101-888-00	CERAMIC 68PF 5% 50V	
C62	1-101-880-00	CERAMIC 47PF 5% 50V	
C63	1-101-888-00	CERAMIC 68PF 5% 50V	
C64	1-101-880-00	CERAMIC 47PF 5% 50V	
C65	1-102-820-00	CERAMIC 330PF 5% 50V	
C66	1-101-004-00	CERAMIC 0.01MF 50V	
C67	1-101-880-00	CERAMIC 47PF 5% 50V	
C100	1-123-332-00	ELECT 47MF 20% 16V	
C102	1-124-034-51	ELECT 33MF 20% 16V	
C106	1-101-004-00	CERAMIC 0.001MF 50V	
C108	1-124-034-51	ELECT 33MF 20% 16V	
C109	1-101-004-00	CERAMIC 0.01MF 50V	
C110	1-101-004-00	CERAMIC 0.01MF 50V	
C111	1-101-004-00	CERAMIC 0.01MF 50V	
C112	1-101-004-00	CERAMIC 0.01MF 50V	
C113	1-101-004-00	CERAMIC 0.01MF 50V	
C114	1-123-356-00	ELECT 10MF 20% 16V	
C115	1-101-004-00	CERAMIC 0.01MF 50V	
C116	1-101-004-00	CERAMIC 0.01MF 50V	
C117	1-101-004-00	CERAMIC 0.01MF 50V	
C118	1-123-356-00	ELECT 10MF 20% 16V	
C120	1-101-004-00	CERAMIC 0.01MF 50V	
C121	1-101-004-00	CERAMIC 0.01MF 50V	
C122	1-101-004-00	CERAMIC 0.01MF 50V	
C130	1-124-034-51	ELECT 33MF 20% 16V	

*A-1135-361-A BJ BOARD, COMPLETE

*4-353-708-00 HOOK, FINGER
7-682-547-04 SCREW BVTT 3X6 (S)

CAPACITOR

C1	1-101-361-00	CERAMIC 150PF 5% 50V	
C2	1-101-361-00	CERAMIC 150PF 5% 50V	
C4	1-102-821-00	CERAMIC 360PF 5% 50V	
C5	1-130-473-00	MYLAR 0.0015MF 5% 50V	
C11	1-104-302-11	POLYSTYRENE 0.001MF 5% 50V	
C12	1-101-888-00	CERAMIC 68PF 5% 50V	
C14	1-101-888-00	CERAMIC 68PF 5% 50V	
C15	1-101-888-00	CERAMIC 68PF 5% 50V	
C16	1-101-888-00	CERAMIC 68PF 5% 50V	
C17	1-101-888-00	CERAMIC 68PF 5% 50V	
C18	1-104-302-11	POLYSTYRENE 0.001MF 5% 50V	
C19	1-102-973-00	CERAMIC 100PF 5% 50V	
C20	1-101-888-00	CERAMIC 68PF 5% 50V	
C21	1-101-361-00	CERAMIC 150PF 5% 50V	
C22	1-101-890-00	CERAMIC 75PF 5% 50V	
C23	1-102-965-00	CERAMIC 39PF 5% 50V	
C25	1-102-811-	CERAMIC 9PF 1PF 50V	
C26	1-102-944-00	CERAMIC 7PF 1PF 50V	
C27	1-101-361-00	CERAMIC 150PF 5% 50V	

DIODE

D1	8-719-911-19	DIODE 1SS119	
D2	8-719-911-19	DIODE 1SS119	
D3	8-719-911-19	DIODE 1SS119	
D7	8-719-911-19	DIODE 1SS119	
D8	8-719-911-19	DIODE 1SS119	
D9	8-719-911-19	DIODE 1SS119	
D11	8-719-016-42	DIODE MC932	

IC

IC1	8-759-345-38	IC HD14538BP	
IC2	8-759-240-01	IC TC4001BP	
IC3	8-759-240-40	IC TC4040BP	
IC4	8-759-240-40	IC TC4040BP	
IC5	8-759-000-35	IC MC14027BCP	
IC6	8-759-000-35	IC MC14027BCP	
IC7	8-759-000-35	IC MC14027BCP	
IC8	8-759-000-35	IC MC14027BCP	
IC9	8-759-000-35	IC MC14027BCP	
IC10	8-759-345-38	IC HD14538BP	
IC11	8-759-345-38	IC HD14538BP	
IC12	8-759-345-38	IC HD14538BP	
IC13	8-759-240-01	IC TC4001BP	
IC14	8-759-240-01	IC TC4001BP	
IC15	8-759-240-71	IC TC4071BP	
IC16	8-759-140-11	IC TC4011BP	

Ref.No	Part No.	Description	Remark
IC17	8-759-240-11	IC TC4011BP	
IC18	8-759-000-32	IC MC14023BCP	
IC19	8-759-240-81	IC TC4081BP	
IC20	8-759-240-81	IC TC4081BP	
IC21	8-759-240-71	IC TC4071BP	
IC22	8-759-240-71	IC TC4071BP	
IC22	8-759-240-71	IC TC4071BP	
IC23	8-759-040-73	IC MC14073BCP	
IC24	8-759-000-51	IC MC14069UBC	
IC25	8-759-000-51	IC MC14069UBC	
IC26	8-759-041-75	IC MC14175BCP	
IC27	8-759-140-53	IC UPD4053BCP	
IC28	8-759-208-04	IC TC4520BP	
IC29	8-759-345-38	IC HD14538BP	
<u>COIL</u>			
L1	1-408-098-00	INDUCTOR 560UH	
L2	1-408-098-00	INDUCTOR 560UH	
L3	1-408-100-00	INDUCTOR 680UH	
<u>TRANSISTOR</u>			
Q14	8-729-119-78	TRANSISTOR 2SC2785-HFE	
Q15	8-729-119-78	TRANSISTOR 2SC2785-HFE	
Q16	8-729-119-78	TRANSISTOR 2SC2785-HFE	
Q17	8-729-119-78	TRANSISTOR 2SC2785-HFE	
Q18	8-729-119-78	TRANSISTOR 2SC2785-HFE	
Q19	8-729-119-76	TRANSISTOR 2SA1175-HFE	
Q20	8-729-119-78	TRANSISTOR 2SC2785-HFE	
Q21	8-729-119-78	TRANSISTOR 2SC2785-HFE	
Q22	8-729-119-78	TRANSISTOR 2SC2785-HFE	
Q23	8-729-119-76	TRANSISTOR 2SA1175-HFE	
Q24	8-729-119-78	TRANSISTOR 2SC2785-HFE	
Q25	8-729-119-78	TRANSISTOR 2SC2785-HFE	
Q26	8-729-119-78	TRANSISTOR 2SC2785-HFE	
<u>RESISTOR</u>			
R2	1-215-439-00	METAL 5.6K 1% 1/6W	
R3	1-249-422-11	CARBON 2.7K 5% 1/4W	
R4	1-215-449-00	METAL 15K 1% 1/6W	
R5	1-249-441-11	CARBON 100K 5% 1/4W	
R6	1-249-425-11	CARBON 4.7K 5% 1/4W	
R7	1-215-439-00	METAL 5.6K 1% 1/6W	
R37	1-249-441-11	CARBON 100K 5% 1/4W	
R38	1-215-454-00	METAL 24K 1% 1/6W	
R39	1-249-422-11	CARBON 2.7K 5% 1/4W	
R42	1-249-433-11	CARBON 22K 5% 1/4W	
R43	1-247-876-11	CARBON 75K 5% 1/4W	
R44	1-249-429-11	CARBON 10K 5% 1/4W	
R45	1-249-441-11	CARBON 100K 5% 1/4W	
R46	1-249-441-11	CARBON 100K 5% 1/4W	
R47	1-247-862-11	CARBON 20K 5% 1/4W	
R48	1-215-467-00	METAL 82K 1% 1/6W	
R49	1-249-422-11	CARBON 2.7K 5% 1/4W	
R50	1-215-469-00	METAL 100K 1% 1/6W	
R51	1-215-445-00	METAL 10K 1% 1/6W	
R52	1-247-885-00	CARBON 180K 5% 1/4W	
R53	1-215-449-00	METAL 15K 1% 1/6W	
R54	1-249-422-11	CARBON 2.7K 5% 1/4W	
R56	1-249-434-11	CARBON 27K 5% 1/4W	
R57	1-249-422-11	CARBON 2.7K 5% 1/4W	
R58	1-249-425-11	CARBON 4.7K 5% 1/4W	
R59	1-247-836-11	CARBON 1.6K 5% 1/4W	
R60	1-249-427-11	CARBON 6.8K 5% 1/4W	
R61	1-215-449-00	METAL 15K 1% 1/6W	
R62	1-249-433-11	CARBON 22K 5% 1/4W	
R63	1-249-425-11	CARBON 4.7K 5% 1/4W	

Ref.No	Part No.	Description	Remark
R64	1-249-425-11	CARBON 4.7K 5% 1/4W	
R65	1-249-417-11	CARBON 1K 5% 1/4W	
R66	1-249-430-11	CARBON 12K 5% 1/4W	
R67	1-249-425-11	CARBON 4.7K 5% 1/4W	
R68	1-249-433-11	CARBON 22K 5% 1/4W	
R69	1-249-425-11	CARBON 4.7K 5% 1/4W	
R70	1-249-417-11	CARBON 1K 5% 1/4W	
R71	1-249-430-11	CARBON 12K 5% 1/4W	
R72	1-249-433-11	CARBON 22K 5% 1/4W	
R74	1-249-430-11	CARBON 12K 5% 1/4W	
R75	1-249-422-11	CARBON 2.7K 5% 1/4W	
R76	1-215-463-00	METAL 56K 1% 1/6W	
R77	1-215-475-00	METAL 180K 1% 1/6W	
R78	1-215-439-00	METAL 5.6K 1% 1/6W	
R79	1-249-425-11	CARBON 4.7K 5% 1/4W	
R80	1-249-433-11	CARBON 22K 5% 1/4W	
R81	1-249-425-11	CARBON 4.7K 5% 1/4W	
R82	1-249-415-11	CARBON 680 5% 1/4W	
R83	1-249-417-11	CARBON 1K 5% 1/4W	
R85	1-249-430-11	CARBON 12K 5% 1/4W	
R87	1-249-422-11	CARBON 2.7K 5% 1/4W	
R89	1-247-887-00	CARBON 220K 5% 1/4W	
R90	1-249-441-11	CARBON 100K 5% 1/4W	
R91	1-249-441-11	CARBON 100K 5% 1/4W	
R92	1-249-441-11	CARBON 100K 5% 1/4W	
R93	1-249-429-11	CARBON 10K 5% 1/4W	
R94	1-249-429-11	CARBON 10K 5% 1/4W	
R95	1-249-441-11	CARBON 100K 5% 1/4W	
R96	1-249-417-11	CARBON 1K 5% 1/4W	
R100	1-249-423-11	CARBON 3.3K 5% 1/4W	
R111	1-249-427-11	CARBON 6.8K 5% 1/4W	
R112	1-249-429-11	CARBON 10K 5% 1/4W	
R113	1-249-429-11	CARBON 10K 5% 1/4W	
R114	1-249-422-11	CARBON 2.7K 5% 1/4W	
R115	1-249-419-11	CARBON 1.5K 5% 1/4W	
R116	1-249-427-11	CARBON 6.8K 5% 1/4W	
R117	1-249-429-11	CARBON 10K 5% 1/4W	
R118	1-249-429-11	CARBON 10K 5% 1/4W	
R119	1-249-422-11	CARBON 2.7K 5% 1/4W	
R120	1-249-419-11	CARBON 1.5K 5% 1/4W	
R121	1-249-417-11	CARBON 1K 5% 1/4W	
R122	1-249-417-11	CARBON 1K 5% 1/4W	
R123	1-249-413-11	CARBON 470 5% 1/4W	
R124	1-249-417-11	CARBON 1K 5% 1/4W	
R125	1-249-417-11	CARBON 1K 5% 1/4W	
R126	1-249-417-11	CARBON 1K 5% 1/4W	
R127	1-249-417-11	CARBON 1K 5% 1/4W	
R128	1-249-417-11	CARBON 1K 5% 1/4W	
R129	1-249-417-11	CARBON 1K 5% 1/4W	
<u>VARIABLE RESISTOR</u>			
RV1	1-237-504-21	RES, ADJ, CERMET 20K	
RV3	1-237-504-21	RES, ADJ, CERMET 20K	
RV4	1-237-503-21	RES, ADJ, CERMET 10K	
RV5	1-237-506-21	RES, ADJ, CERMET 100K	
RV6	1-237-505-21	RES, ADJ, CERMET 50K	
RV7	1-237-504-21	RES, ADJ, CERMET 20K	
RV8	1-237-504-21	RES, ADJ, CERMET 20K	
RV9	1-237-505-21	RES, ADJ, CERMET 50K	
<u>SWITCH</u>			
S1	1-570-857-11	SWITCH, SLIDE	

Ref.No	Part No.	Description	Remark	Ref.No	Part No.	Description	Remark
D202	8-719-911-19	DIODE 1SS119		Q212	8-729-255-12	TRANSISTOR 2SC2551-O	
D203	8-719-911-19	DIODE 1SS119		Q213	8-729-119-78	TRANSISTOR 2SC2785-HFE	
D204	8-719-911-19	DIODE 1SS119		Q214	8-729-119-78	TRANSISTOR 2SC2785-HFE	
D205	8-719-911-19	DIODE 1SS119		Q215	8-729-119-78	TRANSISTOR 2SC2785-HFE	
D206	8-719-911-19	DIODE 1SS119		Q301	8-729-266-82	TRANSISTOR 2SC2668-B	
D207	8-719-911-19	DIODE 1SS119		Q302	8-729-384-48	TRANSISTOR 2SA844-E	
D208	8-719-911-19	DIODE 1SS119		Q303	8-729-119-78	TRANSISTOR 2SC2785-HFE	
D209	8-719-901-83	DIODE 1SS83		Q304	8-729-119-78	TRANSISTOR 2SC2785-HFE	
D210	8-719-300-80	DIODE RU-C		Q305	8-729-384-48	TRANSISTOR 2SA844-E	
D211	8-719-300-80	DIODE RU-C		Q306	8-729-804-63	TRANSISTOR 2SA1406-E	
D212	8-719-911-19	DIODE 1SS119		Q307	8-729-804-58	TRANSISTOR 2SC3600-E	
D213	8-719-911-19	DIODE 1SS119		Q308	8-729-804-58	TRANSISTOR 2SC3600-E	
D214	8-719-911-19	DIODE 1SS119		Q309	8-729-804-63	TRANSISTOR 2SA1406-E	
D215	8-719-911-19	DIODE 1SS119		Q310	8-729-804-58	TRANSISTOR 2SC3600-E	
D216	8-719-911-19	DIODE 1SS119		Q311	8-729-804-63	TRANSISTOR 2SA1406-E	
D301	8-719-911-19	DIODE 1SS119		Q312	8-729-255-12	TRANSISTOR 2SC2551-O	
D302	8-719-911-19	DIODE 1SS119		Q313	8-729-119-78	TRANSISTOR 2SC2785-HFE	
D303	8-719-911-19	DIODE 1SS119		Q314	8-729-119-78	TRANSISTOR 2SC2785-HFE	
D304	8-719-911-19	DIODE 1SS119		Q315	8-729-119-78	TRANSISTOR 2SC2785-HFE	
D305	8-719-911-19	DIODE 1SS119					
D306	8-719-911-19	DIODE 1SS119					
D307	8-719-911-19	DIODE 1SS119					
D308	8-719-911-19	DIODE 1SS119					
D309	8-719-901-83	DIODE 1SS83					
D310	8-719-300-80	DIODE RU-C					
D311	8-719-300-80	DIODE RU-C					
D312	8-719-911-19	DIODE 1SS119					
D313	8-719-911-19	DIODE 1SS119					
D314	8-719-911-19	DIODE 1SS119					
D315	8-719-911-19	DIODE 1SS119					
D316	8-719-911-19	DIODE 1SS119					
		<u>IC</u>					
IC1	8-759-945-58	IC RC4558P					
		<u>TRANSISTOR</u>					
Q1	8-729-384-48	TRANSISTOR 2SA844-E		R1	1-249-429-11	CARBON 10K 5%	1/4W
Q12	8-729-200-17	TRANSISTOR 2SA1091-O		R2	1-249-441-11	CARBON 100K 5%	1/4W
Q13	8-729-200-17	TRANSISTOR 2SA1091-O		R3	1-249-417-11	CARBON 1K 5%	1/4W
Q101	8-729-266-82	TRANSISTOR 2SC2668-B		R10	1-215-878-00	METAL OXIDE 33K 5%	1W
Q102	8-729-384-48	TRANSISTOR 2SA844-E		R11	1-249-439-11	CARBON 68K 5%	1/4W
Q103	8-729-119-78	TRANSISTOR 2SC2785-HFE		R12	1-249-417-11	CARBON 1K 5%	1/4W
Q104	8-729-119-78	TRANSISTOR 2SC2785-HFE		R13	1-249-429-11	CARBON 10K 5%	1/4W
Q105	8-729-384-48	TRANSISTOR 2SA844-E		R14	1-215-469-00	METAL 100K 1%	1/6W
Q106	8-729-804-63	TRANSISTOR 2SA1406-E		R15	1-215-461-00	METAL 47K 1%	1/6W
Q107	8-729-804-58	TRANSISTOR 2SC3600-E		R16	1-215-447-00	METAL 12K 1%	1/6W
Q108	8-729-804-58	TRANSISTOR 2SC3600-E		R101	1-215-391-00	METAL 56 1%	1/6W
Q109	8-729-804-63	TRANSISTOR 2SA1406-E		R102	1-249-419-11	CARBON 1.5K 5%	1/4W
Q110	8-729-804-58	TRANSISTOR 2SC3600-E		R104	1-249-405-11	CARBON 100 5%	1/4W
Q111	8-729-804-63	TRANSISTOR 2SA1406-E		R105	1-249-424-11	CARBON 3.9K 5%	1/4W
Q112	8-729-255-12	TRANSISTOR 2SC2551-O		R106	1-249-422-11	CARBON 2.7K 5%	1/4W
Q113	8-729-119-78	TRANSISTOR 2SC2785-HFE		R107	1-249-405-11	CARBON 100 5%	1/4W
Q114	8-729-119-78	TRANSISTOR 2SC2785-HFE		R108	1-249-405-11	CARBON 100 5%	1/4W
Q115	8-729-119-78	TRANSISTOR 2SC2785-HFE		R109	1-249-421-11	CARBON 2.2K 5%	1/4W
Q201	8-729-266-82	TRANSISTOR 2SC2668-B		R110	1-249-405-11	CARBON 100 5%	1/4W
Q202	8-729-384-48	TRANSISTOR 2SA844-E		R111	1-249-405-11	CARBON 100 5%	1/4W
Q203	8-729-119-78	TRANSISTOR 2SC2785-HFE		R112	1-215-391-00	METAL 56 1%	1/6W
Q204	8-729-119-78	TRANSISTOR 2SC2785-HFE		R113	1-215-391-00	METAL 56 1%	1/6W
Q205	8-729-384-48	TRANSISTOR 2SA844-E		R114	1-215-437-00	METAL 4.7K 1%	1/6W
Q206	8-729-804-63	TRANSISTOR 2SA1406-E		R115	1-214-765-00	METAL 33K 1%	1/4W
Q207	8-729-804-58	TRANSISTOR 2SC3600-E		R116	1-214-765-00	METAL 33K 1%	1/4W
Q208	8-729-804-58	TRANSISTOR 2SC3600-E		R117	1-249-405-11	CARBON 100 5%	1/4W
Q209	8-729-804-63	TRANSISTOR 2SA1406-E		R118	1-214-781-00	METAL 150K 1%	1/4W
Q210	8-729-804-58	TRANSISTOR 2SC3600-E		R119	1-215-447-00	METAL 12K 1%	1/6W
Q211	8-729-804-63	TRANSISTOR 2SA1406-E		R120	1-216-431-11	METAL OXIDE 560 5%	1W
				R121	1-249-405-11	CARBON 100 5%	1/4W
				R122	1-249-405-11	CARBON 100 5%	1/4W
				R123	1-215-405-00	METAL 220 1%	1/6W
				R124	1-249-405-11	CARBON 100 5%	1/4W
				R125	1-249-405-11	CARBON 100 5%	1/4W
				R126	1-215-394-00	METAL 75 1%	1/6W
				R127	1-215-394-00	METAL 75 1%	1/6W
				R128	1-214-779-00	METAL 120K 1%	1/4W
				R129	1-249-430-11	CARBON 12K 5%	1/4W
				R130	1-216-443-11	METAL OXIDE 56K 5%	1W
				R131	1-249-433-11	CARBON 22K 5%	1/4W
				R132	1-249-422-11	CARBON 2.7K 5%	1/4W
				R133	1-249-435-11	CARBON 33K 5%	1/4W
				R134	1-249-433-11	CARBON 22K 5%	1/4W
				R135	1-249-426-11	CARBON 5.6K 5%	1/4W
				R136	1-249-423-11	CARBON 3.3K 5%	1/4W

BK C

The components identified by shading and mark **△** are critical for safety.
Replace only with part number specified.

Ref.No	Part No.	Description	Remark
R137	1-247-903-00	CARBON 1M 5%	1/4W
R138	1-249-426-11	CARBON 5.6K 5%	1/4W
R139	1-215-441-00	METAL 6.8K 1%	1/6W
R140	1-249-405-11	CARBON 100 5%	1/4W
R141	1-249-413-11	CARBON 470 5%	1/4W
R142	1-249-390-11	CARBON 5.6 5%	1/4W
R143	1-249-422-11	CARBON 2.7K 5%	1/4W
R201	1-215-391-00	METAL 56 1%	1/6W
R202	1-249-419-11	CARBON 1.5K 5%	1/4W
R204	1-249-405-11	CARBON 100 5%	1/4W
R205	1-249-424-11	CARBON 3.9K 5%	1/4W
R206	1-249-422-11	CARBON 2.7K 5%	1/4W
R207	1-249-405-11	CARBON 100 5%	1/4W
R208	1-249-405-11	CARBON 100 5%	1/4W
R209	1-249-421-11	CARBON 2.2K 5%	1/4W
R210	1-249-405-11	CARBON 100 5%	1/4W
R211	1-249-405-11	CARBON 100 5%	1/4W
R212	1-215-391-00	METAL 56 1%	1/6W
R213	1-215-391-00	METAL 56 1%	1/6W
R214	1-215-437-00	METAL 4.7K 1%	1/6W
R215	1-214-765-00	METAL 33K 1%	1/4W
R216	1-214-765-00	METAL 33K 1%	1/4W
R217	1-249-405-11	CARBON 100 5%	1/4W
R218	1-214-781-00	METAL 150K 1%	1/4W
R219	1-215-447-00	METAL 12K 1%	1/6W
R220	1-216-431-11	METAL OXIDE 560 5%	1W F
R221	1-249-405-11	CARBON 100 5%	1/4W
R222	1-249-405-11	CARBON 100 5%	1/4W
R223	1-215-405-00	METAL 220 1%	1/6W
R224	1-249-405-11	CARBON 100 5%	1/4W
R225	1-249-405-11	CARBON 100 5%	1/4W
R226	1-215-394-00	METAL 75 1%	1/6W
R227	1-215-394-00	METAL 75 1%	1/6W
R228	1-214-779-00	METAL 120K 1%	1/4W
R229	1-249-430-11	CARBON 12K 5%	1/4W
R230	1-216-443-11	METAL OXIDE 56K 5%	1W F
R231	1-249-433-11	CARBON 22K 5%	1/4W
R232	1-249-422-11	CARBON 2.7K 5%	1/4W
R233	1-249-435-11	CARBON 33K 5%	1/4W
R234	1-249-433-11	CARBON 22K 5%	1/4W
R235	1-249-426-11	CARBON 5.6K 5%	1/4W
R236	1-249-423-11	CARBON 3.3K 5%	1/4W
R237	1-247-903-00	CARBON 1M 5%	1/4W
R238	1-249-426-11	CARBON 5.6K 5%	1/4W
R239	1-215-441-00	METAL 6.8K 1%	1/6W
R240	1-249-405-11	CARBON 100 5%	1/4W
R241	1-249-413-11	CARBON 470 5%	1/4W
R242	1-249-390-11	CARBON 5.6 5%	1/4W
R243	1-249-422-11	CARBON 2.7K 5%	1/4W
R301	1-215-391-00	METAL 56 1%	1/6W
R302	1-249-419-11	CARBON 1.5K 5%	1/4W
R304	1-249-405-11	CARBON 100 5%	1/4W
R305	1-249-424-11	CARBON 3.9K 5%	1/4W
R306	1-249-422-11	CARBON 2.7K 5%	1/4W
R307	1-249-405-11	CARBON 100 5%	1/4W
R308	1-249-405-11	CARBON 100 5%	1/4W
R309	1-249-421-11	CARBON 2.2K 5%	1/4W
R310	1-249-405-11	CARBON 100 5%	1/4W
R311	1-249-405-11	CARBON 100 5%	1/4W
R312	1-215-391-00	METAL 56 1%	1/6W
R313	1-215-391-00	METAL 56 1%	1/6W
R314	1-215-437-00	METAL 4.7K 1%	1/6W
R315	1-214-765-00	METAL 33K 1%	1/4W
R316	1-214-765-00	METAL 33K 1%	1/4W
R317	1-249-405-11	CARBON 100 5%	1/4W

Ref.No	Part No.	Description	Remark
R318	1-214-781-00	METAL 150K 1%	1/4W
R319	1-215-447-00	METAL 12K 1%	1/6W
R320	1-216-431-11	METAL OXIDE 560 5%	1W F
R321	1-249-405-11	CARBON 100 5%	1/4W
R322	1-249-405-11	CARBON 100 5%	1/4W
R323	1-215-405-00	METAL 220 1%	1/6W
R324	1-249-405-11	CARBON 100 5%	1/4W
R325	1-249-405-11	CARBON 100 5%	1/4W
R326	1-215-394-00	METAL 75 1%	1/6W
R327	1-215-394-00	METAL 75 1%	1/6W
R328	1-214-779-00	METAL 120K 1%	1/4W
R329	1-249-430-11	CARBON 12K 5%	1/4W
R330	1-216-443-11	METAL OXIDE 56K 5%	1W F
R331	1-249-433-11	CARBON 22K 5%	1/4W
R332	1-249-422-11	CARBON 2.7K 5%	1/4W
R333	1-249-435-11	CARBON 33K 5%	1/4W
R334	1-249-433-11	CARBON 22K 5%	1/4W
R335	1-249-426-11	CARBON 5.6K 5%	1/4W
R336	1-249-423-11	CARBON 3.3K 5%	1/4W
R337	1-247-903-00	CARBON 1M 5%	1/4W
R338	1-249-426-11	CARBON 5.6K 5%	1/4W
R339	1-215-441-00	METAL 6.8K 1%	1/6W
R340	1-249-405-11	CARBON 100 5%	1/4W
R341	1-249-413-11	CARBON 470 5%	1/4W
R342	1-249-390-11	CARBON 5.6 5%	1/4W
R343	1-249-422-11	CARBON 2.7K 5%	1/4W

*1-617-889-11 C BOARD

△1-526-771-11 SOCKET, CRT
1-556-880-81 LEAD ASSY, HIGH-VOLTAGE

CAPACITOR

C1	1-162-114-00	CERAMIC	0.0047MF	2KV
C2	1-162-114-00	CERAMIC	0.0047MF	2KV

CONNECTOR

C1	*1-566-054-11	PIN, CONNECTOR 2P
C2	*1-566-056-11	PIN, CONNECTOR 4P
C3	*1-566-054-11	PIN, CONNECTOR 2P
C4	*1-566-056-11	PIN, CONNECTOR 4P
C5	*1-566-054-11	PIN, CONNECTOR 2P
C6	*1-566-056-11	PIN, CONNECTOR 4P
C7	*1-508-765-00	3P PLUG (M)
C8	*1-508-786-00	2P PLUG (M)

COIL

L1	1-408-408-00	INDUCTOR	8.2UH
L2	1-408-408-00	INDUCTOR	8.2UH
L3	1-408-408-00	INDUCTOR	8.2UH

RESISTOR

R1	1-202-818-00	SOLID	1K	10%	1/2W
R2	1-202-818-00	SOLID	1K	10%	1/2W
R3	1-202-818-00	SOLID	1K	10%	1/2W
R4	1-249-431-11	CARBON	15K	5%	1/4W
R5	1-202-818-00	SOLID	1K	10%	1/2W
R6	1-202-818-00	SOLID	1K	10%	1/2W
R7	1-202-818-00	SOLID	1K	10%	1/2W
R8	1-249-431-11	CARBON	15K	5%	1/4W
R9	1-202-818-00	SOLID	1K	10%	1/2W
R10	1-202-818-00	SOLID	1K	10%	1/2W
R11	1-202-818-00	SOLID	1K	10%	1/2W

Ref.No	Part No.	Description	Remark		
R12	1-249-431-11	CARBON	15K	5%	1/4W
R13	1-202-818-00	SOLID	1K	10%	1/2W
<u>SPARK GAP</u>					
SG1	1-519-063-XX	DISCHARGING GAP			
SG2	1-519-063-XX	DISCHARGING GAP			
SG3	1-519-063-XX	DISCHARGING GAP			
SG4	1-519-063-XX	DISCHARGING GAP			
SG5	1-519-063-XX	DISCHARGING GAP			
SG6	1-519-063-XX	DISCHARGING GAP			
SG7	1-519-063-XX	DISCHARGING GAP			

*A-1345-767-A DA BOARD, COMPLETE *****					
3-618-225-00 NUT, PLATE					
7-682-548-04 SCREW P 3X8					
<u>CAPACITOR</u>					
C1	1-126-157-11	ELECT	10MF	20%	16V
C2	1-126-157-11	ELECT	10MF	20%	16V
C3	1-161-051-00	CERAMIC	0.01MF	10%	50V
C4	1-101-361-00	CERAMIC	150PF	5%	50V
C5	1-161-051-00	CERAMIC	0.01MF	10%	50V
C6	1-161-051-00	CERAMIC	0.01MF	10%	50V
C7	1-101-361-00	CERAMIC	150PF	5%	50V
C8	1-102-971-00	CERAMIC	82PF	5%	50V
C9	1-101-361-00	CERAMIC	150PF	5%	50V
C10	1-106-188-	MYLAR	0.0047MF	5%	100V
C11	1-130-738-00	FILM	0.015MF	5%	100V
C12	1-136-157-00	FILM	0.022MF	5%	50V
C13	1-136-155-00	FILM	0.015MF	5%	50V
C14	1-136-157-00	FILM	0.022MF	5%	50V
C15	1-130-479-00	MYLAR	0.0047MF	5%	50V
C16	1-124-589-11	ELECT	47MF	20%	16V
C17	1-124-234-00	ELECT	22MF	20%	16V
C18	1-124-234-00	ELECT	22MF	20%	16V
C19	1-161-051-00	CERAMIC	0.01MF	10%	50V
C20	1-130-871-11	FILM	0.01MF	5%	50V
C21	1-126-301-11	ELECT	1MF	20%	50V
C22	1-130-871-11	FILM	0.01MF	5%	50V
C23	1-126-301-11	ELECT	1MF	20%	50V
C24	1-126-301-11	ELECT	1MF	20%	50V
C25	1-126-301-11	ELECT	1MF	20%	50V
C26	1-161-051-00	CERAMIC	0.01MF	10%	50V
C27	1-126-157-11	ELECT	10MF	20%	16V
C28	1-126-157-11	ELECT	10MF	20%	16V
C29	1-126-301-11	ELECT	1MF	20%	50V
C30	1-161-051-00	CERAMIC	0.01MF	10%	50V
C31	1-102-973-00	CERAMIC	100PF	5%	50V
C32	1-101-361-00	CERAMIC	150PF	5%	50V
C33	1-130-871-11	FILM	0.01MF	5%	50V
C34	1-126-301-11	ELECT	1MF	20%	50V
C35	1-161-051-00	CERAMIC	0.01MF	10%	50V
C36	1-102-824-00	CERAMIC	470PF	5%	50V
C38	1-102-824-00	CERAMIC	470PF	5%	50V
C39	1-161-051-00	CERAMIC	0.01MF	10%	50V
C40	1-130-871-11	FILM	0.01MF	5%	50V
C41	1-126-301-11	ELECT	1MF	20%	50V
C42	1-130-871-11	FILM	0.01MF	5%	50V
C43	1-126-301-11	ELECT	1MF	20%	50V
C44	1-124-465-00	ELECT	0.47MF	20%	50V
C45	1-126-157-11	ELECT	10MF	20%	16V
C46	1-126-157-11	ELECT	10MF	20%	16V

Ref.No	Part No.	Description	Remark		
C47	1-161-051-00	CERAMIC	0.01MF	10%	50V
C48	1-161-051-00	CERAMIC	0.01MF	10%	50V
C49	1-161-051-00	CERAMIC	0.01MF	10%	50V
C50	1-161-051-00	CERAMIC	0.01MF	10%	50V
C51	1-161-051-00	CERAMIC	0.01MF	10%	50V
C52	1-161-051-00	CERAMIC	0.01MF	10%	50V
C53	1-161-051-00	CERAMIC	0.01MF	10%	50V
C54	1-126-157-11	ELECT	10MF	20%	16V
C55	1-126-157-11	ELECT	10MF	20%	16V
C56	1-161-051-00	CERAMIC	0.01MF	10%	50V
C57	1-136-474-11	FILM	0.1MF	5%	100V
C58	1-130-871-11	FILM	0.01MF	5%	50V
C59	1-161-051-00	CERAMIC	0.01MF	10%	50V
C60	1-130-871-11	FILM	0.01MF	5%	50V
C61	1-161-051-00	CERAMIC	0.01MF	10%	50V
C62	1-130-871-11	FILM	0.01MF	5%	50V
C63	1-161-051-00	CERAMIC	0.01MF	10%	50V
C64	1-130-871-11	FILM	0.01MF	5%	50V
C65	1-161-051-00	CERAMIC	0.01MF	10%	50V
C66	1-161-051-00	CERAMIC	0.01MF	10%	50V
C67	1-126-163-11	ELECT	4.7MF	20%	25V
C68	1-101-361-00	CERAMIC	150PF	5%	50V
C69	1-126-157-11	ELECT	10MF	20%	16V
C70	1-126-157-11	ELECT	10MF	20%	16V
C71	1-126-157-11	ELECT	10MF	20%	16V
C72	1-126-157-11	ELECT	10MF	20%	16V
C73	1-161-051-00	CERAMIC	0.01MF	10%	50V
C74	1-126-157-11	ELECT	10MF	20%	16V
C75	1-126-157-11	ELECT	10MF	20%	16V
C76	1-136-165-00	FILM	0.1MF	5%	50V
C77	1-136-165-00	FILM	0.1MF	5%	50V
C78	1-161-051-00	CERAMIC	0.01MF	10%	50V
C80	1-101-004-00	CERAMIC	0.01MF	50V	
C90	1-136-161-00	FILM	0.047MF	5%	50V
C100	1-136-165-00	FILM	0.1MF	5%	50V
C101	1-136-165-00	FILM	0.1MF	5%	50V
C102	1-102-978-00	CERAMIC	220PF	5%	50V
<u>DIODE</u>					
D1	8-719-911-19	DIODE 1SS119			
D2	8-719-911-19	DIODE 1SS119			
D3	8-719-109-97	DIODE RD6.8ES-B2			
D4	8-719-109-97	DIODE RD6.8ES-B2			
D5	8-719-110-31	DIODE RD12ES-B2			
D6	8-719-110-31	DIODE RD12ES-B2			
D7	8-719-911-19	DIODE 1SS119			
D8	8-719-911-19	DIODE 1SS119			
D9	8-719-110-03	DIODE RD7.5ES-B2			
D10	8-719-110-03	DIODE RD7.5ES-B2			
D11	8-719-110-41	DIODE RD15ESB2			
D12	8-719-109-89	DIODE RD5.6ESB2			
D13	8-719-911-19	DIODE 1SS119			
D14	8-719-911-19	DIODE 1SS119			
D15	8-719-911-19	DIODE 1SS119			
D18	8-719-911-19	DIODE 1SS119			
D19	8-719-911-19	DIODE 1SS119			
<u>CONNECTOR</u>					
DA1	*1-566-060-11	PIN, CONNECTOR 8P			
DA2	*1-566-056-11	PIN, CONNECTOR 4P			
DA3	*1-566-062-11	PIN, CONNECTOR 10P			
DA4	*1-566-058-11	PIN, CONNECTOR 6P			
DA5	*1-566-055-11	PIN, CONNECTOR 3P			
DA6	*1-566-058-11	PIN, CONNECTOR 6P			
DA7	*1-566-056-11	PIN, CONNECTOR 4P			

Ref.No	Part No.	Description	Remark	Ref.No	Part No.	Description	Remark
<u>IC</u>				R8	1-249-417-11	CARBON	1K 5% 1/4W
IC1	8-759-984-27	IC MB84027B		R9	1-249-417-11	CARBON	1K 5% 1/4W
IC2	8-759-040-11	IC MC14011BCP		R10	1-249-423-11	CARBON	3.3K 5% 1/4W
IC3	8-759-000-58	IC MC14093BCP		R11	1-249-419-11	CARBON	1.5K 5% 1/4W
IC4	8-751-580-00	IC CX-158		R12	1-249-429-11	CARBON	10K 5% 1/4W
IC5	8-759-990-82	IC TL082CP		R13	1-249-424-11	CARBON	3.9K 5% 1/4W
IC6	8-759-990-82	IC TL082CP		R14	1-249-419-11	CARBON	1.5K 5% 1/4W
IC7	8-759-014-96	IC MC1496P		R15	1-249-410-11	CARBON	270 5% 1/4W
IC8	8-759-981-64	IC LM2903DQ		R16	1-249-417-11	CARBON	1K 5% 1/4W
IC9	8-759-990-82	IC TL082CP		R17	1-215-427-00	METAL	1.8K 1% 1/6W
IC10	8-759-981-64	IC LM2903DQ		R18	1-215-435-00	METAL	3.9K 1% 1/6W
IC11	8-759-990-82	IC TL082CP		R19	1-215-443-00	METAL	8.2K 1% 1/6W
IC12	8-759-014-96	IC MC1496P		R20	1-249-400-11	CARBON	39 5% 1/4W
IC13	8-759-000-49	IC MC14066BCP		R21	1-249-429-11	CARBON	10K 5% 1/4W
IC14	8-759-000-49	IC MC14066BCP		R22	1-215-445-00	METAL	10K 1% 1/6W
IC15	8-759-000-49	IC MC14066BCP		R23	1-249-429-11	CARBON	10K 5% 1/4W
IC16	8-759-000-49	IC MC14066BCP		R24	1-249-427-11	CARBON	6.8K 5% 1/4W
IC17	8-759-945-58	IC RC4558DQ		R25	1-249-393-11	CARBON	10 5% 1/4W
IC18	8-759-909-70	IC CX23025		R26	1-215-439-00	METAL	5.6K 1% 1/6W
IC19	8-759-945-58	IC RC4558DQ		R27	1-249-429-11	CARBON	10K 5% 1/4W
IC20	8-759-945-58	IC RC4558DQ		R28	1-215-421-00	METAL	1K 1% 1/6W
IC21	8-759-945-58	IC RC4558DQ		R29	1-215-458-00	METAL	36K 1% 1/6W
IC22	8-759-945-58	IC RC4558DQ		R30	1-249-429-11	CARBON	10K 5% 1/4W
IC23	8-759-945-58	IC RC4558DQ		R31	1-249-427-11	CARBON	6.8K 5% 1/4W
IC24	8-759-929-62	IC LM7812CT		R32	1-249-393-11	CARBON	10 5% 1/4W
IC25	8-759-929-65	IC LM7912CT		R33	1-247-848-11	CARBON	5.1K 5% 1/4W
IC26	8-759-990-82	IC TL082CP		R34	1-249-424-11	CARBON	3.9K 5% 1/4W
<u>COIL</u>				R35	1-247-800-11	CARBON	51 5% 1/4W
L1	1-407-504-00	INDUCTOR 10MMH		R36	1-249-417-11	CARBON	1K 5% 1/4W
<u>TRANSISTOR</u>				R37	1-249-417-11	CARBON	1K 5% 1/4W
Q1	8-729-900-89	TRANSISTOR DTC144ES		R38	1-249-417-11	CARBON	1K 5% 1/4W
Q2	8-729-119-78	TRANSISTOR 2SC2785-HFE		R39	1-249-417-11	CARBON	1K 5% 1/4W
Q3	8-729-119-78	TRANSISTOR 2SC2785-HFE		R40	1-249-417-11	CARBON	1K 5% 1/4W
Q4	8-729-119-78	TRANSISTOR 2SC2785-HFE		R41	1-247-800-11	CARBON	51 5% 1/4W
Q5	8-729-119-78	TRANSISTOR 2SC2785-HFE		R42	1-249-430-11	CARBON	12K 5% 1/4W
Q6	8-729-119-78	TRANSISTOR 2SC2785-HFE		R43	1-249-419-11	CARBON	1.5K 5% 1/4W
Q7	8-729-119-78	TRANSISTOR 2SC2785-HFE		R44	1-249-424-11	CARBON	3.9K 5% 1/4W
Q8	8-729-119-78	TRANSISTOR 2SC2785-HFE		R45	1-249-429-11	CARBON	10K 5% 1/4W
Q9	8-729-800-10	TRANSISTOR 2SC3068		R46	1-249-429-11	CARBON	10K 5% 1/4W
Q10	8-729-119-78	TRANSISTOR 2SC2785-HFE		R47	1-249-431-11	CARBON	15K 5% 1/4W
Q12	8-729-900-89	TRANSISTOR DTC144ES-HFE		R48	1-249-429-11	CARBON	10K 5% 1/4W
Q13	8-729-900-89	TRANSISTOR DTC144ES-HFE		R49	1-249-429-11	CARBON	10K 5% 1/4W
Q14	8-729-900-89	TRANSISTOR DTC144ES-HFE		R50	1-249-429-11	CARBON	10K 5% 1/4W
Q15	8-729-900-89	TRANSISTOR DTC144ES-HFE		R51	1-249-429-11	CARBON	10K 5% 1/4W
Q16	8-729-900-89	TRANSISTOR DTC144ES-HFE		R52	1-249-417-11	CARBON	1K 5% 1/4W
Q17	8-729-900-89	TRANSISTOR DTC144ES-HFE		R53	1-247-903-00	CARBON	1M 5% 1/4W
Q18	8-729-119-78	TRANSISTOR 2SC2785-HFE		R54	1-249-421-11	CARBON	2.2K 5% 1/4W
Q19	8-729-119-78	TRANSISTOR 2SC2785-HFE		R55	1-249-417-11	CARBON	1K 5% 1/4W
Q20	8-729-119-78	TRANSISTOR 2SC2785-HFE		R56	1-249-435-11	CARBON	33K 5% 1/4W
Q21	8-729-119-78	TRANSISTOR 2SC2785-HFE		R57	1-249-429-11	CARBON	10K 5% 1/4W
Q22	8-729-119-78	TRANSISTOR 2SC2785-HFE		R58	1-249-423-11	CARBON	3.3K 5% 1/4W
Q23	8-729-119-78	TRANSISTOR 2SC2785-HFE		R59	1-249-429-11	CARBON	10K 5% 1/4W
Q24	8-729-119-78	TRANSISTOR 2SC2785-HFE		R60	1-215-445-00	METAL	10K 1% 1/6W
<u>RESISTOR</u>				R61	1-249-429-11	CARBON	10K 5% 1/4W
R1	1-215-461-00	METAL	47K 1% 1/6W	R62	1-249-427-11	CARBON	6.8K 5% 1/4W
R2	1-249-417-11	CARBON	1K 5% 1/4W	R63	1-249-393-11	CARBON	10 5% 1/4W
R3	1-249-430-11	CARBON	12K 5% 1/4W	R64	1-249-429-11	CARBON	10K 5% 1/4W
R4	1-249-417-11	CARBON	1K 5% 1/4W	R65	1-249-433-11	CARBON	22K 5% 1/4W
R5	1-249-422-11	CARBON	2.7K 5% 1/4W	R66	1-249-433-11	CARBON	22K 5% 1/4W
R6	1-247-840-00	CARBON	2.4K 5% 1/4W	R67	1-249-429-11	CARBON	10K 5% 1/4W
R7	1-215-462-00	METAL	51K 1% 1/6W	R68	1-247-903-00	CARBON	1M 5% 1/4W
				R69	1-249-421-11	CARBON	2.2K 5% 1/4W
				R70	1-249-435-11	CARBON	33K 5% 1/4W
				R71	1-249-429-11	CARBON	10K 5% 1/4W
				R72	1-249-423-11	CARBON	3.3K 5% 1/4W



Ref.No	Part No.	Description	Remark
R74	1-249-429-11	CARBON	10K 5% 1/4W
R76	1-249-433-11	CARBON	22K 5% 1/4W
R77	1-249-439-11	CARBON	68K 5% 1/4W
R79	1-249-421-11	CARBON	2.2K 5% 1/4W
R80	1-249-435-11	CARBON	33K 5% 1/4W
R81	1-249-429-11	CARBON	10K 5% 1/4W
R82	1-249-423-11	CARBON	3.3K 5% 1/4W
R83	1-249-429-11	CARBON	10K 5% 1/4W
R84	1-215-445-00	METAL	10K 1% 1/6W
R85	1-249-427-11	CARBON	6.8K 5% 1/4W
R86	1-249-429-11	CARBON	10K 5% 1/4W
R87	1-249-393-11	CARBON	10 5% 1/4W
R88	1-249-429-11	CARBON	10K 5% 1/4W
R89	1-249-429-11	CARBON	10K 5% 1/4W
R90	1-249-417-11	CARBON	1K 5% 1/4W
R91	1-249-429-11	CARBON	10K 5% 1/4W
R92	1-249-435-11	CARBON	33K 5% 1/4W
R93	1-249-393-11	CARBON	10 5% 1/4W
R94	1-247-848-11	CARBON	5.1K 5% 1/4W
R95	1-249-417-11	CARBON	1K 5% 1/4W
R96	1-249-429-11	CARBON	10K 5% 1/4W
R97	1-249-433-11	CARBON	22K 5% 1/4W
R98	1-249-409-11	CARBON	220 5% 1/4W
R99	1-249-405-11	CARBON	100 5% 1/4W
R100	1-249-417-11	CARBON	1K 5% 1/4W
R101	1-249-405-11	CARBON	100 5% 1/4W
R102	1-249-430-11	CARBON	12K 5% 1/4W
R103	1-249-424-11	CARBON	3.9K 5% 1/4W
R104	1-247-800-11	CARBON	51 5% 1/4W
R105	1-249-417-11	CARBON	1K 5% 1/4W
R106	1-249-417-11	CARBON	1K 5% 1/4W
R107	1-249-424-11	CARBON	3.9K 5% 1/4W
R109	1-249-437-11	CARBON	47K 5% 1/4W
R110	1-249-430-11	CARBON	12K 5% 1/4W
R111	1-249-437-11	CARBON	47K 5% 1/4W
R112	1-249-426-11	CARBON	5.6K 5% 1/4W
R113	1-249-430-11	CARBON	12K 5% 1/4W
R114	1-249-437-11	CARBON	47K 5% 1/4W
R115	1-247-830-11	CARBON	910 5% 1/4W
R116	1-247-830-11	CARBON	910 5% 1/4W
R117	1-215-445-00	METAL	10K 1% 1/6W
R118	1-215-449-00	METAL	15K 1% 1/6W
R119	1-215-454-00	METAL	24K 1% 1/6W
R120	1-215-437-00	METAL	4.7K 1% 1/6W
R121	1-215-445-00	METAL	10K 1% 1/6W
R122	1-215-421-00	METAL	1K 1% 1/6W
R123	1-215-445-00	METAL	10K 1% 1/6W
R124	1-215-433-00	METAL	3.3K 1% 1/6W
R125	1-215-443-00	METAL	8.2K 1% 1/6W
R126	1-215-437-00	METAL	4.7K 1% 1/6W
R127	1-249-417-11	CARBON	1K 5% 1/4W
R128	1-249-417-11	CARBON	1K 5% 1/4W
R129	1-249-405-11	CARBON	100 5% 1/4W
R130	1-249-429-11	CARBON	10K 5% 1/4W
R131	1-215-445-00	METAL	10K 1% 1/6W
R132	1-215-445-00	METAL	10K 1% 1/6W
R133	1-215-461-00	METAL	47K 1% 1/6W
R134	1-215-447-00	METAL	12K 1% 1/6W
R135	1-249-427-11	CARBON	6.8K 5% 1/4W
R136	1-249-429-11	CARBON	10K 5% 1/4W
R137	1-249-405-11	CARBON	100 5% 1/4W
R138	1-249-417-11	CARBON	1K 5% 1/4W
R139	1-249-417-11	CARBON	1K 5% 1/4W
R140	1-215-421-00	METAL	1K 1% 1/6W
R141	1-249-429-11	CARBON	10K 5% 1/4W

Ref.No	Part No.	Description	Remark
R142	1-215-457-00	METAL	33K 1% 1/6W
R143	1-215-457-00	METAL	33K 1% 1/6W
R144	1-249-429-11	CARBON	10K 5% 1/4W
R145	1-215-481-00	METAL	330K 1% 1/6W
R146	1-249-429-11	CARBON	10K 5% 1/4W
R147	1-249-433-11	CARBON	22K 5% 1/4W
R148	1-249-405-11	CARBON	100 5% 1/4W
R149	1-215-421-00	METAL	1K 1% 1/6W
R150	1-215-457-00	METAL	33K 1% 1/6W
R151	1-215-457-00	METAL	33K 1% 1/6W
R152	1-215-481-00	METAL	330K 1% 1/6W
R153	1-215-433-00	METAL	3.3K 1% 1/6W
R154	1-215-411-00	METAL	390 1% 1/6W
R155	1-249-429-11	CARBON	10K 5% 1/4W
R156	1-249-429-11	CARBON	10K 5% 1/4W
R157	1-249-433-11	CARBON	22K 5% 1/4W
R158	1-249-405-11	CARBON	100 5% 1/4W
R159	1-249-429-11	CARBON	10K 5% 1/4W
R160	1-247-897-11	CARBON	560K 5% 1/4W
R161	1-215-455-00	METAL	27K 1% 1/6W
R162	1-215-445-00	METAL	10K 1% 1/6W
R163	1-215-445-00	METAL	10K 1% 1/6W
R164	1-215-461-00	METAL	47K 1% 1/6W
R165	1-215-461-00	METAL	47K 1% 1/6W
R166	1-215-485-00	METAL	470K 1% 1/6W
R167	1-249-429-11	CARBON	10K 5% 1/4W
R168	1-249-429-11	CARBON	10K 5% 1/4W
R169	1-249-433-11	CARBON	22K 5% 1/4W
R170	1-249-405-11	CARBON	100 5% 1/4W
R171	1-249-429-11	CARBON	10K 5% 1/4W
R172	1-215-445-00	METAL	10K 1% 1/6W
R173	1-215-445-00	METAL	10K 1% 1/6W
R174	1-215-457-00	METAL	33K 1% 1/6W
R175	1-215-457-00	METAL	33K 1% 1/6W
R176	1-215-481-00	METAL	330K 1% 1/6W
R177	1-249-429-11	CARBON	10K 5% 1/4W
R178	1-247-903-00	CARBON	1M 5% 1/4W
R179	1-249-429-11	CARBON	10K 5% 1/4W
R180	1-249-433-11	CARBON	22K 5% 1/4W
R181	1-249-405-11	CARBON	100 5% 1/4W
R182	1-215-451-00	METAL	18K 1% 1/6W
R183	1-249-429-11	CARBON	10K 5% 1/4W
R184	1-215-477-00	METAL	220K 1% 1/6W
R185	1-215-445-00	METAL	10K 1% 1/6W
R186	1-215-445-00	METAL	10K 1% 1/6W
R187	1-215-437-00	METAL	4.7K 1% 1/6W
R188	1-215-431-00	METAL	2.7K 1% 1/6W
R189	1-215-409-00	METAL	330 1% 1/6W
R190	1-215-432-00	METAL	3K 1% 1/6W
R191	1-215-409-00	METAL	330 1% 1/6W
R192	1-215-433-00	METAL	3.3K 1% 1/6W
R193	1-249-433-11	CARBON	22K 5% 1/4W
R194	1-249-417-11	CARBON	1K 5% 1/4W
R195	1-249-417-11	CARBON	1K 5% 1/4W
R196	1-249-429-11	CARBON	10K 5% 1/4W
R197	1-249-429-11	CARBON	10K 5% 1/4W
R198	1-215-475-00	METAL	180K 1% 1/6W
R200	1-215-445-00	METAL	10K 1% 1/6W
R201	1-249-429-11	CARBON	10K 5% 1/4W
R202	1-249-429-11	CARBON	10K 5% 1/4W
R203	1-249-429-11	CARBON	10K 5% 1/4W
R204	1-249-429-11	CARBON	10K 5% 1/4W
R205	1-249-437-11	CARBON	47K 5% 1/4W
R206	1-249-417-11	CARBON	1K 5% 1/4W
R207	1-249-433-11	CARBON	22K 5% 1/4W

7. ELECTRICAL PARTS LIST

Ref.No	Part No.	Description	Remark	Ref.No	Part No.	Description	Remark
R208	1-249-437-11	CARBON 47K 5%	1/4W	C18	1-161-051-00	CERAMIC 0.01MF 10%	50V
R209	1-249-429-11	CARBON 10K 5%	1/4W	C19	1-124-589-11	ELECT 47MF 20%	16V
R210	1-249-429-11	CARBON 10K 5%	1/4W	C20	1-124-589-11	ELECT 47MF 20%	16V
R211	1-249-429-11	CARBON 10K 5%	1/4W	C21	1-161-051-00	CERAMIC 0.01MF 10%	50V
R220	1-249-439-11	CARBON 68K 5%	1/4W	C22	1-124-589-11	ELECT 47MF 20%	16V
R221	1-249-428-11	CARBON 8.2K 5%	1/4W	C23	1-136-157-00	FILM 0.022MF 5%	50V
R223	1-249-433-11	CARBON 22K 5%	1/4W	C24	1-136-165-00	FILM 0.1MF 5%	50V
R224	1-249-433-11	CARBON 22K 5%	1/4W	C25	1-136-153-00	FILM 0.01MF 5%	50V
R290	1-215-443-00	METAL 8.2K 1%	1/6W	C26	1-136-161-00	FILM 0.047MF 5%	50V
<u>VARIABLE RESISTOR</u>				C27	1-136-157-00	FILM 0.022MF 5%	50V
RV1	1-237-521-21	RES, ADJ, CERMET 100K		C28	1-136-165-00	FILM 0.1MF 5%	50V
RV2	1-237-522-21	RES, ADJ, CERMET 200K		C29	1-136-153-00	FILM 0.01MF 5%	50V
RV3	1-237-521-21	RES, ADJ, CERMET 100K		C30	1-136-161-00	FILM 0.047MF 5%	50V
RV4	1-237-519-21	RES, ADJ, CERMET 20K		C31	1-124-589-11	ELECT 47MF 20%	16V
RV5	1-237-519-21	RES, ADJ, CERMET 20K		C32	1-161-051-00	CERAMIC 0.01MF 10%	50V
RV6	1-237-518-21	RES, ADJ, CERMET 10K		C33	1-136-153-00	FILM 0.01MF 5%	50V
RV7	1-237-518-21	RES, ADJ, CERMET 10K		C34	1-136-161-00	FILM 0.047MF 5%	50V
RV10	1-237-519-21	RES, ADJ, CERMET 20K		C35	1-102-973-00	CERAMIC 100PF 5%	50V
RV11	1-237-519-21	RES, ADJ, CERMET 20K		C36	1-136-165-00	FILM 0.1MF 5%	50V
RV12	1-237-519-21	RES, ADJ, CERMET 20K		C37	1-136-161-00	FILM 0.047MF 5%	50V
RV13	1-237-519-21	RES, ADJ, CERMET 20K		C38	1-102-074-00	CERAMIC 0.001MF 10%	50V
RV14	1-237-519-21	RES, ADJ, CERMET 20K		C39	1-136-165-00	FILM 0.1MF 5%	50V
RV15	1-237-519-21	RES, ADJ, CERMET 20K		C40	1-102-074-00	CERAMIC 0.001MF 10%	50V
RV16	1-237-519-21	RES, ADJ, CERMET 20K		C41	1-136-153-00	FILM 0.01MF 5%	50V
RV17	1-237-517-21	RES, ADJ, CERMET 5K		C42	1-161-051-00	CERAMIC 0.01MF 10%	50V
RV18	1-237-517-21	RES, ADJ, CERMET 5K		C43	1-124-589-11	ELECT 47MF 20%	16V
RV19	1-237-519-21	RES, ADJ, CERMET 20K		C44	1-124-589-11	ELECT 47MF 20%	16V
RV20	1-237-519-21	RES, ADJ, CERMET 20K		C45	1-102-074-00	CERAMIC 0.001MF 10%	50V
RV21	1-237-519-21	RES, ADJ, CERMET 20K		C46	1-136-161-00	FILM 0.047MF 5%	50V
RV22	1-237-516-21	RES, ADJ, CERMET 2K		C47	1-102-973-00	CERAMIC 100PF 5%	50V
RV23	1-237-516-21	RES, ADJ, CERMET 2K		C48	1-136-165-00	FILM 0.1MF 5%	50V
RV24	1-237-516-21	RES, ADJ, CERMET 2K		C49	1-136-161-00	FILM 0.047MF 5%	50V
RV25	1-237-519-21	RES, ADJ, CERMET 20K		C50	1-102-074-00	CERAMIC 0.001MF 10%	50V
RV26	1-237-519-21	RES, ADJ, CERMET 20K		C51	1-136-161-00	FILM 0.047MF 5%	50V
RV27	1-237-519-21	RES, ADJ, CERMET 20K		C52	1-102-074-00	CERAMIC 0.001MF 10%	50V
RV28	1-237-519-21	RES, ADJ, CERMET 20K		C53	1-101-880-00	CERAMIC 47PF 5%	50V
<u>SWITCH</u>				C54	1-161-051-00	CERAMIC 0.01MF 10%	50V
S1	1-571-908-11	SWITCH, SLIDE		C55	1-124-589-11	ELECT 47MF 20%	16V
*****				C56	1-124-589-11	ELECT 47MF 20%	16V
* A-1345-768-A DB BOARD, COMPLETE *****				C57	1-102-074-00	CERAMIC 0.001MF 10%	50V
3-618-225-00 NUT, PLATE				C58	1-136-161-00	FILM 0.047MF 5%	50V
7-682-548-04 SCREW P 3X8				C59	1-102-973-00	CERAMIC 100PF 5%	50V
<u>CAPACITOR</u>				C60	1-136-165-00	FILM 0.1MF 5%	50V
C3	1-102-963-00	CERAMIC 33PF 5%	50V	C61	1-136-161-00	FILM 0.047MF 5%	50V
C4	1-136-165-00	FILM 0.1MF 5%	50V	C62	1-102-074-00	CERAMIC 0.001MF 10%	50V
C5	1-136-161-00	FILM 0.047MF 5%	50V	C63	1-136-161-00	FILM 0.047MF 5%	50V
C6	1-161-051-00	CERAMIC 0.01MF 10%	50V	C64	1-102-074-00	CERAMIC 0.001MF 10%	50V
C7	1-124-589-11	ELECT 47MF 20%	16V	C65	1-101-880-00	CERAMIC 47PF 5%	50V
C8	1-136-153-00	FILM 0.01MF 5%	50V	C66	1-161-051-00	CERAMIC 0.01MF 10%	50V
C9	1-136-153-00	FILM 0.01MF 5%	50V	C67	1-124-589-11	ELECT 47MF 20%	16V
C10	1-136-161-00	FILM 0.047MF 5%	50V	C68	1-124-589-11	ELECT 47MF 20%	16V
C11	1-102-973-00	CERAMIC 100PF 5%	50V	C69	1-161-051-00	CERAMIC 0.01MF 10%	50V
C12	1-136-165-00	FILM 0.1MF 5%	50V	C70	1-102-074-00	CERAMIC 0.001MF 10%	50V
C13	1-136-161-00	FILM 0.047MF 5%	50V	C71	1-124-589-11	ELECT 47MF 20%	16V
C14	1-102-074-00	CERAMIC 0.001MF 10%	50V	C72	1-126-096-11	ELECT 10MF 20%	25V
C15	1-136-165-00	FILM 0.1MF 5%	50V	C73	1-126-096-11	ELECT 10MF 20%	25V
C16	1-102-074-00	CERAMIC 0.001MF 10%	50V	C74	1-126-096-11	ELECT 10MF 20%	25V
C17	1-136-153-00	FILM 0.01MF 5%	50V	C75	1-126-096-11	ELECT 10MF 20%	25V
C18	1-161-051-00	CERAMIC 0.01MF 10%	50V	C76	1-126-096-11	ELECT 10MF 20%	25V
C19	1-102-121-00	CERAMIC 0.0022MF 5%	50V	C77	1-126-096-11	ELECT 10MF 20%	25V
C20	1-136-167-00	FILM 0.15MF 5%	50V	C78	1-161-051-00	CERAMIC 0.01MF 10%	50V
C21	1-161-051-00	CERAMIC 0.01MF 10%	50V	C81	1-102-121-00	CERAMIC 0.0022MF 5%	50V
C22	1-161-051-00	CERAMIC 0.01MF 10%	50V	C83	1-136-167-00	FILM 0.15MF 5%	50V
C23	1-136-157-00	FILM 0.022MF 5%	50V	C85	1-161-051-00	CERAMIC 0.01MF 10%	50V
C24	1-136-165-00	FILM 0.1MF 5%	50V	C86	1-161-051-00	CERAMIC 0.01MF 10%	50V

Ref.No	Part No.	Description	Remark	Ref.No	Part No.	Description	Remark
C87	1-101-361-00	CERAMIC	150PF 5% 50V	Q24	8-729-106-07	TRANSISTOR 2SK514-H	
C88	1-161-051-00	CERAMIC	0.01MF 10% 50V	Q25	8-729-119-78	TRANSISTOR 2SC2785-HFE	
C89	1-161-051-00	CERAMIC	0.01MF 10% 50V	Q26	8-729-119-78	TRANSISTOR 2SC2785-HFE	
<u>DIODE</u>				Q27	8-729-119-78	TRANSISTOR 2SC2785-HFE	
D2	8-719-110-41	DIODE RD15ES-B2		Q28	8-729-106-07	TRANSISTOR 2SK514-H	
D3	8-719-911-19	DIODE 1SS119		Q29	8-729-119-78	TRANSISTOR 2SC2785-HFE	
D4	8-719-911-19	DIODE 1SS119		Q30	8-729-119-78	TRANSISTOR 2SC2785-HFE	
D5	8-719-911-19	DIODE 1SS119		Q31	8-729-119-78	TRANSISTOR 2SC2785-HFE	
D6	8-719-110-03	DIODE RD7.5ES-B2		Q32	8-729-106-07	TRANSISTOR 2SK514-H	
D7	8-719-110-03	DIODE RD7.5ES-B2		Q33	8-729-119-78	TRANSISTOR 2SC2785-HFE	
D8	8-719-109-97	DIODE RD6.8ES-B2		Q34	8-729-119-76	TRANSISTOR 2SA1175-HFE	
<u>CONNECTOR</u>				Q35	8-729-119-76	TRANSISTOR 2SA1175-HFE	
DB1	*1-566-049-11	PIN, CONNECTOR 10P		Q36	8-729-119-78	TRANSISTOR 2SC2785-HFE	
DB2	*1-566-041-11	PIN, CONNECTOR 2P		Q37	8-729-900-36	TRANSISTOR DTC124ES	
DB3	*1-566-042-11	PIN, CONNECTOR 3P		Q38	8-729-119-76	TRANSISTOR 2SA1175-HFE	
DB4	*1-566-042-11	PIN, CONNECTOR 3P		Q40	8-729-119-78	TRANSISTOR 2SC2785-HFE	
DB5	*1-566-042-11	PIN, CONNECTOR 3P		Q41	8-729-119-78	TRANSISTOR 2SC2785-HFE	
<u>IC</u>				Q42	8-729-201-05	TRANSISTOR 2SC2878-B	
IC1	8-759-945-58	IC RC4558P		Q43	8-729-119-78	TRANSISTOR 2SC2785-HFE	
IC2	8-759-945-58	IC RC4558P		Q44	8-729-119-76	TRANSISTOR 2SA1175-HFE	
IC3	8-759-945-58	IC RC4558P		Q45	8-729-119-78	TRANSISTOR 2SC2785-HFE	
IC4	8-759-945-58	IC RC4558P		Q46	8-729-119-78	TRANSISTOR 2SC2785-HFE	
IC5	8-759-945-58	IC RC4558P		<u>RESISTOR</u>			
IC6	8-759-945-58	IC RC4558P		R3	1-249-423-11	CARBON	33K 5% 1/4W
IC7	8-759-945-58	IC RC4558P		R4	1-249-441-11	CARBON	100K 5% 1/4W
IC8	8-759-945-58	IC RC4558P		R5	1-249-429-11	CARBON	10K 5% 1/4W
IC9	8-759-040-53	IC MC14053BCP		R6	1-249-420-11	CARBON	1.8K 5% 1/4W
IC10	8-759-040-53	IC MC14053BCP		R7	1-249-429-11	CARBON	10K 5% 1/4W
IC11	8-759-040-53	IC MC14053BCP		R8	1-249-429-11	CARBON	10K 5% 1/4W
IC13	8-759-929-62	IC LM7812CT		R9	1-249-425-11	CARBON	4.7K 5% 1/4W
IC14	8-759-929-65	IC LM7912CT		R10	1-215-467-00	METAL	82K 1% 1/6W
IC15	8-759-345-38	IC HD14538BP		R11	1-215-439-00	METAL	5.6K 1% 1/6W
IC16	8-759-981-64	IC LM2903DQ		R12	1-215-477-00	METAL	220K 1% 1/6W
<u>COIL</u>				R13	1-249-429-11	CARBON	10K 5% 1/4W
L1	1-408-238-00	INDUCTOR	3.9MMH	R14	1-249-433-11	CARBON	22K 5% 1/4W
L2	1-408-238-00	INDUCTOR	3.9MMH	R15	1-249-433-11	CARBON	22K 5% 1/4W
L3	1-408-238-00	INDUCTOR	3.9MMH	R16	1-249-441-11	CARBON	100K 5% 1/4W
L4	1-408-238-00	INDUCTOR	3.9MMH	R17	1-249-433-11	CARBON	22K 5% 1/4W
<u>TRANSISTOR</u>				R18	1-215-477-00	METAL	220K 1% 1/6W
Q2	8-729-119-78	TRANSISTOR 2SC2785-HFE		R19	1-249-429-11	CARBON	10K 5% 1/4W
Q3	8-729-119-78	TRANSISTOR 2SC2785-HFE		R20	1-249-433-11	CARBON	22K 5% 1/4W
Q4	8-729-900-36	TRANSISTOR DTC124ES		R21	1-249-433-11	CARBON	22K 5% 1/4W
Q5	8-729-119-78	TRANSISTOR 2SC2785-HFE		R22	1-249-441-11	CARBON	100K 5% 1/4W
Q6	8-729-119-78	TRANSISTOR 2SC2785-HFE		R23	1-249-429-11	CARBON	10K 5% 1/4W
Q7	8-729-201-05	TRANSISTOR 2SC2878-B		R24	1-215-457-00	METAL	33K 1% 1/6W
Q8	8-729-119-78	TRANSISTOR 2SC2785-HFE		R25	1-249-405-11	CARBON	100 5% 1/4W
Q9	8-729-106-07	TRANSISTOR 2SK514-H		R26	1-249-417-11	CARBON	1K 5% 1/4W
Q10	8-729-900-36	TRANSISTOR DTC124ES		R27	1-249-433-11	CARBON	22K 5% 1/4W
Q11	8-729-201-05	TRANSISTOR 2SC2878-B		R28	1-249-425-11	CARBON	4.7K 5% 1/4W
Q12	8-729-201-05	TRANSISTOR 2SC2878-B		R29	1-249-435-11	CARBON	33K 5% 1/4W
Q13	8-729-106-07	TRANSISTOR 2SK514-H		R30	1-249-421-11	CARBON	2.2K 5% 1/4W
Q14	8-729-900-36	TRANSISTOR DTC124ES		R31	1-249-417-11	CARBON	1K 5% 1/4W
Q15	8-729-119-78	TRANSISTOR 2SC2785-HFE		R32	1-249-433-11	CARBON	22K 5% 1/4W
Q16	8-729-106-07	TRANSISTOR 2SK514-H		R33	1-249-425-11	CARBON	4.7K 5% 1/4W
Q17	8-729-900-36	TRANSISTOR DTC124ES		R34	1-247-903-00	CARBON	1M 5% 1/4W
Q18	8-729-119-78	TRANSISTOR 2SC2785-HFE		R35	1-249-429-11	CARBON	10K 5% 1/4W
Q19	8-729-201-05	TRANSISTOR 2SC2878-B		R36	1-249-429-11	CARBON	10K 5% 1/4W
Q20	8-729-201-05	TRANSISTOR 2SC2878-B		R37	1-249-429-11	CARBON	10K 5% 1/4W
Q21	8-729-201-05	TRANSISTOR 2SC2878-B		R38	1-215-445-00	METAL	10K 1% 1/6W
Q22	8-729-119-78	TRANSISTOR 2SC2785-HFE		R39	1-215-445-00	METAL	10K 1% 1/6W
Q23	8-729-119-78	TRANSISTOR 2SC2785-HFE		R40	1-249-429-11	CARBON	10K 5% 1/4W
				R42	1-249-441-11	CARBON	100K 5% 1/4W
				R43	1-249-405-11	CARBON	100 5% 1/4W
				R44	1-249-421-11	CARBON	2.2K 5% 1/4W

Ref.No	Part No.	Description	Remark			Ref.No	Part No.	Description	Remark		
R45	1-215-445-00	METAL	10K	1%	1/6W	R111	1-249-421-11	CARBON	22K	5%	1/4W
R46	1-215-445-00	METAL	10K	1%	1/6W	R112	1-249-405-11	CARBON	100	5%	1/4W
R47	1-249-429-11	CARBON	10K	5%	1/4W	R113	1-249-429-11	CARBON	10K	5%	1/4W
R48	1-247-895-00	CARBON	470K	5%	1/4W	R114	1-215-441-00	METAL	6.8K	1%	1/6W
R49	1-215-451-00	METAL	18K	1%	1/6W	R115	1-215-469-00	METAL	100K	1%	1/6W
R50	1-215-451-00	METAL	18K	1%	1/6W	R116	1-249-421-11	CARBON	22K	5%	1/4W
R51	1-249-429-11	CARBON	10K	5%	1/4W	R117	1-249-405-11	CARBON	100	5%	1/4W
R52	1-215-451-00	METAL	18K	1%	1/6W	R118	1-249-405-11	CARBON	100	5%	1/4W
R53	1-247-895-00	CARBON	470K	5%	1/4W	R120	1-215-421-00	METAL	1K	1%	1/6W
R54	1-215-451-00	METAL	18K	1%	1/6W	R121	1-249-425-11	CARBON	4.7K	5%	1/4W
R55	1-249-429-11	CARBON	10K	5%	1/4W	R122	1-215-461-00	METAL	47K	1%	1/6W
R57	1-249-405-11	CARBON	100	5%	1/4W	R123	1-215-437-00	METAL	4.7K	1%	1/6W
R58	1-249-405-11	CARBON	100	5%	1/4W	R124	1-215-437-00	METAL	4.7K	1%	1/6W
R59	1-249-421-11	CARBON	2.2K	5%	1/4W	R125	1-215-469-00	METAL	100K	1%	1/6W
R60	1-215-445-00	METAL	10K	1%	1/6W	R126	1-249-435-11	CARBON	33K	5%	1/4W
R61	1-249-429-11	CARBON	10K	5%	1/4W	R128	1-202-669-	SOLID	10M	5%	1/2W
R62	1-215-445-00	METAL	10K	1%	1/6W	R129	1-215-479-00	METAL	270K	1%	1/6W
R63	1-215-457-00	METAL	33K	1%	1/6W	R130	1-247-830-11	CARBON	910	5%	1/4W
R64	1-249-429-11	CARBON	10K	5%	1/4W	R132	1-247-830-11	CARBON	910	5%	1/4W
R65	1-249-405-11	CARBON	100	5%	1/4W	R134	1-215-453-00	METAL	22K	1%	1/6W
R66	1-249-417-11	CARBON	1K	5%	1/4W	R135	1-215-453-00	METAL	22K	1%	1/6W
R67	1-249-433-11	CARBON	22K	5%	1/4W	R136	1-215-453-00	METAL	22K	1%	1/6W
R68	1-249-425-11	CARBON	4.7K	5%	1/4W	R137	1-215-453-00	METAL	22K	1%	1/6W
R69	1-249-435-11	CARBON	33K	5%	1/4W	R138	1-215-453-00	METAL	22K	1%	1/6W
R70	1-249-421-11	CARBON	2.2K	5%	1/4W	R139	1-215-453-00	METAL	22K	1%	1/6W
R71	1-249-417-11	CARBON	1K	5%	1/4W	R140	1-215-453-00	METAL	22K	1%	1/6W
R72	1-249-433-11	CARBON	22K	5%	1/4W	R141	1-215-453-00	METAL	22K	1%	1/6W
R73	1-249-425-11	CARBON	4.7K	5%	1/4W	R142	1-215-453-00	METAL	22K	1%	1/6W
R74	1-247-903-00	CARBON	1M	5%	1/4W	R143	1-215-453-00	METAL	22K	1%	1/6W
R75	1-249-429-11	CARBON	10K	5%	1/4W	R144	1-215-453-00	METAL	22K	1%	1/6W
R76	1-249-429-11	CARBON	10K	5%	1/4W	R145	1-215-453-00	METAL	22K	1%	1/6W
R77	1-249-429-11	CARBON	10K	5%	1/4W	R146	1-215-453-00	METAL	22K	1%	1/6W
R78	1-215-469-00	METAL	100K	1%	1/6W	R147	1-215-453-00	METAL	22K	1%	1/6W
R79	1-249-405-11	CARBON	100	5%	1/4W	R148	1-215-453-00	METAL	22K	1%	1/6W
R80	1-249-417-11	CARBON	1K	5%	1/4W	R149	1-215-461-00	METAL	47K	1%	1/6W
R81	1-249-433-11	CARBON	22K	5%	1/4W	R150	1-215-461-00	METAL	47K	1%	1/6W
R82	1-249-425-11	CARBON	4.7K	5%	1/4W	R151	1-215-467-00	METAL	82K	1%	1/6W
R83	1-249-435-11	CARBON	33K	5%	1/4W	R152	1-215-461-00	METAL	47K	1%	1/6W
R84	1-249-421-11	CARBON	2.2K	5%	1/4W	R153	1-215-461-00	METAL	47K	1%	1/6W
R85	1-249-417-11	CARBON	1K	5%	1/4W	R154	1-215-445-00	METAL	10K	1%	1/6W
R86	1-249-433-11	CARBON	22K	5%	1/4W	R155	1-215-457-00	METAL	33K	1%	1/6W
R87	1-249-425-11	CARBON	4.7K	5%	1/4W	R156	1-215-469-00	METAL	100K	1%	1/6W
R88	1-247-895-00	CARBON	470K	5%	1/4W	R157	1-215-457-00	METAL	33K	1%	1/6W
R89	1-247-895-00	CARBON	470K	5%	1/4W	R158	1-215-445-00	METAL	10K	1%	1/6W
R90	1-249-429-11	CARBON	10K	5%	1/4W	R159	1-215-461-00	METAL	47K	1%	1/6W
R91	1-249-429-11	CARBON	10K	5%	1/4W	R160	1-215-461-00	METAL	47K	1%	1/6W
R92	1-215-469-00	METAL	100K	1%	1/6W	R161	1-215-467-00	METAL	82K	1%	1/6W
R93	1-249-405-11	CARBON	100	5%	1/4W	R162	1-215-461-00	METAL	47K	1%	1/6W
R94	1-249-417-11	CARBON	1K	5%	1/4W	R163	1-215-461-00	METAL	47K	1%	1/6W
R95	1-249-433-11	CARBON	22K	5%	1/4W	R164	1-215-461-00	METAL	47K	1%	1/6W
R96	1-249-425-11	CARBON	4.7K	5%	1/4W	R165	1-215-449-00	METAL	15K	1%	1/6W
R97	1-249-435-11	CARBON	33K	5%	1/4W	R166	1-249-433-11	CARBON	22K	5%	1/4W
R98	1-249-421-11	CARBON	2.2K	5%	1/4W	R167	1-249-437-11	CARBON	47K	5%	1/4W
R99	1-249-417-11	CARBON	1K	5%	1/4W	R168	1-215-445-00	METAL	10K	1%	1/6W
R100	1-249-433-11	CARBON	22K	5%	1/4W	R169	1-247-903-00	CARBON	1M	5%	1/4W
R101	1-249-425-11	CARBON	4.7K	5%	1/4W	R170	1-247-903-00	CARBON	1M	5%	1/4W
R102	1-247-895-00	CARBON	470K	5%	1/4W	R171	1-249-441-11	CARBON	100K	5%	1/4W
R103	1-247-895-00	CARBON	470K	5%	1/4W	R172	1-249-429-11	CARBON	10K	5%	1/4W
R104	1-249-429-11	CARBON	10K	5%	1/4W	R174	1-249-421-11	CARBON	2.2K	5%	1/4W
R105	1-249-429-11	CARBON	10K	5%	1/4W	R175	1-249-421-11	CARBON	2.2K	5%	1/4W
R106	1-215-397-00	METAL	100	1%	1/6W	R176	1-249-425-11	CARBON	4.7K	5%	1/4W
R107	1-249-393-11	CARBON	10	5%	1/4W	R177	1-249-421-11	CARBON	2.2K	5%	1/4W
R108	1-249-393-11	CARBON	10	5%	1/4W	R178	1-249-437-11	CARBON	47K	5%	1/4W
R109	1-249-429-11	CARBON	10K	5%	1/4W	R179	1-249-438-11	CARBON	56K	5%	1/4W
R110	1-215-437-00	METAL	4.7K	1%	1/6W	R180	1-249-440-11	CARBON	82K	5%	1/4W

Ref.No	Part No.	Description	Remark		
R181	1-249-417-11	CARBON	1K	5%	1/4W
R182	1-215-453-00	METAL	22K	1%	1/6W
R183	1-215-469-00	METAL	100K	1%	1/6W
R184	1-215-469-00	METAL	100K	1%	1/6W
R185	1-249-417-11	CARBON	1K	5%	1/4W
R187	1-249-435-11	CARBON	33K	5%	1/4W
R188	1-249-429-11	CARBON	10K	5%	1/4W
R189	1-249-435-11	CARBON	33K	5%	1/4W
R190	1-249-417-11	CARBON	1K	5%	1/4W
R191	1-249-423-11	CARBON	3.3K	5%	1/4W
R192	1-215-453-00	METAL	22K	1%	1/6W
R193	1-249-417-11	CARBON	1K	5%	1/4W
R194	1-249-417-11	CARBON	1K	5%	1/4W

VARIABLE RESISTOR

RV1	1-237-518-21	RES, ADJ, CERMET 10K
RV2	1-237-518-21	RES, ADJ, CERMET 10K
RV3	1-237-518-21	RES, ADJ, CERMET 10K
RV4	1-237-518-21	RES, ADJ, CERMET 10K
RV5	1-237-518-21	RES, ADJ, CERMET 10K
RV6	1-237-518-21	RES, ADJ, CERMET 10K
RV7	1-237-518-21	RES, ADJ, CERMET 10K
RV8	1-237-518-21	RES, ADJ, CERMET 10K
RV9	1-237-518-21	RES, ADJ, CERMET 10K
RV10	1-237-518-21	RES, ADJ, CERMET 10K
RV11	1-237-518-21	RES, ADJ, CERMET 10K
RV12	1-237-518-21	RES, ADJ, CERMET 10K
RV13	1-237-518-21	RES, ADJ, CERMET 10K
RV14	1-237-518-21	RES, ADJ, CERMET 10K
RV15	1-237-518-21	RES, ADJ, CERMET 10K
RV16	1-237-518-21	RES, ADJ, CERMET 10K
RV17	1-237-518-21	RES, ADJ, CERMET 10K
RV18	1-237-518-21	RES, ADJ, CERMET 10K
RV19	1-237-518-21	RES, ADJ, CERMET 10K
RV20	1-237-518-21	RES, ADJ, CERMET 10K
RV21	1-237-518-21	RES, ADJ, CERMET 10K
RV22	1-237-518-21	RES, ADJ, CERMET 10K
RV23	1-237-518-21	RES, ADJ, CERMET 10K
RV24	1-237-518-21	RES, ADJ, CERMET 10K
RV25	1-237-518-21	RES, ADJ, CERMET 10K
RV26	1-237-518-21	RES, ADJ, CERMET 10K
RV27	1-237-518-21	RES, ADJ, CERMET 10K
RV28	1-237-518-21	RES, ADJ, CERMET 10K
RV29	1-237-518-21	RES, ADJ, CERMET 10K
RV30	1-237-518-21	RES, ADJ, CERMET 10K
RV31	1-237-521-21	RES, ADJ, CERMET 100K
RV32	1-237-518-21	RES, ADJ, CERMET 10K
RV33	1-237-518-21	RES, ADJ, CERMET 10K

*A-1345-596-A EA BOARD, COMPLETE

*4-347-706-00 HEAT SINK (TR)
*4-373-965-01 INSULATOR (SMALL)
7-682-548-04 SCREW P 3X8
7-685-646-79 SCREW BVTP 3X8 TYPE2 IT-3

CAPACITOR

C1	1-101-810-00	CERAMIC	100PF	5%	500V
C2	1-123-343-00	ELECT	33MF	20%	25V
C3	1-123-343-00	ELECT	33MF	20%	25V
C4	1-124-046-00	ELECT	10MF		160V
C5	1-124-046-00	ELECT	10MF		160V
C6	1-101-361-00	CERAMIC	150PF	5%	50V

Ref.No	Part No.	Description	Remark		
C7	1-124-046-00	ELECT	10MF		160V
C8	1-136-337-11	FILM	3.3MF	10%	100V
C12	1-102-121-00	CERAMIC	0.0022MF	10%	50V
C13	1-136-165-00	FILM	0.1MF	5%	50V
C14	1-130-728-00	FILM	0.0022MF	5%	50V
C15	1-102-973-00	CERAMIC	100PF	5%	50V
C16	1-123-356-00	ELECT	10MF	20%	25V
C17	1-123-330-00	ELECT	22MF	20%	16V
C18	1-102-973-00	CERAMIC	100PF	5%	50V
C19	1-123-369-00	ELECT	4.7MF	20%	25V
C20	1-136-161-00	FILM	0.047MF	5%	50V
C21	1-101-810-00	CERAMIC	100PF	5%	500V
C22	1-108-700-11	MYLAR	0.047MF	10%	200V
C23	1-123-024-21	ELECT	33MF		160V
C24	1-124-046-00	ELECT	10MF		160V

C25	1-136-113-00	FILM	2MF	5%	200V
C26	1-136-161-00	FILM	0.047MF	5%	50V
C27	1-108-700-11	MYLAR	0.047MF	10%	200V
C28	1-124-666-11	ELECT	4.7MF	20%	200V
C29	1-101-810-00	CERAMIC	100PF	5%	500V
C30	1-162-135-11	CERAMIC	560PF	10%	2KV
C31	1-136-069-00	FILM	0.0044MF	3%	2KV
C32	1-136-069-00	FILM	0.0044MF	3%	2KV
C33	1-124-512-11	ELECT	33MF	20%	50V
C34	1-124-512-11	ELECT	33MF	20%	50V
C35	1-126-163-11	ELECT	4.7MF	20%	50V
C36	1-126-163-11	ELECT	4.7MF	20%	50V
C37	1-161-051-00	CERAMIC	0.01MF	10%	50V
C39	1-162-318-11	CERAMIC	0.001MF	10%	500V
C40	1-123-356-00	ELECT	10MF	20%	16V
C41	1-102-244-00	CERAMIC	220PF	10%	500V
C42	1-102-973-00	CERAMIC	100PF	5%	50V

DIODE

D1	8-719-110-31	DIODE RD12ES-B2
D2	8-719-911-19	DIODE ISS119
D3	8-719-911-19	DIODE ISS119
D4	8-719-911-19	DIODE ISS119
D7	8-719-110-03	DIODE RD7.5ES-B2
D8	8-719-300-76	DIODE RH-1A
D9	8-719-928-08	DIODE ERD28-08S
D10	8-719-300-76	DIODE RH-1A
D11	8-719-300-76	DIODE RH-1A
D12	8-719-300-76	DIODE RH-1A
D13	8-719-109-75	DIODE RD4.3ES-B2
D14	8-719-109-75	DIODE RD4.3ES-B2
D15	8-719-911-19	DIODE ISS119
D16	8-719-911-19	DIODE ISS119TD

CONNECTOR

EA1	*1-568-536-11	PLUG (MINIATURE DY) 6P
-----	---------------	------------------------

IC

IC1	8-759-100-75	IC UPC1394C
IC2	8-759-945-58	IC RC4558P

COIL

L1	1-459-433-00	COIL (WITH CORE)
L2	1-459-433-00	COIL (WITH CORE)
L3	1-459-433-00	COIL (WITH CORE)
L4	1-459-111-00	COIL, DRAM CORE (CDI)
L5	1-459-111-00	COIL, DRAM CORE (CDI)

TRANSISTOR

Q1	8-729-119-78	TRANSISTOR 2SC2785-HFE
----	--------------	------------------------

Ref.No	Part No.	Description	Remark		
Q2	8-729-697-92	TRANSISTOR 2SA979-G			
Q3	8-729-140-96	TRANSISTOR 2SD774-34			
Q4	8-729-303-61	TRANSISTOR 2SC3851-G			
Q5	8-729-304-07	TRANSISTOR 2SA1488-Y			
Q10	8-729-119-80	TRANSISTOR 2SC2688-LK			
Q11	8-729-175-22	TRANSISTOR 2SC2752-L			
Q12	8-729-200-17	TRANSISTOR 2SA1091-O			
Q13	8-729-119-80	TRANSISTOR 2SC2688-LK			
Q14	8-729-202-53	TRANSISTOR 2SD1556-LB			
Q15	8-729-313-42	TRANSISTOR 2SD1134-C			
Q16	8-729-385-82	TRANSISTOR 2SB858-C			
<u>RESISTOR</u>					
R1	1-249-418-11	CARBON	1.2K	5%	1/4W
R2	1-249-425-11	CARBON	4.7K	5%	1/4W
R3	1-249-429-11	CARBON	10K	5%	1/4W
R4	1-249-429-11	CARBON	10K	5%	1/4W
R5	1-249-429-11	CARBON	10K	5%	1/4W
R6	1-249-429-11	CARBON	10K	5%	1/4W
R7	1-249-421-11	CARBON	2.2K	5%	1/4W
R8	1-249-441-11	CARBON	100K	5%	1/4W
R9	1-249-429-11	CARBON	10K	5%	1/4W
R10	1-249-418-11	CARBON	1.2K	5%	1/4W
R11	1-249-448-11	CARBON	1.2	5%	1/4W F
R12	1-249-448-11	CARBON	1.2	5%	1/4W F
R13	1-249-417-11	CARBON	1K	5%	1/4W
R14	1-215-887-00	METAL OXIDE	150	5%	2W F
R15	1-249-429-11	CARBON	10K	5%	1/4W
R22	1-249-417-11	CARBON	1K	5%	1/4W
R23	1-215-445-00	METAL	10K	1%	1/6W
R24	1-215-445-00	METAL	10K	1%	1/6W
R25	1-215-431-00	METAL	2.7K	1%	1/6W
R26	1-215-431-00	METAL	2.7K	1%	1/6W
R27	1-249-435-11	CARBON	33K	5%	1/4W
R28	1-215-461-00	METAL	47K	1%	1/6W
R29	1-249-429-11	CARBON	10K	5%	1/4W
R30	1-249-429-11	CARBON	10K	5%	1/4W
R31	1-247-868-11	CARBON	36K	5%	1/4W
R32	1-249-429-11	CARBON	10K	5%	1/4W
R33	1-249-427-11	CARBON	6.8K	5%	1/4W
R34	1-215-433-00	METAL	3.3K	1%	1/6W
R35	1-215-435-00	METAL	3.9K	1%	1/6W
R36	1-249-429-11	CARBON	10K	5%	1/4W
R37	1-249-441-11	CARBON	100K	5%	1/4W
R38	1-249-429-11	CARBON	10K	5%	1/4W
R39	1-215-469-00	METAL	100K	1%	1/6W
R40	1-249-429-11	CARBON	10K	5%	1/4W
R41	1-249-429-11	CARBON	10K	5%	1/4W
R42	1-215-876-00	METAL OXIDE	15K	5%	1W F
R43	1-215-859-00	METAL OXIDE	22	5%	1W F
R44	1-216-349-00	METAL OXIDE	1	5%	1W F
R45	1-249-417-11	CARBON	1K	5%	1/4W
R46	1-249-417-11	CARBON	1K	5%	1/4W
R47	1-216-463-00	METAL OXIDE	12K	5%	2W F
R48	1-216-346-00	METAL OXIDE	0.56	5%	1W F
R49	1-249-382-11	CARBON	1.2	5%	1/4W F
R50	1-247-826-00	CARBON	620	5%	1/4W
R51	1-247-826-00	CARBON	620	5%	1/4W
R52	1-215-445-00	METAL	10K	1%	1/6W
R53	1-215-445-00	METAL	10K	1%	1/6W
R54	1-215-445-00	METAL	10K	1%	1/6W
R55	1-249-394-11	CARBON	12	5%	1/4W F
R56	1-215-445-00	METAL	10K	1%	1/6W
R57	1-215-445-00	METAL	10K	1%	1/6W
R58	1-249-405-11	CARBON	100	5%	1/4W

Ref.No	Part No.	Description	Remark		
R59	1-249-419-11	CARBON	1.5K	5%	1/4W
R60	1-249-419-11	CARBON	1.5K	5%	1/4W
R61	1-215-882-00	METAL OXIDE	22	5%	2W F
R62	1-215-882-00	METAL OXIDE	22	5%	2W F
R63	1-216-361-00	METAL OXIDE	0.22	5%	2W F

TRANSFORMER

T1	1-460-067-11	HLT			
T2	1-407-850-00	DLT			
T3	1-437-078-00	TRANSFORMER, HORIZONTAL DRIVE			
T4	1-437-079-00	TRANSFORMER, HORIZONTAL DRIVE			
T5	1-439-383-11	HOT			

*A-1345-597-A EB BOARD, COMPLETE

*4-373-965-01 INSULATOR (SMALL)

*4-373-966-01 INSULATOR (LARGE)

7-682-548-04 SCREW P 3X8

CAPACITOR

C1	1-124-666-11	ELECT	4.7MF	20%	200V
C2	1-124-357-11	ELECT	33MF	20%	35V
C3	1-123-380-00	ELECT	1MF	20%	50V
C4	1-124-357-11	ELECT	33MF	20%	35V
C6	1-130-789-00	FILM	1MF	5%	100V
C7	1-108-696-11	MYLAR	0.022MF	10%	200V
C8	1-124-666-11	ELECT	4.7MF	20%	200V
C9	1-130-479-00	MYLAR	0.0047MF	5%	50V
C10	1-124-122-11	ELECT	100MF	20%	25V
C11	1-102-973-00	CERAMIC	100PF	5%	50V
C12	1-124-122-11	ELECT	100MF	20%	25V
C13	1-136-161-00	FILM	0.047MF	5%	50V
C14	1-123-356-00	ELECT	10MF	20%	50V
C15	1-136-167-00	FILM	0.15MF	5%	50V
C16	1-124-046-00	ELECT	10MF		160V
C17	1-124-046-00	ELECT	10MF	20%	160V
C18	1-124-122-11	ELECT	100MF	20%	25V
C19	1-124-122-11	ELECT	100MF	20%	25V
C20	1-162-129-00	CERAMIC	150PF	10%	2KV
C21	1-136-173-00	FILM	0.47MF	5%	50V
C22	1-102-959-00	CERAMIC	22PF	5%	50V
C23	1-101-880-00	CERAMIC	47PF	5%	50V

DIODE

D1	8-719-911-19	DIODE 1SS119			
D2	8-719-911-19	DIODE 1SS119			
D3	8-719-911-19	DIODE 1SS119			
D4	8-719-911-55	DIODE U05G			
D5	8-719-911-55	DIODE U05G			
D6	8-719-911-19	DIODE 1SS119			
D7	8-719-911-19	DIODE 1SS119			
D8	8-719-911-19	DIODE 1SS119			
D9	8-719-911-19	DIODE 1SS119			
D10	8-719-911-19	DIODE 1SS119			

COIL

L1	1-459-075-00	COIL,DYNAMIC CONVERSION CHOKE			
----	--------------	-------------------------------	--	--	--

TRANSISTOR

Q1	8-729-697-92	TRANSISTOR 2SA979-G			
Q2	8-729-140-96	TRANSISTOR 2SD774-34			
Q3	8-729-309-08	TRANSISTOR 2SC1890A-E			
Q4	8-729-309-36	TRANSISTOR 2SA893A-EV			
Q5	8-729-300-70	TRANSISTOR 2SD1137			

The components identified by shading and mark Δ are critical for safety.
 Replace only with part number specified.



Ref.No	Part No.	Description	Remark
Q6	8-729-300-80	TRANSISTOR 2SB860	
Q7	8-729-386-12	TRANSISTOR 2SB861-C	
Q8	8-729-255-12	TRANSISTOR 2SC2551-O	
Q9	8-729-697-92	TRANSISTOR 2SA979-G	
Q10	8-729-140-96	TRANSISTOR 2SD774-34	
Q11	8-729-374-02	TRANSISTOR 2SB740-3	
Q12	8-729-306-92	TRANSISTOR 2SD669A-C	
Q13	8-729-306-92	TRANSISTOR 2SD669A-C	
Q14	8-729-255-12	TRANSISTOR 2SC2551-O	
Q15	8-729-255-12	TRANSISTOR 2SC2551-O	
Q16	8-729-255-12	TRANSISTOR 2SC2551-O	
Q17	8-729-200-17	TRANSISTOR 2SA1091-O	
Q18	8-729-119-80	TRANSISTOR 2SC2688-LK	
Q19	8-729-119-80	TRANSISTOR 2SC2688-LK	
RESISTOR			
R1	1-249-429-11	CARBON 10K 5% 1/4W	
R2	1-249-433-11	CARBON 22K 5% 1/4W	
R3	1-249-425-11	CARBON 4.7K 5% 1/4W	
R4	1-249-430-11	CARBON 12K 5% 1/4W	
R5	1-249-426-11	CARBON 5.6K 5% 1/4W	
R6	1-249-429-11	CARBON 10K 5% 1/4W	
R7	1-216-465-11	METAL OXIDE 27K 5% 2W	F
R8	1-247-802-11	CARBON 62 5% 1/4W	
R9	1-249-414-11	CARBON 560 5% 1/4W	
R10	1-249-448-11	CARBON 1.2 5% 1/4W	F
R11	1-249-448-11	CARBON 1.2 5% 1/4W	F
R12	1-216-351-00	METAL OXIDE 1.5 5% 1W	F
R13	1-216-431-11	METAL OXIDE 560 5% 1W	F
R14	1-215-866-11	METAL OXIDE 330 5% 1W	F
R15	1-249-425-11	CARBON 4.7K 5% 1/4W	
R16	1-249-423-11	CARBON 3.3K 5% 1/4W	F
R17	1-247-700-11	CARBON 100 5% 1/4W	F
R18	1-215-873-00	METAL OXIDE 4.7K 5% 1W	F
R19	1-249-429-11	CARBON 10K 5% 1/4W	
R20	1-249-429-11	CARBON 10K 5% 1/4W	
R21	1-249-425-11	CARBON 4.7K 5% 1/4W	
R22	1-249-425-11	CARBON 4.7K 5% 1/4W	
R23	1-249-425-11	CARBON 4.7K 5% 1/4W	
R24	1-249-417-11	CARBON 1K 5% 1/4W	
R25	1-249-417-11	CARBON 1K 5% 1/4W	
R26	1-249-421-11	CARBON 2.2K 5% 1/4W	
R27	1-249-421-11	CARBON 2.2K 5% 1/4W	
R28	1-249-405-11	CARBON 100 5% 1/4W	
R29	1-249-452-11	CARBON 2.7 5% 1/4W	F
R30	1-249-452-11	CARBON 2.7 5% 1/4W	F
R31	1-249-407-11	CARBON 150 5% 1/4W	F
R32	1-216-351-00	METAL OXIDE 1.5 5% 1W	F
R33	1-215-421-00	METAL 1K 1% 1/6W	
R34	1-215-445-00	METAL 10K 1% 1/6W	
R35	1-249-423-11	CARBON 3.3K 5% 1/4W	
R36	1-216-465-11	METAL OXIDE 27K 5% 2W	F
R37	1-249-401-11	CARBON 47 5% 1/4W	
R38	1-249-425-11	CARBON 4.7K 5% 1/4W	
R39	1-215-445-00	METAL 10K 1% 1/6W	
R40	1-215-453-00	METAL 22K 1% 1/6W	
R41	1-215-421-00	METAL 1K 1% 1/6W	
R42	1-247-688-11	CARBON 10 5% 1/4W	F
R43	1-247-688-11	CARBON 10 5% 1/4W	F
R44	1-215-865-11	METAL OXIDE 220 5% 1W	F
R45	1-247-688-11	CARBON 10 5% 1/4W	F
TRANSFORMER			
T1	1-421-504-00	TRANSFORMER, FERRITE (VPT)	
T2	1-407-849-00	TRANSFORMER, D.F	

Ref.No	Part No.	Description	Remark
*A-1316-056-A	GA BOARD, COMPLETE	(BVM-1410P ONLY)	

*A-1316-048-A	GA BOARD, COMPLETE	(BVM-1410PM ONLY)	

Δ 1-532-203-11	FUSE, TIME-LAG 2A/250V	(BVM-1410P ONLY)	
1-533-167-21	HOLDER, FUSE		
1-533-168-21	HOLDER, FUSE		
1-535-316-11	TERMINAL, GROUND (M4)		
Δ 1-570-173-22	SWITCH, VOLTAGE CHANGE		
Δ *1-580-375-11	INLET 3P		
*2-990-241-01	HOLDER (A), PLUG		
*3-337-402-01	BAND, BINDING		
*4-347-706-00	HEAT SINK (TR)		
*4-371-879-02	COVER, AC SELECT		
4-379-403-01	SPACER (G1), POLISHING		
*4-379-408-01	INSULATOR (G3)		
*4-379-409-01	NUT, PLATE		
4-379-410-01	SPACER (G2), POLISHING		
*4-379-430-03	PANEL, POWER		
*4-386-847-01	HEAT SINK (S.R.T)		
*4-386-848-01	BAND (S.R.T)		
*4-393-031-01	COVER, FUSE HOLDER		
4-601-466-11	COVER, 3P INLET		
7-682-247-04	SCREW K 3X6		
7-682-547-04	SCREW BVTT 3X6 (S)		
7-682-547-09	SCREW B 3X6		
7-682-550-04	SCREW P 3X12		
7-682-552-04	SCREW P 3X16		
7-682-554-04	SCREW P 3X25		
7-682-560-04	SCREW P 4X6		
7-682-948-01	SCREW PSW 3X8		
7-685-646-79	SCREW BVTP 3X8 TYPE2 IT-3		
CAPACITOR			
C1	1-124-024-00	ELECT 4.7MF 20% 350V	
C2	1-124-024-00	ELECT 4.7MF 20% 350V	
C3	1-162-117-00	CERAMIC 100PF 10% 500V	
C4	1-162-117-00	CERAMIC 100PF 10% 500V	
C5	1-162-117-00	CERAMIC 100PF 10% 500V	
C6	1-162-117-00	CERAMIC 100PF 10% 500V	
C7	1-126-104-11	ELECT 470MF 20% 25V	
C8	1-126-105-11	ELECT 1000MF 20% 25V	
C9	1-126-104-11	ELECT 470MF 20% 25V	
C10	1-126-105-11	ELECT 1000MF 20% 25V	
C11	1-126-104-11	ELECT 470MF 20% 25V	
C12	1-124-602-00	ELECT 2200MF 20% 25V	
C13	1-126-104-11	ELECT 470MF 20% 25V	
C14	1-124-602-00	ELECT 2200MF 20% 25V	
C15	1-124-360-00	ELECT 1000MF 20% 16V	
C16	1-126-103-11	ELECT 470MF 20% 16V	
C17	1-106-375-12	MYLAR 0.022MF 10% 100V	
C18	1-108-638-11	MYLAR 0.1MF 10% 100V	
C19	1-102-030-00	CERAMIC 330PF 10% 500V	
C20	1-162-117-00	CERAMIC 100PF 10% 500V	
C21	1-102-038-00	CERAMIC 0.001MF 500V	
C22	1-162-117-00	CERAMIC 100PF 10% 500V	
C23	1-106-375-12	MYLAR 0.022MF 10% 100V	
C24	1-108-638-11	MYLAR 0.1MF 10% 100V	
C25	1-123-380-00	ELECT 1MF 20% 50V	
C26	1-101-361-00	CERAMIC 150PF 5% 50V	
C27	1-101-361-00	CERAMIC 150PF 5% 50V	
C28	1-123-356-00	ELECT 10MF 20% 16V	
C29	1-123-332-00	ELECT 47MF 20% 25V	
C30	1-162-117-00	CERAMIC 100PF 10% 500V	

The components identified by shading and mark Δ are critical for safety.
Replace only with part number specified.

The components identified by \boxtimes in this manual have been carefully factory-selected for each set in order to satisfy regulations regarding X-ray radiation. Should replacement be required, replace only with the value originally used.

GA

Ref.No	Part No.	Description	Remark
L9	1-459-645-11	COIL, CHOKE 20MMH	
L10	1-421-329-00	COIL, CHOKE	
L11	1-421-329-00	COIL, CHOKE	
L12	1-421-329-00	COIL, CHOKE	
L13	1-421-329-00	COIL, CHOKE	
L14	1-421-329-00	COIL, CHOKE	
L15	1-421-329-00	COIL, CHOKE	
L16	1-421-329-00	COIL, CHOKE	
L17	Δ 1-421-590-11	TRANSFORMER, LINE FILTER	
L18	Δ 1-421-590-11	TRANSFORMER, LINE FILTER	

TRANSISTOR

Q1	8-729-301-76	TRANSISTOR STR8124-R	
Q2	8-729-301-76	TRANSISTOR STR8124-R	
Q3	8-729-140-96	TRANSISTOR 2SD774-34	
Q4	8-729-140-96	TRANSISTOR 2SD774-34	
Q5	8-729-140-96	TRANSISTOR 2SD774-34	
Q6	8-729-140-96	TRANSISTOR 2SD774-34	
Q7	8-729-140-97	TRANSISTOR 2SB734-34	
Q8	8-729-119-78	TRANSISTOR 2SC2785-HFE	
Q9	8-729-119-78	TRANSISTOR 2SC2785-HFE	
Q10	8-729-313-42	TRANSISTOR 2SD1134-C	
Q11	8-729-119-76	TRANSISTOR 2SA1175-HFE	
Q12	8-729-140-96	TRANSISTOR 2SD774-34	
Q13	8-729-119-78	TRANSISTOR 2SC2785-HFE	
Q14	8-729-119-78	TRANSISTOR 2SC2785-HFE	

RESISTOR

R1	1-215-857-11	METAL OXIDE	10	5%	1W	F
R2	1-215-857-11	METAL OXIDE	10	5%	1W	F
R3	1-247-715-11	CARBON	1.5K	5%	1/4W	
R4	1-215-857-11	METAL OXIDE	10	5%	1W	F
R5	1-215-857-11	METAL OXIDE	10	5%	1W	F
R6	1-249-447-11	CARBON	1	5%	1/4W	F
R7	1-247-692-11	CARBON	22	5%	1/4W	
R8	1-249-418-11	CARBON	1.2K	5%	1/4W	
R9	1-249-382-11	CARBON	1.2	5%	1/4W	F
R10	1-249-447-11	CARBON	1	5%	1/4W	F
R11	1-247-692-11	CARBON	22	5%	1/4W	
R12	1-249-418-11	CARBON	1.2K	5%	1/4W	
R13	1-215-866-11	METAL OXIDE	330	5%	1W	F
R14	1-247-700-11	CARBON	100	5%	1/4W	
R15	1-247-709-11	CARBON	510	5%	1/4W	
R16	1-247-709-11	CARBON	510	5%	1/4W	
R17	1-247-700-11	CARBON	100	5%	1/4W	
R18	1-249-425-11	CARBON	4.7K	5%	1/4W	
R19	1-249-419-11	CARBON	1.5K	5%	1/4W	
R20	1-247-838-00	CARBON	2K	5%	1/4W	
R21	1-249-417-11	CARBON	1K	5%	1/4W	
R22	1-249-409-11	CARBON	220	5%	1/4W	
R23	1-249-417-11	CARBON	1K	5%	1/4W	
R24	1-249-421-11	CARBON	2.2K	5%	1/4W	
R25	1-249-409-11	CARBON	220	5%	1/4W	
R26	1-247-700-11	CARBON	100	5%	1/4W	
R27	1-247-713-11	CARBON	1K	5%	1/4W	
R28	1-247-713-11	CARBON	1K	5%	1/4W	
R29	1-247-700-11	CARBON	100	5%	1/4W	
R30	1-215-886-11	METAL OXIDE	100	5%	2W	F
R31	1-215-886-11	METAL OXIDE	100	5%	2W	F
R32	1-215-886-11	METAL OXIDE	100	5%	2W	F
R33	1-247-697-11	CARBON	56	5%	1/4W	F
R34	1-247-697-11	CARBON	56	5%	1/4W	F
R35	1-215-863-11	METAL OXIDE	100	5%	1W	F
R36	1-249-425-11	CARBON	4.7K	5%	1/4W	
R37	1-249-420-11	CARBON	1.8K	5%	1/4W	
R38	1-249-429-11	CARBON	10K	5%	1/4W	

Ref.No	Part No.	Description	Remark
R39	1-249-413-11	CARBON	470 5% 1/4W
R40	1-215-453-00	METAL	22K 1% 1/6W
R41	1-249-425-11	CARBON	4.7K 5% 1/4W
R42	1-215-437-00	METAL	4.7K 1% 1/6W
R43	1-215-435-00	METAL	3.9K 1% 1/6W
R44	1-215-427-00	METAL	1.8K 1% 1/6W
R45	1-247-713-11	CARBON	1K 5% 1/4W
R46	1-249-417-11	CARBON	1K 5% 1/4W
R47	1-216-995-11	METAL	820 1% 10W
R48	1-215-866-11	METAL OXIDE	330 5% 1W F

\boxtimes R52	Δ	METAL OXIDE	5%	2W	F
\boxtimes R53	Δ	METAL	1%	1/6W	
R54	1-215-901-00	METAL OXIDE	33K	5%	2W F
R55	1-215-426-00	METAL	1.6K	1%	1/6W
R60	1-249-420-11	CARBON	1.8K	5%	1/4W
R61	1-249-420-11	CARBON	1.8K	5%	1/4W
R62	1-249-429-11	CARBON	10K	5%	1/4W
R64	1-249-426-11	CARBON	5.6K	5%	1/4W
R65	1-215-437-00	METAL	4.7K	1%	1/6W
R66	1-215-453-00	METAL	22K	1%	1/6W
\boxtimes R67	Δ	METAL	1%	1/2W	
\boxtimes R68	Δ	METAL	1%	1/6W	
R74	1-215-889-00	METAL OXIDE	330	5%	2W F
R77	1-215-433-00	METAL	3.3K	1%	1/6W
R78	1-215-433-00	METAL	3.3K	1%	1/6W

R80	Δ 1-202-643-35	SOLID	820K	10%	1/2W	
R81	1-215-461-00	METAL	47K	1%	1/6W	
R82	1-215-461-00	METAL	47K	1%	1/6W	
R83	1-215-461-00	METAL	47K	1%	1/6W	
R84	1-215-459-00	METAL	39K	1%	1/6W	
R85	1-215-449-00	METAL	15K	1%	1/6W	
R86	1-215-437-00	METAL	4.7K	1%	1/6W	
R87	1-249-405-11	CARBON	100	5%	1/4W	
R88	1-249-433-11	CARBON	22K	5%	1/4W	
R89	1-249-429-11	CARBON	10K	5%	1/4W	
R90	1-249-429-11	CARBON	10K	5%	1/4W	
R91	1-249-429-11	CARBON	10K	5%	1/4W	
R92	Δ 1-217-295-11	WIREWOUND	5.6	10%	5W F	
R93	1-215-886-11	METAL OXIDE	100	5%	2W F	
R94	1-205-538-00	WIREWOUND	4.7	10%	10W	
R95	1-215-904-11	METAL OXIDE	100K	5%	2W F	
R96	1-215-904-11	METAL OXIDE	100K	5%	2W F	
R97	1-215-904-11	METAL OXIDE	100K	5%	2W F	
R98	1-215-904-11	METAL OXIDE	100K	5%	2W F	

VARIABLE RESISTOR

RV1	1-237-514-21	RES, ADJ, CERMET 500	
RV2	1-237-515-21	RES, ADJ, CERMET 1K	

RELAY

RY1	Δ 1-515-805-11	RELAY, POWER	
-----	-----------------------	--------------	--

TRANSFORMER

T1	Δ 1-448-433-11	TRANSFORMER, CONVERTER (S.R.T)	
T2	Δ 1-447-106-11	TRANSFORMER, DRIVE	
T3	Δ 1-421-624-12	TRANSFORMER, CURRENT	
T4	Δ 1-447-426-12	TRANSFORMER, CONVERTER	
T5	Δ 1-448-432-12	TRANSFORMER, CONVERTER (S.R.T)	
T6	Δ 1-447-106-11	TRANSFORMER, DRIVE	
T7	Δ 1-421-624-12	TRANSFORMER, CURRENT	

THERMISTOR

TH1	Δ 1-800-820-12	THERMISTOR, POWER	
THP1	Δ 1-806-387-12	THERMISTOR (POSITIVE)	
THP2	Δ 1-800-686-33	THERMISTOR (POSITIVE)	



Ref.No Part No. Description Remark

*1-617-884-11 GB BOARD

CAPACITOR

C1 1-123-380-00 ELECT 1MF 20% 50V
C2 1-123-380-00 ELECT 1MF 20% 50V

DIODE

D1 8-719-911-19 DIODE 1SS119
D2 8-719-110-08 DIODE RD8.2ES-B2
D3 8-719-911-19 DIODE 1SS119
D4 8-719-911-19 DIODE 1SS119
D5 8-719-911-19 DIODE 1SS119

D6 8-719-110-08 DIODE RD8.2ES-B2
D7 8-719-812-41 DIODE TLR124
D8 8-719-911-19 DIODE 1SS119
D9 8-719-911-19 DIODE 1SS119
D10 8-719-812-41 DIODE TLR124

D11 8-719-110-08 DIODE RD8.2ES-B2
D12 8-719-911-19 DIODE 1SS119
D13 8-719-911-19 DIODE 1SS119
D14 8-719-911-19 DIODE 1SS119
D15 8-719-911-19 DIODE 1SS119

D16 8-719-911-19 DIODE 1SS119
D17 8-719-110-08 DIODE RD8.2ES-B2
D18 8-719-911-19 DIODE 1SS119
D19 8-719-911-19 DIODE 1SS119

CONNECTOR

GA1 *1-506-603-11 PLUG, L TYPE (2.0MM PITCH) 10P

TRANSISTOR

Q1 8-729-119-76 TRANSISTOR 2SA1175-HFE
Q2 8-729-119-78 TRANSISTOR 2SC2785-HFE
Q3 8-729-119-76 TRANSISTOR 2SA1175-HFE
Q4 8-729-119-78 TRANSISTOR 2SC2785-HFE
Q5 8-729-119-76 TRANSISTOR 2SA1175-HFE

Q6 8-729-119-76 TRANSISTOR 2SA1175-HFE
Q7 8-729-119-76 TRANSISTOR 2SA1175-HFE
Q8 8-729-119-78 TRANSISTOR 2SC2785-HFE
Q9 8-729-119-76 TRANSISTOR 2SA1175-HFE
Q10 8-729-119-78 TRANSISTOR 2SC2785-HFE

RESISTOR

R1 1-249-427-11 CARBON 6.8K 5% 1/4W
R2 1-249-428-11 CARBON 8.2K 5% 1/4W
R3 1-249-429-11 CARBON 10K 5% 1/4W
R4 1-249-427-11 CARBON 6.8K 5% 1/4W
R5 1-249-420-11 CARBON 1.8K 5% 1/4W

R6 1-249-427-11 CARBON 6.8K 5% 1/4W
R7 1-249-420-11 CARBON 1.8K 5% 1/4W
R8 1-249-429-11 CARBON 10K 5% 1/4W
R9 1-249-427-11 CARBON 6.8K 5% 1/4W
R10 1-249-428-11 CARBON 8.2K 5% 1/4W

R11 1-249-424-11 CARBON 3.9K 5% 1/4W
R12 1-249-421-11 CARBON 2.2K 5% 1/4W
R13 1-249-425-11 CARBON 4.7K 5% 1/4W
R14 1-249-421-11 CARBON 2.2K 5% 1/4W
R15 1-249-424-11 CARBON 3.9K 5% 1/4W

R16 1-249-421-11 CARBON 2.2K 5% 1/4W
R17 1-249-425-11 CARBON 4.7K 5% 1/4W
R18 1-249-421-11 CARBON 2.2K 5% 1/4W
R19 1-249-429-11 CARBON 10K 5% 1/4W
R20 1-249-429-11 CARBON 10K 5% 1/4W

Ref.No Part No. Description Remark

R21 1-249-429-11 CARBON 10K 5% 1/4W
R22 1-249-423-11 CARBON 3.3K 5% 1/4W
R23 1-249-423-11 CARBON 3.3K 5% 1/4W
R24 1-249-429-11 CARBON 10K 5% 1/4W
R25 1-249-429-11 CARBON 10K 5% 1/4W

*1-617-885-11 GC BOARD

CAPACITOR

C1 1-123-330-00 ELECT 22MF 20% 25V
C2 1-123-330-00 ELECT 22MF 20% 25V
C3 1-123-330-00 ELECT 22MF 20% 25V
C4 1-123-330-00 ELECT 22MF 20% 25V
C5 1-123-330-00 ELECT 22MF 20% 25V

C6 1-123-330-00 ELECT 22MF 20% 25V
C7 1-123-330-00 ELECT 22MF 20% 25V
C8 1-123-330-00 ELECT 22MF 20% 25V
C9 1-123-330-00 ELECT 22MF 20% 25V
C12 1-101-004-00 CERAMIC 0.01MF 50V

C14 1-101-004-00 CERAMIC 0.01MF 50V
C16 1-101-004-00 CERAMIC 0.01MF 50V
C17 1-101-004-00 CERAMIC 0.01MF 50V
C18 1-101-004-00 CERAMIC 0.01MF 50V

CONNECTOR

GC1 *1-566-044-11 PIN, CONNECTOR 5P
GC2 *1-566-057-11 PIN, CONNECTOR 5P
GC3 *1-566-044-11 PIN, CONNECTOR 5P

IC

IC1 8-759-929-65 IC LM7912CT
IC2 8-759-929-65 IC LM7912CT
IC3 8-759-929-62 IC LM7812CT
IC4 8-759-929-62 IC LM7812CT

*1-617-890-11 HA BOARD

CONNECTOR

HA1 *1-566-055-11 PIN, CONNECTOR 3P
HA2 *1-566-056-11 PIN, CONNECTOR 4P
HA3 *1-566-064-11 PIN, CONNECTOR 12P
HA4 *1-566-054-11 PIN, CONNECTOR 2P

RESISTOR

R1 1-247-814-11 CARBON 200 5% 1/4W
R2 1-215-469-00 METAL 100K 1% 1/6W

VARIABLE RESISTOR

RV1 1-237-519-21 RES, ADJ, CERMET 20K

SWITCH

S1 1-570-565-11 SWITCH, PUSH (10 KEY)
S2 1-570-565-11 SWITCH, PUSH (10 KEY)
S3 1-570-565-11 SWITCH, PUSH (10 KEY)
S4 1-570-565-11 SWITCH, PUSH (10 KEY)
S5 1-570-565-11 SWITCH, PUSH (10 KEY)

S6 1-570-565-11 SWITCH, PUSH (10 KEY)
S7 1-570-565-11 SWITCH, PUSH (10 KEY)
S8 1-570-565-11 SWITCH, PUSH (10 KEY)
S9 1-570-565-11 SWITCH, PUSH (10 KEY)

ELECTRICAL PARTS LIST

HA	HB	HC	HD	HE	HG
-----------	-----------	-----------	-----------	-----------	-----------

Ref.No	Part No.	Description	Remark
S10	1-570-565-11	SWITCH, PUSH (10 KEY)	

	*1-617-886-11	HB BOARD	*****
	1-570-568-11	SWITCH, PUSH (4 KEY)	
	1-570-569-11	SWITCH, PUSH (3 KEY)	
<u>CAPACITOR</u>			
C1	1-124-034-51	ELECT	33MF 20% 16V
C2	1-124-034-51	ELECT	33MF 20% 16V
C3	1-101-004-00	CERAMIC	0.01MF 50V
C4	1-101-004-00	CERAMIC	0.01MF 50V
C5	1-101-004-00	CERAMIC	0.01MF 50V
C6	1-101-004-00	CERAMIC	0.01MF 50V
C7	1-101-004-00	CERAMIC	0.01MF 50V
<u>DIODE</u>			
D1	8-719-938-68	DIODE GL3HY8	
D2	8-719-938-68	DIODE GL3HY8	
D3	8-719-938-68	DIODE GL3HY8	
D4	8-719-938-68	DIODE GL3HY8	
D5	8-719-812-43	DIODE TLG124A	
D6	8-719-812-43	DIODE TLG124A	
D7	8-719-812-43	DIODE TLG124A	
<u>CONNECTOR</u>			
HB1	*1-566-064-11	PIN, CONNECTOR 12P	
HB2	*1-566-062-11	PIN, CONNECTOR 10P	
HB3	*1-566-060-11	PIN, CONNECTOR 8P	
HB4	*1-566-064-11	PIN, CONNECTOR 12P	
HB5	*1-566-058-11	PIN, CONNECTOR 6P	
HB6	*1-566-064-11	PIN, CONNECTOR 12P	
<u>RESISTOR</u>			
R1	1-215-469-00	METAL	100K 1% 1/6W
R2	1-215-469-00	METAL	100K 1% 1/6W
R3	1-215-469-00	METAL	100K 1% 1/6W
R4	1-215-469-00	METAL	100K 1% 1/6W
R5	1-215-469-00	METAL	100K 1% 1/6W
R6	1-215-469-00	METAL	100K 1% 1/6W
R7	1-215-469-00	METAL	100K 1% 1/6W
R8	1-215-469-00	METAL	100K 1% 1/6W
R9	1-215-469-00	METAL	100K 1% 1/6W
R10	1-215-469-00	METAL	100K 1% 1/6W
R11	1-215-469-00	METAL	100K 1% 1/6W
R12	1-249-425-11	CARBON	4.7K 5% 1/4W
R13	1-249-423-11	CARBON	3.3K 5% 1/4W
R15	1-249-423-11	CARBON	3.3K 5% 1/4W
R16	1-249-423-11	CARBON	3.3K 5% 1/4W
R17	1-249-423-11	CARBON	3.3K 5% 1/4W
<u>VARIABLE RESISTOR</u>			
RV1	1-237-519-21	RES, ADJ, CERMET 20K	
RV2	1-237-519-21	RES, ADJ, CERMET 20K	
RV3	1-237-519-21	RES, ADJ, CERMET 20K	
RV4	1-237-519-21	RES, ADJ, CERMET 20K	
RV5	1-237-520-21	RES, ADJ, CERMET 50K	
RV6	1-237-520-21	RES, ADJ, CERMET 50K	
RV7	1-237-520-21	RES, ADJ, CERMET 50K	
RV8	1-237-520-21	RES, ADJ, CERMET 50K	
RV9	1-237-520-21	RES, ADJ, CERMET 50K	
RV10	1-237-520-21	RES, ADJ, CERMET 50K	

Ref.No	Part No.	Description	Remark
RV11	1-237-520-21	RES, ADJ, CERMET 50K	
RV12	1-237-521-21	RES, ADJ, CERMET 100K	
<u>SWITCH</u>			
S8	1-570-509-11	SWITCH, TOGGLE	
S9	1-570-509-11	SWITCH, TOGGLE	
S10	1-570-509-11	SWITCH, TOGGLE	
S11	1-570-510-11	SWITCH, TOGGLE	
S12	1-570-509-11	SWITCH, TOGGLE	
S13	1-570-509-11	SWITCH, TOGGLE	
S14	1-570-512-11	SWITCH, TOGGLE	
S15	1-570-509-11	SWITCH, TOGGLE	

	*1-617-887-11	HC BOARD	*****
<u>SWITCH</u>			
SW1	1-570-567-21	SWITCH, PUSH (2 KEY)	
SW2	1-570-567-21	SWITCH, PUSH (2 KEY)	
SW3	1-570-567-11	SWITCH, PUSH (2 KEY)	
SW4	1-570-567-11	SWITCH, PUSH (2 KEY)	

	*1-617-893-11	HD BOARD	***** (Serial No. Up to 2001,396 BVM-1410P ONLY) (Serial No. Up to 2,000,020 BVM-1410PM ONLY)
<u>RESISTOR</u>			
R1	1-215-465-00	METAL	68K 1% 1/6W
R2	1-215-451-00	METAL	18K 1% 1/6W
R3	1-215-469-00	METAL	100K 1% 1/6W
R4	1-215-469-00	METAL	100K 1% 1/6W
R5	1-215-425-11	CARBON	4.7K 5% 1/4W
<u>VARIABLE RESISTOR</u>			
RV1	1-230-788-71	RES, VAR, CERMET 20K	
RV2	1-230-788-71	RES, VAR, CERMET 20K	
RV3	1-230-788-71	RES, VAR, CERMET 20K	
RV4	1-230-788-71	RES, VAR, CERMET 20K	
<u>SWITCH</u>			
SW1	1-570-566-11	SWITCH, PUSH (4 KEY)	
SW2	1-570-566-11	SWITCH, PUSH (4 KEY)	
SW3	1-570-566-11	SWITCH, PUSH (4 KEY)	
SW4	1-570-566-11	SWITCH, PUSH (4 KEY)	

	*1-618-814-11	HE BOARD	*****

	1-627-681-11	HG BOARD	***** (Serial No. 2,001,397 and Higher BVM-1410P only) (Serial No. 2,000,021 and Higher BVM-1410PM only)
	*4-026-910-00	HOLDER, LED	
	7-682-547-09	SCREW BVTT 3X6 (S)	
<u>DIODE</u>			
D1	8-719-938-68	DIODE GL3HY8	
D2	8-719-812-41	DIODE TLR124	

HG HH PA

The components identified by shading and mark **Δ** are critical for safety.
Replace only with part number specified.

Ref.No Part No. Description Remark

RESISTOR

R1	1-215-465-00	METAL	68K	1%	1/6W
R2	1-215-451-00	METAL	18K	1%	1/6W
R3	1-215-469-00	METAL	100K	1%	1/6W
R4	1-215-469-00	METAL	100K	1%	1/6W
R5	1-249-425-11	CARBON	4.7K	5%	1/4W

SWITCH

SW1	1-570-566-11	SWITCH, PUSH (4 KEY)
SW2	1-570-566-11	SWITCH, PUSH (4 KEY)
SW3	1-570-566-11	SWITCH, PUSH (4 KEY)
SW4	1-570-566-11	SWITCH, PUSH (4 KEY)

*1-627-682-11 HH BOARD

(Serial No. 2,001,397 and Higher BVM-1410P only)
(Serial No. 2,000,021 and Higher BVM-1410PM only)

CONNECTOR

HH1	1-566-614-11	PLUG (L TYPE) 3 KEY
HH2	1-566-614-11	PLUG (L TYPE) 3 KEY
HH3	1-566-614-11	PLUG (L TYPE) 3 KEY
HH4	1-566-614-11	PLUG (L TYPE) 3 KEY

VARIABLE RESISTOR

RV1	1-238-332-11	RES, VAR, CARBON 20K
RV2	1-238-332-11	RES, VAR, CARBON 20K
RV3	1-238-332-11	RES, VAR, CARBON 20K
RV4	1-238-332-11	RES, VAR, CARBON 20K

*A-1345-598-A PA BOARD, COMPLETE

1-506-108-41 PIN, CONNECTOR (TERMINAL PIN)
7-682-548-04 SCREW P 3X8

CAPACITOR

C101	1-124-046-00	ELECT	10MF	20%	160V
C102	1-123-332-00	ELECT	47MF	20%	25V
C103	1-123-024-21	ELECT	33MF		160V
C104	1-136-171-00	FILM	0.33MF	5%	50V
C105	1-108-700-11	MYLAR	0.047MF	10%	200V
C106	1-108-700-11	MYLAR	0.047MF	10%	200V
C107	1-102-030-00	CERAMIC	330PF	10%	500V
C108	1-136-072-00	FILM	0.0063MF	3%	2KV
C109	1-161-753-00	CERAMIC	470PF	10%	3KV
C110	1-162-114-00	CERAMIC	0.0047MF		2KV
C111	1-136-601-11	FILM	0.01MF	10%	630V
C112	1-136-557-11	FILM	0.0033MF	5%	630V
C113	1-136-173-00	FILM	0.47MF	5%	50V
C116	1-123-330-00	ELECT	22MF	20%	16V
C117	1-123-332-00	ELECT	47MF	20%	16V
C118	1-102-973-00	CERAMIC	100PF	5%	50V
C119	1-108-796-11	MYLAR	0.0022MF	5%	50V
C120	1-123-356-00	ELECT	10MF	20%	16V
C121	1-102-074-00	CERAMIC	0.001MF	10%	50V
C122	1-136-165-00	FILM	0.1MF	5%	50V
C123	1-136-169-00	FILM	0.22MF	5%	50V
C124	1-136-111-00	FILM	1MF	5%	200V
C125	1-136-169-00	FILM	0.22MF	5%	50V
C126	1-102-030-00	CERAMIC	330PF	10%	500V
C127	1-130-736-11	FILM	0.01MF	5%	50V
C128	1-130-994-11	FILM	0.033MF	5%	50V
C129	1-123-369-00	ELECT	4.7MF	20%	25V

Ref.No Part No. Description Remark

C130	1-102-074-00	CERAMIC	0.001MF	10%	50V
C131	1-136-153-00	FILM	0.01MF	5%	50V
C132	1-101-004-00	CERAMIC	0.01MF		50V
C201	1-108-634-11	MYLAR	0.047MF	10%	100V
C202	1-123-356-00	ELECT	10MF	20%	16V

C203	1-101-006-00	CERAMIC	0.047MF		50V
C204	1-124-122-11	ELECT	100MF	20%	16V
C205	1-126-541-11	ELECT	330MF	20%	16V
C207	1-124-122-11	ELECT	100MF	20%	16V
C209	1-101-006-00	CERAMIC	0.047MF		50V

C210	1-123-382-00	ELECT	3.3MF	20%	50V
C211	1-136-157-00	FILM	0.022MF	5%	50V
C212	1-101-006-00	CERAMIC	0.047MF		50V
C213	1-123-356-00	ELECT	10MF	20%	50V
C214	1-123-356-00	ELECT	10MF	20%	50V

C215	Δ 1-123-356-00	ELECT	10MF	20%	16V
C216	Δ 1-102-074-00	CERAMIC	0.001MF	10%	50V
C217	1-123-356-00	ELECT	10MF	20%	16V
C218	1-126-541-11	ELECT	330MF	20%	16V
C219	1-101-004-00	CERAMIC	0.01MF		50V

C220	1-130-994-11	FILM	0.033MF	5%	50V
C221	1-136-163-00	FILM	0.068MF	5%	50V

DIODE

D102	8-719-300-80	DIODE RU-1C
D103	8-719-300-80	DIODE RU-1C
D104	8-719-300-80	DIODE RU-1C
D105	8-719-300-80	DIODE RU-1C
D106	8-719-901-19	DIODE V11N

D107	8-719-109-93	DIODE RD6.2ES-B2
D109	8-719-911-19	DIODE 1SS119
D110	8-719-911-19	DIODE 1SS119
D111	8-719-109-63	DIODE RD3.0ES-B2
D201	8-719-911-19	DIODE 1SS119

D202	8-719-109-72	DIODE RD3.9ES-B2
D203	8-719-911-19	DIODE 1SS119
D204	8-719-000-28	THYRISTOR CR02AM-8
D205	8-719-000-28	THYRISTOR CR02AM-8
D206	8-719-911-19	DIODE 1SS119

D207	8-719-911-19	DIODE 1SS119
D214	8-719-918-50	DIODE HZ12A2LTD
D215	Δ 8-759-157-40	IC UPC574J
D216	Δ 8-759-157-40	IC UPC574J
D217	8-719-911-19	DIODE 1SS119

D218	8-719-911-19	DIODE 1SS119
D219	8-719-911-19	DIODE 1SS119
D220	8-719-911-19	DIODE 1SS119

IC

IC1	8-759-100-75	IC UPC1394C
IC2	8-759-981-64	IC LM2903DQ
IC3	8-759-981-64	IC LM2903DQ
IC4	8-759-990-82	IC TL082CP

COIL

L1	1-459-215-00	COIL (WITH CORE)
----	--------------	------------------

CONNECTOR

PA1	*1-508-765-00	PIN, CONNECTOR (5MM PITCH) 3P
PA2	*1-508-766-00	PIN, CONNECTOR (5MM PITCH) 4P

TRANSISTOR

Q101	8-729-105-97	TRANSISTOR 2SA1156-2K
Q102	8-729-201-62	TRANSISTOR 2SC2555-2
Q103	8-729-202-53	TRANSISTOR 2SD1556-LB

The components identified by shading and mark Δ are critical for safety.
Replace only with part number specified.

The components identified by \square in this manual have been carefully factory-selected for each set in order to satisfy regulations regarding X-ray radiation. Should replacement be required, replace only with the value originally used.

PA PB

Ref.No	Part No.	Description	Remark
Q104	8-729-804-48	TRANSISTOR 2SC3675	
Q105	8-729-804-48	TRANSISTOR 2SC3675	
Q106	8-729-804-48	TRANSISTOR 2SC3675	
Q107	8-729-119-80	TRANSISTOR 2SC2688-LK	
Q108	8-729-119-80	TRANSISTOR 2SC2688-LK	
Q109	8-729-119-76	TRANSISTOR 2SA1175-HFE	
Q110	8-729-119-78	TRANSISTOR 2SC2785-HFE	
Q111	8-729-119-78	TRANSISTOR 2SC2785-HFE	
Q112	8-729-119-78	TRANSISTOR 2SC2785-HFE	
Q201	8-729-119-78	TRANSISTOR 2SC2785-HFE	
Q202	8-729-119-78	TRANSISTOR 2SC2785-HFE	
RESISTOR			
R101	1-216-347-11	METAL OXIDE 0.68	5% 1W F
R102	1-247-887-00	CARBON 220K	5% 1/4W
R103	1-249-419-11	CARBON 1.5K	5% 1/4W
R104	1-216-464-11	METAL OXIDE 18K	5% 2W F
R105	1-216-359-00	METAL OXIDE 6.8	5% 1W F
R106	1-216-351-00	METAL OXIDE 1.5	5% 1W F
R107	1-216-371-00	METAL OXIDE 1.5	5% 2W F
R108	1-212-998-00	FUSIBLE 470	5% 1/2W F
R109	1-215-898-11	METAL OXIDE 10K	5% 2W F
R110	1-202-719-00	SOLID 1M	10% 1/2W
R111	1-202-723-00	SOLID 2.2M	10% 1/2W
R112	1-214-937-00	CARBON 1M	5% 1/2W
R113	1-249-417-11	CARBON 1K	5% 1/4W
R114	1-249-429-11	CARBON 10K	5% 1/4W
R115	1-202-719-00	SOLID 1M	10% 1/2W
R116	1-249-423-11	CARBON 3.3K	5% 1/4W
R117	1-249-429-11	CARBON 10K	5% 1/4W
R118	1-249-429-11	CARBON 10K	5% 1/4W
R119	1-214-937-00	CARBON 1M	5% 1/2W
R120	1-249-433-11	CARBON 22K	5% 1/4W
R121	1-249-435-11	CARBON 33K	5% 1/4W
R122	1-249-435-11	CARBON 33K	5% 1/4W
R123	1-215-454-00	METAL 24K	1% 1/6W
\square R124 Δ		METAL	1/6W
R125	1-215-452-00	METAL 20K	1% 1/6W
\square R126 Δ		METAL	1/6W
R127	1-249-434-11	CARBON 27K	5% 1/4W
R128	1-249-427-11	CARBON 6.8K	5% 1/4W
R129	1-249-440-11	CARBON 82K	5% 1/4W
R130	1-249-425-11	CARBON 4.7K	5% 1/4W
R131	1-249-429-11	CARBON 10K	5% 1/4W
R132	1-249-428-11	CARBON 8.2K	5% 1/4W
R133	1-249-417-11	CARBON 1K	5% 1/4W
R134	1-249-437-11	CARBON 47K	5% 1/4W
R135	1-249-438-11	CARBON 56K	5% 1/4W
R136	1-249-423-11	CARBON 3.3K	5% 1/4W
R137	1-215-461-00	METAL 47K	1% 1/6W
R138	1-215-440-00	METAL 6.2K	1% 1/6W
R139	1-249-424-11	CARBON 3.9K	5% 1/4W
R140	1-249-417-11	CARBON 1K	5% 1/4W
R141	1-249-429-11	CARBON 10K	5% 1/4W
R142	1-249-419-11	CARBON 1.5K	5% 1/4W
R143	1-215-439-00	METAL 5.6K	1% 1/6W
R144	1-215-421-00	METAL 1K	1% 1/6W
R146	1-249-422-11	CARBON 2.7K	5% 1/4W
R148	1-249-422-11	CARBON 2.7K	5% 1/4W
R150	1-249-417-11	CARBON 1K	5% 1/4W
R151	1-249-423-11	CARBON 3.3K	5% 1/4W
R153	1-249-441-11	CARBON 100K	5% 1/4W
R154	1-249-433-11	CARBON 22K	5% 1/4W
R201	1-215-899-11	METAL OXIDE 15K	5% 2W F
R202	1-215-899-11	METAL OXIDE 15K	5% 2W F

Ref.No	Part No.	Description	Remark
R203	1-215-899-11	METAL OXIDE 15K	5% 2W F
R204	1-215-899-11	METAL OXIDE 15K	5% 2W F
R205	1-249-429-11	CARBON 10K	5% 1/4W
R206	1-249-421-11	CARBON 2.2K	5% 1/4W
R207	1-249-393-11	CARBON 10	5% 1/4W
R208	1-249-429-11	CARBON 10K	5% 1/4W
R209	1-249-441-11	CARBON 100K	5% 1/4W
R210	1-249-429-11	CARBON 10K	5% 1/4W
R211	1-249-429-11	CARBON 10K	5% 1/4W
R212	1-249-433-11	CARBON 22K	5% 1/4W
R213	1-249-415-11	CARBON 680	5% 1/4W
R214	1-249-429-11	CARBON 10K	5% 1/4W
R220	1-215-455-00	METAL 27K	1% 1/6W
R221	1-215-437-00	METAL 4.7K	1% 1/6W
\square R222 Δ		METAL	1/6W
R223	1-215-486-00	METAL 510K	1% 1/6W
R224	1-215-471-00	METAL 120K	1% 1/6W
R225	1-215-459-00	METAL 39K	1% 1/6W
R226	1-215-450-00	METAL 16K	1% 1/6W
\square R227 Δ		METAL	1/6W
\square R228 Δ		METAL	1/6W
R229	1-215-469-00	METAL 100K	1% 1/6W
R230	1-215-471-00	METAL 120K	1% 1/6W
R231	1-249-415-11	CARBON 680	5% 1/4W
R232	1-249-429-11	CARBON 10K	5% 1/4W
R237	1-215-455-00	METAL 27K	1% 1/6W
R238	1-215-437-00	METAL 4.7K	1% 1/6W
\square R239 Δ		METAL	1/6W
R240	1-215-486-00	METAL 510K	1% 1/6W
R241	1-215-471-00	METAL 120K	1% 1/6W
R242	1-249-422-11	CARBON 2.7K	5% 1/4W
R243	1-249-422-11	CARBON 2.7K	5% 1/4W
R245	1-247-887-00	CARBON 220K	5% 1/4W
R246	1-249-422-11	CARBON 2.7K	5% 1/4W
R247	1-249-422-11	CARBON 2.7K	5% 1/4W
R248	1-249-399-11	CARBON 33	5% 1/4W
R249	1-249-399-11	CARBON 33	5% 1/4W
R250	1-249-411-11	CARBON 330	5% 1/4W
VARIABLE RESISTOR			
RV1	1-237-500-21	RES, ADJ, CERMET 1K	
TRANSFORMER			
T1	1-437-078-00	TRANSFORMER, HORIZONTAL DRIVE	
T2	1-437-079-00	TRANSFORMER, HORIZONTAL DRIVE	
T3	1-439-384-11	LOT	

*1-617-891-11 PB BOARD *****			
CAPACITOR			
C1	1-130-959-00	FILM 0.047MF	10% 400V
C2	1-130-959-00	FILM 0.047MF	10% 400V
CONNECTOR			
PB1	*1-508-766-00	PIN, CONNECTOR (5MM PITCH) 4P	
RESISTOR			
R1	1-215-429-00	METAL 2.2K	1% 1/6W
R2	1-215-445-00	METAL 10K	1% 1/6W
R3	1-215-429-00	METAL 2.2K	1% 1/6W
R4	1-215-445-00	METAL 10K	1% 1/6W

QA	QB	TA	TB
----	----	----	----

7. ELECTRICAL PARTS LIST

Ref.No	Part No.	Description	Remark
	*1-617-895-11	QA BOARD *****	
<u>CAPACITOR</u>			
C1	1-108-692-11	MYLAR	0.01MF 10% 200V
C2	1-126-235-11	ELECT	100MF 20% 16V
C3	1-101-004-00	CERAMIC	0.01MF 50V
C4	1-108-692-11	MYLAR	0.01MF 10% 200V
C5	1-126-235-11	ELECT	100MF 20% 16V
C6	1-101-004-00	CERAMIC	0.01MF 50V
C7	1-108-692-11	MYLAR	0.01MF 10% 200V
C8	1-126-235-11	ELECT	100MF 20% 16V
C9	1-101-004-00	CERAMIC	0.01MF 50V
C10	1-102-951-00	CERAMIC	15PF 5% 50V
C11	1-102-951-00	CERAMIC	15PF 5% 50V
C12	1-102-951-00	CERAMIC	15PF 5% 50V
<u>RESISTOR</u>			
R1	1-215-449-00	METAL	15K 1% 1/6W
R2	1-215-449-00	METAL	15K 1% 1/6W
R3	1-249-439-11	CARBON	68K 5% 1/4W
<u>SWITCH</u>			
S1	1-570-857-11	SWITCH, SLIDE	
S2	1-570-857-11	SWITCH, SLIDE	
S3	1-570-857-11	SWITCH, SLIDE	

	*1-618-786-11	QB BOARD *****	
<u>CAPACITOR</u>			
C1	1-108-692-11	MYLAR	0.01MF 10% 200V
C2	1-126-235-11	ELECT	100MF 20% 16V
C3	1-101-004-00	CERAMIC	0.01MF 50V
C4	1-108-692-11	MYLAR	0.01MF 10% 200V
C5	1-126-235-11	ELECT	100MF 20% 16V
C6	1-101-004-00	CERAMIC	0.01MF 50V
C7	1-108-692-11	MYLAR	0.01MF 10% 200V
C8	1-126-235-11	ELECT	100MF 20% 16V
C9	1-101-004-00	CERAMIC	0.01MF 50V
C10	1-102-951-00	CERAMIC	15PF 5% 50V
C11	1-102-951-00	CERAMIC	15PF 5% 50V
C12	1-102-951-00	CERAMIC	15PF 5% 50V
<u>RESISTOR</u>			
R1	1-215-449-00	METAL	15K 1% 1/6W
R2	1-215-449-00	METAL	15K 1% 1/6W
R3	1-215-449-00	METAL	15K 1% 1/6W
<u>SWITCH</u>			
S1	1-570-857-11	SWITCH, SLIDE	
S2	1-570-857-11	SWITCH, SLIDE	
S3	1-570-857-11	SWITCH, SLIDE	

	*1-617-898-11	TA BOARD *****	
<u>CONNECTOR</u>			
TA1	*1-566-054-11	PIN, CONNECTOR 2P	
TA2	*1-566-055-11	PIN, CONNECTOR 3P	

Ref.No	Part No.	Description	Remark
TA3	*1-566-056-11	PIN, CONNECTOR 4P	
TA4	*1-566-057-11	PIN, CONNECTOR 5P	
TA5	*1-566-058-11	PIN, CONNECTOR 6P	
TA6	*1-566-055-11	PIN, CONNECTOR 3P	
TA7	*1-566-058-11	PIN, CONNECTOR 6P	
TA8	*1-566-042-11	PIN, CONNECTOR 3P	
TA9	*1-566-045-11	PIN, CONNECTOR 6P	
TA10	*1-566-045-11	PIN, CONNECTOR 6P	
TA11	*1-566-045-11	PIN, CONNECTOR 6P	
TA12	*1-508-786-00	PIN, CONNECTOR (5MM PITCH) 2P	
TA13	*1-561-337-00	CONNECTOR, MULTI	
TA14	*1-561-337-00	CONNECTOR, MULTI	
TA15	*1-561-337-00	CONNECTOR, MULTI	

	*1-617-899-11	TB BOARD *****	
<u>CONNECTOR</u>			
CN1	*1-564-431-11	POST, CONNECTOR 3P	
CN2	*1-564-431-11	POST, CONNECTOR 3P	
CN11	1-561-724-00	SOCKET, CONNECTOR 2P	
CN12	1-561-724-00	SOCKET, CONNECTOR 2P	

Ref.No	Part No.	Description	Remark
R100	1-249-422-11	CARBON	2.7K 5% 1/4W

<u>CONNECTOR</u>			
TB4	*1-566-054-11	PIN, CONNECTOR 2P	
TB5	*1-566-054-11	PIN, CONNECTOR 2P	
TB6	*1-566-060-11	PIN, CONNECTOR 8P	
TB7	*1-566-054-11	PIN, CONNECTOR 2P	
TB8	*1-566-058-11	PIN, CONNECTOR 6P	
TB9	*1-566-060-11	PIN, CONNECTOR 8P	
TB10	*1-566-064-11	PIN, CONNECTOR 12P	
TB11	*1-566-055-11	PIN, CONNECTOR 3P	
TB12	*1-566-064-11	PIN, CONNECTOR 12P	
TB13	*1-566-062-11	PIN, CONNECTOR 10P	
TB14	*1-566-064-11	PIN, CONNECTOR 12P	
TB15	*1-566-060-11	PIN, CONNECTOR 8P	
TB16	*1-566-057-11	PIN, CONNECTOR 5P	
TB17	*1-566-057-11	PIN, CONNECTOR 5P	
TB18	*1-566-055-11	PIN, CONNECTOR 3P	
TB19	*1-566-056-11	PIN, CONNECTOR 4P	
TB20	*1-566-056-11	PIN, CONNECTOR 4P	
TB21	*1-566-056-11	PIN, CONNECTOR 4P	
TB22	*1-566-054-11	PIN, CONNECTOR 2P	
TB23	*1-566-054-11	PIN, CONNECTOR 2P	
TB24	*1-566-054-11	PIN, CONNECTOR 2P	
TB28	*1-566-062-11	PIN, CONNECTOR 10P	
TB31	*1-561-337-00	CONNECTOR, MULTI	
TB32	*1-561-337-00	CONNECTOR, MULTI	
TB33	*1-561-337-00	CONNECTOR, MULTI	
TB34	*1-561-337-00	CONNECTOR, MULTI	
TB35	*1-561-337-00	CONNECTOR, MULTI	
TB36	*1-561-337-00	CONNECTOR, MULTI	
TB37	*1-561-337-00	CONNECTOR, MULTI	
TB38	*1-561-337-00	CONNECTOR, MULTI	
TB39	*1-561-337-00	CONNECTOR, MULTI	
TB40	*1-561-337-00	CONNECTOR, MULTI	

The components identified by shading and mark Δ are critical for safety.
 Replace only with part number specified.



Ref.No Part No. Description Remark

*1-617-896-11 V BOARD

1-563-265-11 CONNECTOR, MULTIPLE 10P

RESISTOR

R1	1-249-405-11	CARBON	100	5%	1/4W
R2	1-249-405-11	CARBON	100	5%	1/4W
R3	1-249-405-11	CARBON	100	5%	1/4W
R4	1-249-405-11	CARBON	100	5%	1/4W
R5	1-249-405-11	CARBON	100	5%	1/4W
R6	1-249-405-11	CARBON	100	5%	1/4W
R7	1-249-405-11	CARBON	100	5%	1/4W

*1-617-897-11 W BOARD

CAPACITOR

C1	1-108-692-11	MYLAR	0.01MF	10%	200V
C2	1-108-692-11	MYLAR	0.01MF	10%	200V
C3	1-108-692-11	MYLAR	0.01MF	10%	200V

RESISTOR

R1	1-214-702-00	METAL	75	1%	1/4W
R2	1-214-702-00	METAL	75	1%	1/4W
R3	1-214-702-00	METAL	75	1%	1/4W

*1-617-892-11 X BOARD

DIODE

D1 8-719-920-21 DIODE LT-9220H

*1-617-893-11 Y BOARD

DIODE

D1 8-719-812-43 DIODE TLG124A

Ref.No Part No. Description Remark

MISCELLANEOUS

Δ 1-162-142-21 CAP BLOCK, HIGH VOLTAGE
 1-216-370-11 RES, METAL OXIDE FILM 12
 1-216-372-11 RES, METAL OXIDE FILM 18
 Δ 1-237-165-12 RESISTOR ASSY, HIGH-VOLTAGE
 Δ 1-426-263-11 COIL, DEMAGNETIZATION

Δ 1-451-287-21 DEFLECTION YOKE (Y14FAA)
 1-452-032-00 MAGNET, DISC ; 10MM ϕ
 1-452-094-00 MAGNET, ROTATABLE DISK ; 15MM ϕ
 Δ 1-452-117-31 CRT NECK ASSY
 Δ 1-452-261-22 CRT NECK ASSY (362)

Δ 1-453-103-41 HIGH-VOLTAGE BLOCK (HB-203 (C))
 Δ 1-532-203-11 FUSE, TIME-LAG 2A/250V (BVM-1410P ONLY)
 Δ 1-532-746-11 FUSE, GLASS TUBE 4A/125V (BVM-1410PM ONLY)
 Δ 1-565-791-11 CONNECTOR, BNC 1P
 S901 Δ 1-570-052-12 SWITCH, PUSH (AC POWER) (1 KEY)

T1 Δ 1-439-382-21 TRANSFORMER ASSY, FLYBACK
 V901 Δ 8-738-052-05 PICTURE TUBE (M34JNR21X)

ACCESSORIS & PACKING MATERIALS

Δ 1-532-203-11 FUSE, TIME-LAG 2A/250V
 Δ 1-532-746-11 FUSE, GLASS TUBE 4A/125V
 Δ 1-590-150-11 POWER CORD (BVM-1410P ONLY)
 Δ 1-551-812-11 POWER CORD (BVM-1410PM ONLY)
 1-560-776-00 SOCKET, CONNECTOR 10P

2-990-242-01 HOLDER (B), PLUG
 4-312-246-00 BAG, PROTECTION
 4-378-901-01 KEY
 4-379-427-01 PLATE, NUMBER, TALLY
 *4-379-479-01 CUSHION (UPPER)

*4-379-480-01 CUSHION (LOWER)
 *4-379-482-01 SPACER
 4-379-487-11 MANUAL, OPERATION & MAINTENANCE
 *4-379-490-01 INDIVIDUAL CARTON (BVM-1410P ONLY)
 *4-379-495-01 INDIVIDUAL CARTON (BVM-1410PM ONLY)

7-700-731-03 DRIVER, VR ADJUSTMENT
 *A-1394-088-A Z BOARD, COMPLETE
 1-561-337-21 CONNECTOR, MULTI
 7-682-547-09 SCREW BVTT 3X6 (S)